

DG105-5.0
DG105-7.5

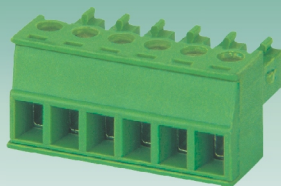

15EDGK-3.5
15EDGK-3.81



15EDGKA-3.5
15EDGKA-3.81

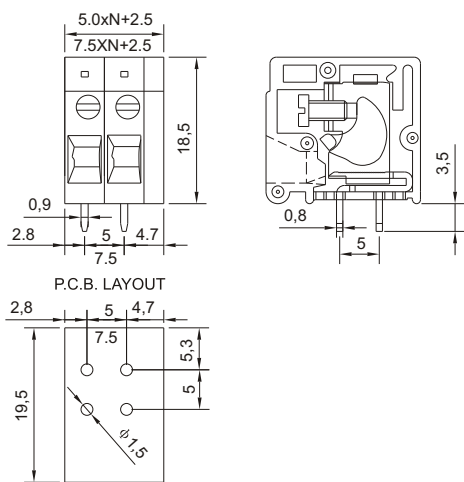

Pitch:5.0mm,7.5mm

● **材质及电镀**

螺丝 : M2.5, 钢, 镀锌
触点材料: 黄铜
焊针 : 黄铜, 镀锡
塑件 : PA66, UL94V-0

● **电气性能**

额定电压 : 300V
额定电流 : 20A
接触电阻 : 20mΩ
绝缘电阻 : 5000MΩ/1000V
耐电压 : AC2000V/1Min
使用线径 : 22-12AWG 2.5mm²

● **机械性能**

温度范围 : -40°C~+105°C
瞬时温度 : +250°C 5秒
扭矩 : 0.4Nm(3.6lb.in)
剥线长度 : 10-11mm

● **Material**

Screws : M2.5 steel Zinc plated
Contact : Brass
Pin header : Brass, Tin plated
Housing : PA66, UL94V-0

● **Electrical**

Rated voltage : 300V
Rated current : 20A
Contact resistance : 20mΩ
Insulation resistance: 5000MΩ/1000V
Withstanding voltage: AC2000V/Min
Wire range : 22-12AWG 2.5mm²

● **Mechanical**

Temp.Range : -40°C~+105°C
MAX Soldering: +250°C, for 5 Sec.
Torque : 0.4Nm(3.6lb.in)
Strip length : 10-11mm

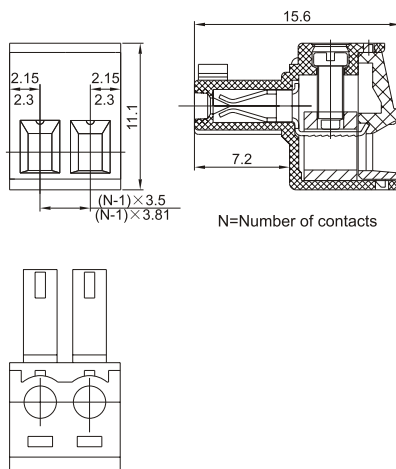

Pitch:3.5mm,3.81mm

● **材质及电镀**

螺丝 : M2, 钢, 镀锌
触点材料: 磷青铜
塑件 : PA66, UL94V-0

● **电气性能**

额定电压 : 300V
额定电流 : 8A
接触电阻 : 20mΩ
绝缘电阻 : 5000MΩ/1000V
耐电压 : AC1500V/1Min
使用线径 : 22-16AWG 1.5mm²

● **机械性能**

温度范围 : -40°C~+130°C
瞬时温度 : +250°C 5秒
扭矩 : 0.2Nm(1.7lb.in)
剥线长度 : 6-7mm

● **Material**

Screws : M2 steel Zinc plated
Contact : Phosphor Bronze
Housing : PA66, UL94V-0

● **Electrical**

Rated voltage : 300V
Rated current : 8A
Contact resistance : 20mΩ
Insulation resistance: 5000MΩ/1000V
Withstanding voltage: AC1500V/1Min
Wire range : 22-16AWG 1.5mm²

● **Mechanical**

Temp.Range : -40°C~+130°C
MAX Soldering: +250°C, for 5 Sec.
Torque : 0.2Nm(1.7lb.in)
Strip length : 6-7mm

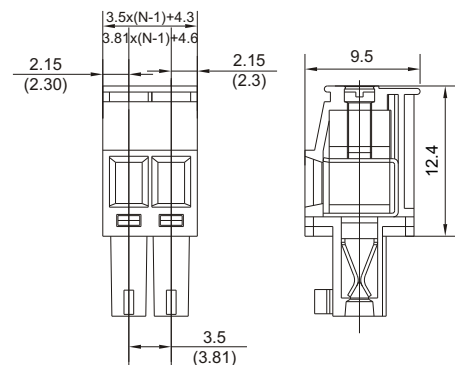

Pitch:3.5mm,3.81mm

● **材质及电镀**

螺丝 : M2, 钢, 镀锌
触点材料: 磷青铜
塑件 : PA66, UL94V-0

● **电气性能**

额定电压 : 300V
额定电流 : 8A
接触电阻 : 20mΩ
绝缘电阻 : 5000MΩ/1000V
耐电压 : AC1500V/1Min
使用线径 : 22-16AWG 1.5mm²

● **机械性能**

温度范围 : -40°C~+130°C
瞬时温度 : +250°C 5秒
扭矩 : 0.2Nm(1.7lb.in)
剥线长度 : 6-7mm

● **Material**

Screws : M2 steel Zinc plated
Contact : Phosphor Bronze
Housing : PA66, UL94V-0

● **Electrical**

Rated voltage : 300V
Rated current : 8A
Contact resistance : 20mΩ
Insulation resistance: 5000MΩ/1000V
Withstanding voltage: AC1500V/1Min
Wire range : 22-16AWG 1.5mm²

● **Mechanical**

Temp.Range : -40°C~+130°C
MAX Soldering: +250°C, for 5 Sec.
Torque : 0.2Nm(1.7lb.in)
Strip length : 6-7mm