

**15EDGKB-3.5**  
**15EDGKB-3.81**

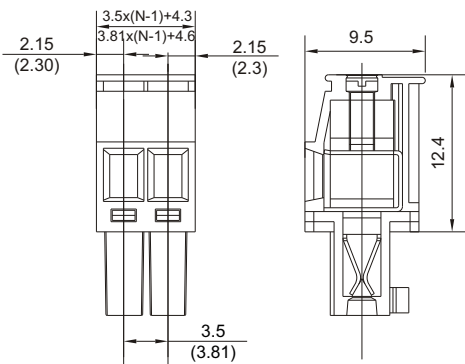

Pitch: 3.5mm, 3.81mm

- **材质及电镀**  
螺丝 : M2, 钢, 镀锌  
触点材料: 磷青铜  
塑件 : PA66, UL94V-0
- **电气性能**  
额定电压 : 300V  
额定电流 : 8A  
接触电阻 : 20mΩ  
绝缘电阻 : 5000MΩ/1000V  
耐电压 : AC1500V/1Min  
使用线径 : 22-16AWG 1.5mm<sup>2</sup>
- **机械性能**  
温度范围 : -40°C~+130°C  
瞬时温度 : +250°C 5秒  
扭矩 : 0.2Nm (1.71b. in)  
剥线长度 : 6-7mm
- **Material**  
Screws : M2 steel Zinc plated  
Contact : Phospor Bronze  
Housing : PA66, UL94V-0
- **Electrical**  
Rated voltage : 300V  
Rated current : 8A  
Contact resistance : 20mΩ  
Insulation resistance: 5000MΩ/1000V  
Withstanding voltage: AC1500V/1Min  
Wire range : 22-16AWG 1.5mm<sup>2</sup>
- **Mechanical**  
Temp. Range : -40°C~+130°C  
MAX Soldering: +250°C, for 5 Sec.  
Torque : 0.2Nm (1.71b. in)  
Strip length : 6-7mm

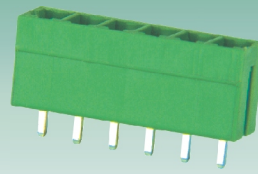

**15EDGV-3.5**  
**15EDGV-3.81**

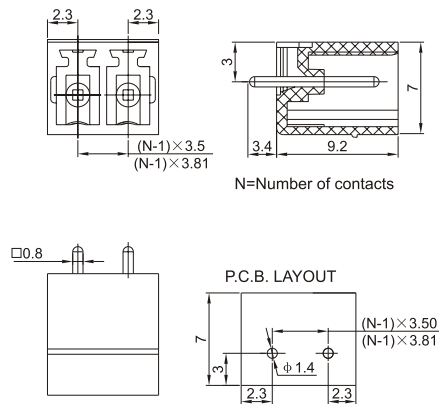

Pitch: 3.5mm, 3.81mm

- **材质及电镀**  
焊针 : 黄铜, 镀锡  
塑件 : PA66, UL94V-0
- **电气性能**  
额定电压 : 300V  
额定电流 : 8A  
接触电阻 : 20mΩ  
绝缘电阻 : 5000MΩ/1000V  
耐电压 : AC1500V/1Min
- **机械性能**  
温度范围 : -40°C~+130°C  
瞬时温度 : +250°C 5秒
- **Material**  
Pin header : Brass, Tin plated  
Housing : PA66, UL94V-0
- **Electrical**  
Rated voltage : 300V  
Rated current : 8A  
Contact resistance : 20mΩ  
Insulation resistance: 5000MΩ/1000V  
Withstanding voltage: AC1500V/1Min
- **Mechanical**  
Temp. Range : -40°C~+130°C  
MAX Soldering: +250°C, for 5 Sec.

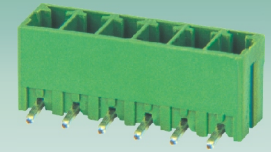

**15EDGR-3.5**  
**15EDGR-3.81**

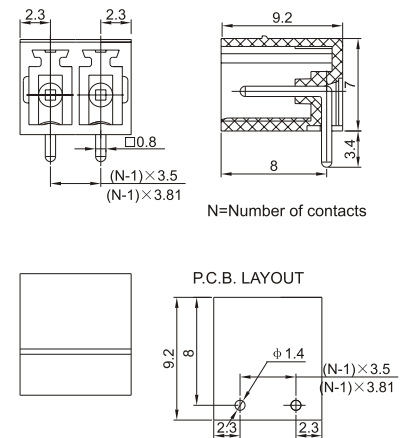

Pitch: 3.5mm, 3.81mm

- **材质及电镀**  
焊针 : 黄铜, 镀锡  
塑件 : PA66, UL94V-0
- **电气性能**  
额定电压 : 300V  
额定电流 : 8A  
接触电阻 : 20mΩ  
绝缘电阻 : 5000MΩ/1000V  
耐电压 : AC1500V/1Min
- **机械性能**  
温度范围 : -40°C~+130°C  
瞬时温度 : +250°C 5秒
- **Material**  
Pin header : Brass, Tin plated  
Housing : PA66, UL94V-0
- **Electrical**  
Rated voltage : 300V  
Rated current : 8A  
Contact resistance : 20mΩ  
Insulation resistance: 5000MΩ/1000V  
Withstanding voltage: AC1500V/1Min
- **Mechanical**  
Temp. Range : -40°C~+130°C  
MAX Soldering: +250°C, for 5 Sec.