

Features

- High-performance, Low-power Atmel®AVR®8-bit Microcontroller
- Advanced RISC Architecture
 - 133 Powerful Instructions – Most Single Clock Cycle Execution
 - 32 x 8 General Purpose Working Registers + Peripheral Control Registers
 - Fully Static Operation
 - Up to 16MIPS Throughput at 16MHz
 - On-chip 2-cycle Multiplier
- High Endurance Non-volatile Memory segments
 - 128Kbytes of In-System Self-programmable Flash program memory
 - 4Kbytes EEPROM
 - 4Kbytes Internal SRAM
 - Write/Erase cycles: 10,000 Flash/100,000 EEPROM
 - Data retention: 20 years at 85°C/100 years at 25°C⁽¹⁾
 - Optional Boot Code Section with Independent Lock Bits
 - In-System Programming by On-chip Boot Program
 - True Read-While-Write Operation
 - Up to 64Kbytes Optional External Memory Space
 - Programming Lock for Software Security
 - SPI Interface for In-System Programming
- QTouch® library support
 - Capacitive touch buttons, sliders and wheels
 - QTouch and QMatrix acquisition
 - Up to 64 sense channels
- JTAG (IEEE std. 1149.1 Compliant) Interface
 - Boundary-scan Capabilities According to the JTAG Standard
 - Extensive On-chip Debug Support
 - Programming of Flash, EEPROM, Fuses and Lock Bits through the JTAG Interface
- Peripheral Features
 - Two 8-bit Timer/Counters with Separate Prescalers and Compare Modes
 - Two Expanded 16-bit Timer/Counters with Separate Prescaler, Compare Mode and Capture Mode
 - Real Time Counter with Separate Oscillator
 - Two 8-bit PWM Channels
 - 6 PWM Channels with Programmable Resolution from 2 to 16 Bits
 - Output Compare Modulator
 - 8-channel, 10-bit ADC
 - 8 Single-ended Channels
 - 7 Differential Channels
 - 2 Differential Channels with Programmable Gain at 1x, 10x, or 200x
 - Byte-oriented Two-wire Serial Interface
 - Dual Programmable Serial USARTs
 - Master/Slave SPI Serial Interface
 - Programmable Watchdog Timer with On-chip Oscillator
 - On-chip Analog Comparator
- Special Microcontroller Features
 - Power-on Reset and Programmable Brown-out Detection
 - Internal Calibrated RC Oscillator
 - External and Internal Interrupt Sources
 - Six Sleep Modes: Idle, ADC Noise Reduction, Power-save, Power-down, Standby, and Extended Standby
 - Software Selectable Clock Frequency
 - ATmega103 Compatibility Mode Selected by a Fuse
 - Global Pull-up Disable
- I/O and Packages
 - 53 Programmable I/O Lines
 - 64-lead TQFP and 64-pad QFN/MLF
- Operating Voltages
 - 2.7 - 5.5V ATmega128L
 - 4.5 - 5.5V ATmega128
- Speed Grades
 - 0 - 8MHz ATmega128L
 - 0 - 16MHz ATmega128



8-bit Atmel Microcontroller with 128KBytes In-System Programmable Flash

ATmega128
ATmega128L

Rev. 2467X-AVR-06/11



Pin Configurations

Figure 1. Pinout ATmega128



Note: The Pinout figure applies to both TQFP and MLF packages. The bottom pad under the QFN/MLF package should be soldered to ground.

Overview

The Atmel® AVR® ATmega128 is a low-power CMOS 8-bit microcontroller based on the AVR enhanced RISC architecture. By executing powerful instructions in a single clock cycle, the ATmega128 achieves throughputs approaching 1MIPS per MHz allowing the system designer to optimize power consumption versus processing speed.

Block Diagram

Figure 2. Block Diagram



The Atmel® AVR® core combines a rich instruction set with 32 general purpose working registers. All the 32 registers are directly connected to the Arithmetic Logic Unit (ALU), allowing two independent registers to be accessed in one single instruction executed in one clock cycle. The resulting architecture is more code efficient while achieving throughputs up to ten times faster than conventional CISC microcontrollers.

The ATmega128 provides the following features: 128Kbytes of In-System Programmable Flash with Read-While-Write capabilities, 4Kbytes EEPROM, 4Kbytes SRAM, 53 general purpose I/O lines, 32 general purpose working registers, Real Time Counter (RTC), four flexible Timer/Counters with compare modes and PWM, 2 USARTs, a byte oriented Two-wire Serial Interface, an 8-channel, 10-bit ADC with optional differential input stage with programmable gain, programmable Watchdog Timer with Internal Oscillator, an SPI serial port, IEEE std. 1149.1 compliant JTAG test interface, also used for accessing the On-chip Debug system and programming and six software selectable power saving modes. The Idle mode stops the CPU while allowing the SRAM, Timer/Counters, SPI port, and interrupt system to continue functioning. The Power-down mode saves the register contents but freezes the Oscillator, disabling all other chip functions until the next interrupt or Hardware Reset. In Power-save mode, the asynchronous timer continues to run, allowing the user to maintain a timer base while the rest of the device is sleeping. The ADC Noise Reduction mode stops the CPU and all I/O modules except Asynchronous Timer and ADC, to minimize switching noise during ADC conversions. In Standby mode, the Crystal/Resonator Oscillator is running while the rest of the device is sleeping. This allows very fast start-up combined with low power consumption. In Extended Standby mode, both the main Oscillator and the Asynchronous Timer continue to run.

Atmel offers the QTouch® library for embedding capacitive touch buttons, sliders and wheels functionality into AVR microcontrollers. The patented charge-transfer signal acquisition offers robust sensing and includes fully debounced reporting of touch keys and includes Adjacent Key Suppression® (AKS™) technology for unambiguous detection of key events. The easy-to-use QTouch Suite toolchain allows you to explore, develop and debug your own touch applications.

The device is manufactured using Atmel's high-density nonvolatile memory technology. The On-chip ISP Flash allows the program memory to be reprogrammed in-system through an SPI serial interface, by a conventional nonvolatile memory programmer, or by an On-chip Boot program running on the AVR core. The boot program can use any interface to download the application program in the application Flash memory. Software in the Boot Flash section will continue to run while the Application Flash section is updated, providing true Read-While-Write operation. By combining an 8-bit RISC CPU with In-System Self-Programmable Flash on a monolithic chip, the Atmel ATmega128 is a powerful microcontroller that provides a highly flexible and cost effective solution to many embedded control applications.

The ATmega128 device is supported with a full suite of program and system development tools including: C compilers, macro assemblers, program debugger/simulators, in-circuit emulators, and evaluation kits.

ATmega103 and ATmega128 Compatibility

The ATmega128 is a highly complex microcontroller where the number of I/O locations supersedes the 64 I/O locations reserved in the AVR instruction set. To ensure backward compatibility with the ATmega103, all I/O locations present in ATmega103 have the same location in ATmega128. Most additional I/O locations are added in an Extended I/O space starting from \$60 to \$FF, (i.e., in the ATmega103 internal RAM space). These locations can be reached by using LD/LDS/LDD and ST/STS/STD instructions only, not by using IN and OUT instructions. The relocation of the internal RAM space may still be a problem for ATmega103 users. Also, the increased number of interrupt vectors might be a problem if the code uses absolute addresses. To solve these problems, an ATmega103 compatibility mode can be selected by programming the fuse M103C. In this mode, none of the functions in the Extended I/O space are in use, so the internal RAM is located as in ATmega103. Also, the Extended Interrupt vectors are removed.



The ATmega128 is 100% pin compatible with ATmega103, and can replace the ATmega103 on current Printed Circuit Boards. The application note “Replacing ATmega103 by ATmega128” describes what the user should be aware of replacing the ATmega103 by an ATmega128.

ATmega103 Compatibility Mode

By programming the M103C fuse, the Atmel®ATmega128 will be compatible with the ATmega103 regards to RAM, I/O pins and interrupt vectors as described above. However, some new features in ATmega128 are not available in this compatibility mode, these features are listed below:

- One USART instead of two, Asynchronous mode only. Only the eight least significant bits of the Baud Rate Register is available.
- One 16 bits Timer/Counter with two compare registers instead of two 16-bit Timer/Counters with three compare registers.
- Two-wire serial interface is not supported.
- Port C is output only.
- Port G serves alternate functions only (not a general I/O port).
- Port F serves as digital input only in addition to analog input to the ADC.
- Boot Loader capabilities is not supported.
- It is not possible to adjust the frequency of the internal calibrated RC Oscillator.
- The External Memory Interface can not release any Address pins for general I/O, neither configure different wait-states to different External Memory Address sections.

In addition, there are some other minor differences to make it more compatible to ATmega103:

- Only EXTRF and PORF exists in MCUCSR.
- Timed sequence not required for Watchdog Time-out change.
- External Interrupt pins 3 - 0 serve as level interrupt only.
- USART has no FIFO buffer, so data overrun comes earlier.

Unused I/O bits in ATmega103 should be written to 0 to ensure same operation in ATmega128.

Pin Descriptions

VCC Digital supply voltage.

GND Ground.

Port A (PA7..PA0) Port A is an 8-bit bi-directional I/O port with internal pull-up resistors (selected for each bit). The Port A output buffers have symmetrical drive characteristics with both high sink and source capability. As inputs, Port A pins that are externally pulled low will source current if the pull-up resistors are activated. The Port A pins are tri-stated when a reset condition becomes active, even if the clock is not running.

Port A also serves the functions of various special features of the ATmega128 as listed on [page 72](#).

Port B (PB7..PB0) Port B is an 8-bit bi-directional I/O port with internal pull-up resistors (selected for each bit). The Port B output buffers have symmetrical drive characteristics with both high sink and source capability. As inputs, Port B pins that are externally pulled low will source current if the pull-up resistors are activated. The Port B pins are tri-stated when a reset condition becomes active, even if the clock is not running.

Port B also serves the functions of various special features of the ATmega128 as listed on [page 73](#).



Port C (PC7..PC0)

Port C is an 8-bit bi-directional I/O port with internal pull-up resistors (selected for each bit). The Port C output buffers have symmetrical drive characteristics with both high sink and source capability. As inputs, Port C pins that are externally pulled low will source current if the pull-up resistors are activated. The Port C pins are tri-stated when a reset condition becomes active, even if the clock is not running.

Port C also serves the functions of special features of the Atmel® AVR®ATmega128 as listed on [page 76](#). In ATmega103 compatibility mode, Port C is output only, and the port C pins are not tri-stated when a reset condition becomes active.

Note: The ATmega128 is by default shipped in ATmega103 compatibility mode. Thus, if the parts are not programmed before they are put on the PCB, PORTC will be output during first power up, and until the ATmega103 compatibility mode is disabled.

Port D (PD7..PD0)

Port D is an 8-bit bi-directional I/O port with internal pull-up resistors (selected for each bit). The Port D output buffers have symmetrical drive characteristics with both high sink and source capability. As inputs, Port D pins that are externally pulled low will source current if the pull-up resistors are activated. The Port D pins are tri-stated when a reset condition becomes active, even if the clock is not running.

Port D also serves the functions of various special features of the ATmega128 as listed on [page 77](#).

Port E (PE7..PE0)

Port E is an 8-bit bi-directional I/O port with internal pull-up resistors (selected for each bit). The Port E output buffers have symmetrical drive characteristics with both high sink and source capability. As inputs, Port E pins that are externally pulled low will source current if the pull-up resistors are activated. The Port E pins are tri-stated when a reset condition becomes active, even if the clock is not running.

Port E also serves the functions of various special features of the ATmega128 as listed on [page 80](#).

Port F (PF7..PF0)

Port F serves as the analog inputs to the A/D Converter.

Port F also serves as an 8-bit bi-directional I/O port, if the A/D Converter is not used. Port pins can provide internal pull-up resistors (selected for each bit). The Port F output buffers have symmetrical drive characteristics with both high sink and source capability. As inputs, Port F pins that are externally pulled low will source current if the pull-up resistors are activated. The Port F pins are tri-stated when a reset condition becomes active, even if the clock is not running. If the JTAG interface is enabled, the pull-up resistors on pins PF7(TDI), PF5(TMS), and PF4(TCK) will be activated even if a Reset occurs.

The TDO pin is tri-stated unless TAP states that shift out data are entered.

Port F also serves the functions of the JTAG interface.

In ATmega103 compatibility mode, Port F is an input Port only.

Port G (PG4..PG0)

Port G is a 5-bit bi-directional I/O port with internal pull-up resistors (selected for each bit). The Port G output buffers have symmetrical drive characteristics with both high sink and source capability. As inputs, Port G pins that are externally pulled low will source current if the pull-up resistors are activated. The Port G pins are tri-stated when a reset condition becomes active, even if the clock is not running.

Port G also serves the functions of various special features.

The port G pins are tri-stated when a reset condition becomes active, even if the clock is not running.

In ATmega103 compatibility mode, these pins only serves as strobes signals to the external memory as well as input to the 32kHz Oscillator, and the pins are initialized to PG0 = 1, PG1 = 1, and PG2 = 0 asynchronously when a reset condition becomes active, even if the clock is not running. PG3 and PG4 are oscillator pins.

RESET

Reset input. A low level on this pin for longer than the minimum pulse length will generate a reset, even if the clock is not running. The minimum pulse length is given in [Table 19 on page 50](#). Shorter pulses are not guaranteed to generate a reset.

XTAL1

Input to the inverting Oscillator amplifier and input to the internal clock operating circuit.

XTAL2

Output from the inverting Oscillator amplifier.

AVCC

AVCC is the supply voltage pin for Port F and the A/D Converter. It should be externally connected to V_{CC} , even if the ADC is not used. If the ADC is used, it should be connected to V_{CC} through a low-pass filter.

AREF

AREF is the analog reference pin for the A/D Converter.

PEN

PEN is a programming enable pin for the SPI Serial Programming mode, and is internally pulled high. By holding this pin low during a Power-on Reset, the device will enter the SPI Serial Programming mode. PEN has no function during normal operation.

Resources

A comprehensive set of development tools, application notes, and datasheets are available for download on <http://www.atmel.com/avr>.

Data Retention

Reliability Qualification results show that the projected data retention failure rate is much less than 1 PPM over 20 years at 85°C or 100 years at 25°C

About Code Examples

This datasheet contains simple code examples that briefly show how to use various parts of the device. These code examples assume that the part specific header file is included before compilation. Be aware that not all C compiler vendors include bit definitions in the header files and interrupt handling in C is compiler dependent. Please confirm with the C compiler documentation for more details.

For I/O registers located in extended I/O map, “IN”, “OUT”, “SBIS”, “SBIC”, “CBI”, and “SBI” instructions must be replaced with instructions that allow access to extended I/O. Typically “LDS” and “STS” combined with “SBRS”, “SBRC”, “SBR”, and “CBR”.

Capacitive touch sensing

The Atmel QTouch Library provides a simple to use solution to realize touch sensitive interfaces on most Atmel AVR microcontrollers. The QTouch Library includes support for the QTouch and QMatrix acquisition methods.

Touch sensing can be added to any application by linking the appropriate Atmel QTouch Library for the AVR Microcontroller. This is done by using a simple set of APIs to define the touch channels and sensors, and then calling the touch sensing API's to retrieve the channel information and determine the touch sensor states.

The QTouch Library is FREE and downloadable from the Atmel website at the following location: www.atmel.com/qtouchlibrary. For implementation details and other information, refer to the [Atmel QTouch Library User Guide](#) - also available for download from the Atmel website.

AVR CPU Core

Introduction

This section discusses the Atmel® AVR® core architecture in general. The main function of the CPU core is to ensure correct program execution. The CPU must therefore be able to access memories, perform calculations, control peripherals and handle interrupts.

Architectural Overview

Figure 3. Block Diagram of the AVR Architecture



In order to maximize performance and parallelism, the AVR uses a Harvard architecture – with separate memories and buses for program and data. Instructions in the program memory are executed with a single level pipelining. While one instruction is being executed, the next instruction is pre-fetched from the program memory. This concept enables instructions to be executed in every clock cycle. The program memory is In-System Reprogrammable Flash memory.

The fast-access Register file contains 32 x 8-bit general purpose working registers with a single clock cycle access time. This allows single-cycle Arithmetic Logic Unit (ALU) operation. In a typical ALU operation, two operands are output from the Register file, the operation is executed, and the result is stored back in the Register file – in one clock cycle.

Six of the 32 registers can be used as three 16-bit indirect address register pointers for Data Space addressing – enabling efficient address calculations. One of these address pointers can also be used as an address pointer for look up tables in Flash Program memory. These added function registers are the 16-bit X-register, Y-register and Z-register, described later in this section.

The ALU supports arithmetic and logic operations between registers or between a constant and a register. Single register operations can also be executed in the ALU. After an arithmetic operation, the Status Register is updated to reflect information about the result of the operation.

Program flow is provided by conditional and unconditional jump and call instructions, able to directly address the whole address space. Most AVR instructions have a single 16-bit word format. Every program memory address contains a 16-bit or 32-bit instruction.

Program Flash memory space is divided in two sections, the Boot Program section and the Application Program section. Both sections have dedicated Lock bits for write and read/write protection. The SPM instruction that writes into the Application Flash Memory section must reside in the Boot Program section.

During interrupts and subroutine calls, the return address Program Counter (PC) is stored on the Stack. The Stack is effectively allocated in the general data SRAM, and consequently the stack size is only limited by the total SRAM size and the usage of the SRAM. All user programs must initialize the SP in the reset routine (before subroutines or interrupts are executed). The Stack Pointer – SP – is read/write accessible in the I/O space. The data SRAM can easily be accessed through the five different addressing modes supported in the AVR architecture.

The memory spaces in the AVR architecture are all linear and regular memory maps.

A flexible interrupt module has its control registers in the I/O space with an additional global interrupt enable bit in the Status Register. All interrupts have a separate interrupt vector in the interrupt vector table. The interrupts have priority in accordance with their interrupt vector position. The lower the interrupt vector address, the higher the priority.

The I/O memory space contains 64 addresses which can be accessed directly, or as the Data Space locations following those of the Register file, \$20 - \$5F. In addition, the ATmega128 has Extended I/O space from \$60 - \$FF in SRAM where only the ST/STS/STD and LD/LDS/LDD instructions can be used.

ALU – Arithmetic Logic Unit

The high-performance AVR ALU operates in direct connection with all the 32 general purpose working registers. Within a single clock cycle, arithmetic operations between general purpose registers or between a register and an immediate are executed. The ALU operations are divided into three main categories – arithmetic, logical, and bit-functions. Some implementations of the architecture also provide a powerful multiplier supporting both signed/unsigned multiplication and fractional format. See the “Instruction Set” section for a detailed description.

Status Register

The Status Register contains information about the result of the most recently executed arithmetic instruction. This information can be used for altering program flow in order to perform conditional operations. Note that the Status Register is updated after all ALU operations, as specified in the Instruction Set Reference. This will in many cases remove the need for using the dedicated compare instructions, resulting in faster and more compact code.

The status register is not automatically stored when entering an interrupt routine and restored when returning from an interrupt. This must be handled by software.

The AVR status Register – SREG – is defined as:

| | | | | | | | | | |
|---------------|-----|-----|-----|-----|-----|-----|-----|-----|------|
| Bit | 7 | 6 | 5 | 4 | 3 | 2 | 1 | 0 | |
| | I | T | H | S | V | N | Z | C | SREG |
| Read/Write | R/W | R/W | R/W | R/W | R/W | R/W | R/W | R/W | |
| Initial Value | 0 | 0 | 0 | 0 | 0 | 0 | 0 | 0 | |

- **Bit 7 – I: Global Interrupt Enable**

The Global Interrupt Enable bit must be set for the interrupts to be enabled. The individual interrupt enable control is then performed in separate control registers. If the Global Interrupt Enable Register is cleared, none of the interrupts are enabled independent of the individual interrupt enable settings. The I-bit is cleared by hardware after an interrupt has occurred, and is set by the RETI instruction to enable subsequent interrupts. The I-bit can also be set and cleared in software with the SEI and CLI instructions, as described in the instruction set reference.

- **Bit 6 – T: Bit Copy Storage**

The Bit Copy instructions BLD (Bit Load) and BST (Bit Store) use the T-bit as source or destination for the operated bit. A bit from a register in the Register file can be copied into T by the BST instruction, and a bit in T can be copied into a bit in a register in the Register file by the BLD instruction.

- **Bit 5 – H: Half Carry Flag**

The Half Carry Flag H indicates a half carry in some arithmetic operations. Half carry is useful in BCD arithmetic. See the “Instruction Set Description” for detailed information.

- **Bit 4 – S: Sign Bit, $S = N \oplus V$**

The S-bit is always an exclusive or between the negative flag N and the two’s complement overflow flag V. See the “Instruction Set Description” for detailed information.

- **Bit 3 – V: Two’s Complement Overflow Flag**

The Two’s Complement Overflow Flag V supports two’s complement arithmetics. See the “Instruction Set Description” for detailed information.

- **Bit 2 – N: Negative Flag**

The Negative Flag N indicates a negative result in an arithmetic or logic operation. See the “Instruction Set Description” for detailed information.

- **Bit 1 – Z: Zero Flag**

The Zero Flag Z indicates a zero result in an arithmetic or logic operation. See the “Instruction Set Description” for detailed information.

- **Bit 0 – C: Carry Flag**

The Carry Flag C indicates a carry in an arithmetic or logic operation. See the “Instruction Set Description” for detailed information.

General Purpose Register File

The Register file is optimized for the AVR Enhanced RISC instruction set. In order to achieve the required performance and flexibility, the following input/output schemes are supported by the Register file:

- One 8-bit output operand and one 8-bit result input
- Two 8-bit output operands and one 8-bit result input
- Two 8-bit output operands and one 16-bit result input
- One 16-bit output operand and one 16-bit result input

Figure 4 on page 12 shows the structure of the 32 general purpose working registers in the CPU.

Figure 4. AVR CPU General Purpose Working Registers

| | 7 | 0 | Addr. | |
|--|-----|---|-------|----------------------|
| General Purpose Working Registers | R0 | | \$00 | |
| | R1 | | \$01 | |
| | R2 | | \$02 | |
| | ... | | | |
| | R13 | | \$0D | |
| | R14 | | \$0E | |
| | R15 | | \$0F | |
| | R16 | | \$10 | |
| | R17 | | \$11 | |
| | ... | | | |
| | R26 | | \$1A | X-register Low Byte |
| | R27 | | \$1B | X-register High Byte |
| | R28 | | \$1C | Y-register Low Byte |
| | R29 | | \$1D | Y-register High Byte |
| | R30 | | \$1E | Z-register Low Byte |
| | R31 | | \$1F | Z-register High Byte |

Most of the instructions operating on the Register file have direct access to all registers, and most of them are single cycle instructions.

As shown in [Figure 4](#), each register is also assigned a data memory address, mapping them directly into the first 32 locations of the user Data Space. Although not being physically implemented as SRAM locations, this memory organization provides great flexibility in access of the registers, as the X-, Y-, and Z-pointer Registers can be set to index any register in the file.

X-register, Y-register, and Z-register

The registers R26..R31 have some added functions to their general purpose usage. These registers are 16-bit address pointers for indirect addressing of the Data Space. The three indirect address registers X, Y, and Z are described in [Figure 5](#).

Figure 5. The X-, Y-, and Z-registers

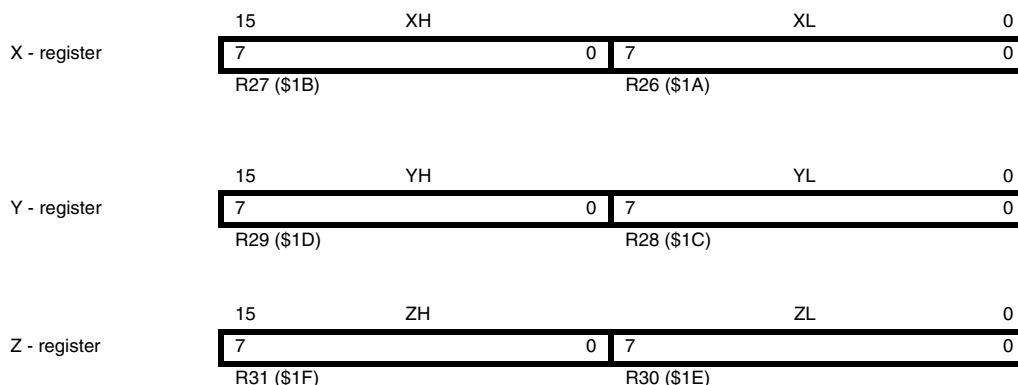

In the different addressing modes these address registers have functions as fixed displacement, automatic increment, and automatic decrement (see the Instruction Set Reference for details).

Stack Pointer

The Stack is mainly used for storing temporary data, for storing local variables and for storing return addresses after interrupts and subroutine calls. The Stack Pointer Register always points to the top of the Stack. Note that the Stack is implemented as growing from higher memory locations to lower memory locations. This implies that a Stack PUSH command decreases the Stack Pointer.

The Stack Pointer points to the data SRAM stack area where the Subroutine and Interrupt Stacks are located. This Stack space in the data SRAM must be defined by the program before any subroutine calls are executed or interrupts are enabled. The Stack Pointer must be set to point above \$60. The Stack Pointer is decremented by one when data is pushed onto the Stack with the PUSH instruction, and it is decremented by two when the return address is pushed onto the Stack with subroutine call or interrupt. The Stack Pointer is incremented by one when data is popped from the Stack with the POP instruction, and it is incremented by two when data is popped from the Stack with return from subroutine RET or return from interrupt RETI.

The AVR Stack Pointer is implemented as two 8-bit registers in the I/O space. The number of bits actually used is implementation dependent. Note that the data space in some implementations of the AVR architecture is so small that only SPL is needed. In this case, the SPH Register will not be present.

| Bit | 15 | 14 | 13 | 12 | 11 | 10 | 9 | 8 | |
|---------------|------|------|------|------|------|------|-----|-----|-----|
| | SP15 | SP14 | SP13 | SP12 | SP11 | SP10 | SP9 | SP8 | SPH |
| | SP7 | SP6 | SP5 | SP4 | SP3 | SP2 | SP1 | SP0 | SPL |
| | 7 | 6 | 5 | 4 | 3 | 2 | 1 | 0 | |
| Read/Write | R/W | R/W | R/W | R/W | R/W | R/W | R/W | R/W | |
| | R/W | R/W | R/W | R/W | R/W | R/W | R/W | R/W | |
| Initial Value | 0 | 0 | 0 | 0 | 0 | 0 | 0 | 0 | |
| | 0 | 0 | 0 | 0 | 0 | 0 | 0 | 0 | |

RAM Page Z Select Register – RAMPZ

| Bit | 7 | 6 | 5 | 4 | 3 | 2 | 1 | 0 | |
|---------------|---|---|---|---|---|---|---|--------|-------|
| | – | – | – | – | – | – | – | RAMPZ0 | RAMPZ |
| Read/Write | R | R | R | R | R | R | R | R/W | |
| Initial Value | 0 | 0 | 0 | 0 | 0 | 0 | 0 | 0 | |

- **Bits 7..1 – Res: Reserved Bits**

These are reserved bits and will always read as zero. When writing to this address location, write these bits to zero for compatibility with future devices.

- **Bit 0 – RAMPZ0: Extended RAM Page Z-pointer**

The RAMPZ Register is normally used to select which 64K RAM Page is accessed by the Z-pointer. As the ATmega128 does not support more than 64K of SRAM memory, this register is used only to select which page in the program memory is accessed when the ELPM/SPM instruction is used. The different settings of the RAMPZ0 bit have the following effects:

RAMPZ0 = 0: Program memory address \$0000 - \$7FFF (lower 64 Kbytes) is accessed by ELPM/SPM

RAMPZ0 = 1: Program memory address \$8000 - \$FFFF (higher 64 Kbytes) is accessed by ELPM/SPM

Note that LPM is not affected by the RAMPZ setting.

Instruction Execution Timing

This section describes the general access timing concepts for instruction execution. The AVR CPU is driven by the CPU clock clk_{CPU} , directly generated from the selected clock source for the chip. No internal clock division is used.

Figure 6 shows the parallel instruction fetches and instruction executions enabled by the Harvard architecture and the fast-access Register file concept. This is the basic pipelining concept to obtain up to 1 MIPS per MHz with the corresponding unique results for functions per cost, functions per clocks, and functions per power-unit.

Figure 6. The Parallel Instruction Fetches and Instruction Executions



Figure 7 shows the internal timing concept for the Register file. In a single clock cycle an ALU operation using two register operands is executed, and the result is stored back to the destination register.

Figure 7. Single Cycle ALU Operation

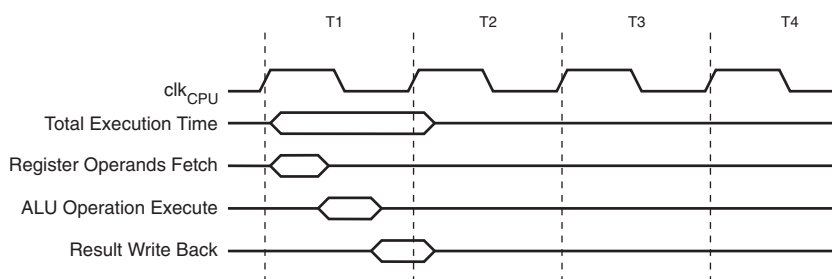

Reset and Interrupt Handling

The AVR provides several different interrupt sources. These interrupts and the separate reset vector each have a separate program vector in the program memory space. All interrupts are assigned individual enable bits which must be written logic one together with the Global Interrupt Enable bit in the Status Register in order to enable the interrupt. Depending on the Program Counter value, interrupts may be automatically disabled when Boot Lock bits BLB02 or BLB12 are programmed. This feature improves software security. See the section “[Memory Programming](#)” on page 286 for details.

The lowest addresses in the program memory space are by default defined as the Reset and Interrupt vectors. The complete list of vectors is shown in “[Interrupts](#)” on page 59. The list also determines the priority levels of the different interrupts. The lower the address the higher is the priority level. RESET has the highest priority, and next is INT0 – the External Interrupt Request 0. The interrupt vectors can be moved to the start of the boot Flash section by setting the IVSEL bit in the MCU Control Register (MCUCR). Refer to “[Interrupts](#)” on page 59 for more information. The Reset vector can also be moved to the start of the boot Flash section by programming the BOOTRST fuse, see “[Boot Loader Support – Read-While-Write Self-Programming](#)” on page 273.

When an interrupt occurs, the Global Interrupt Enable I-bit is cleared and all interrupts are disabled. The user software can write logic one to the I-bit to enable nested interrupts. All enabled interrupts can then interrupt the current interrupt routine. The I-bit is automatically set when a Return from Interrupt instruction – RETI – is executed.

There are basically two types of interrupts. The first type is triggered by an event that sets the interrupt flag. For these interrupts, the Program Counter is vectored to the actual interrupt vector in order to execute the interrupt handling routine, and hardware clears the corresponding interrupt flag. Interrupt flags can also be cleared by writing a logic one to the flag bit position(s) to be cleared. If an interrupt condition occurs while the corresponding interrupt enable bit is cleared, the interrupt flag will be set and remembered until the interrupt is enabled, or the flag is cleared by software. Similarly, if one or more interrupt conditions occur while the global interrupt enable bit is cleared, the corresponding interrupt flag(s) will be set and remembered until the global interrupt enable bit is set, and will then be executed by order of priority.

The second type of interrupts will trigger as long as the interrupt condition is present. These interrupts do not necessarily have interrupt flags. If the interrupt condition disappears before the interrupt is enabled, the interrupt will not be triggered.

When the AVR exits from an interrupt, it will always return to the main program and execute one more instruction before any pending interrupt is served.

Note that the Status Register is not automatically stored when entering an interrupt routine, nor restored when returning from an interrupt routine. This must be handled by software.

When using the CLI instruction to disable interrupts, the interrupts will be immediately disabled. No interrupt will be executed after the CLI instruction, even if it occurs simultaneously with the CLI instruction. The following example shows how this can be used to avoid interrupts during the timed EEPROM write sequence.

Assembly Code Example

```

in r16, SREG      ; store SREG value
cli              ; disable interrupts during timed sequence
sbi EECR, EEMWE  ; start EEPROM write
sbi EECR, EEWE
out SREG, r16    ; restore SREG value (I-bit)
    
```

C Code Example

```

char cSREG;
cSREG = SREG; /* store SREG value */
/* disable interrupts during timed sequence */
__disable_interrupt();
EECR |= (1<<EEMWE); /* start EEPROM write */
EECR |= (1<<EEWE);
SREG = cSREG; /* restore SREG value (I-bit) */
    
```

When using the SEI instruction to enable interrupts, the instruction following SEI will be executed before any pending interrupts, as shown in this example.

| Assembly Code Example |
|---|
| <pre>sei ; set global interrupt enable sleep; enter sleep, waiting for interrupt ; note: will enter sleep before any pending ; interrupt(s)</pre> |
| C Code Example |
| <pre>__enable_interrupt(); /* set global interrupt enable */ __sleep(); /* enter sleep, waiting for interrupt */ /* note: will enter sleep before any pending interrupt(s) */</pre> |

Interrupt Response Time

The interrupt execution response for all the enabled AVR interrupts is four clock cycles minimum. After four clock cycles, the program vector address for the actual interrupt handling routine is executed. During this 4-clock cycle period, the Program Counter is pushed onto the Stack. The vector is normally a jump to the interrupt routine, and this jump takes three clock cycles. If an interrupt occurs during execution of a multi-cycle instruction, this instruction is completed before the interrupt is served. If an interrupt occurs when the MCU is in Sleep mode, the interrupt execution response time is increased by four clock cycles. This increase comes in addition to the start-up time from the selected sleep mode.

A return from an interrupt handling routine takes four clock cycles. During these 4-clock cycles, the Program Counter (two bytes) is popped back from the Stack, the Stack Pointer is incremented by two, and the I-bit in SREG is set.

AVR ATmega128 Memories

This section describes the different memories in the Atmel® AVR® ATmega128. The AVR architecture has two main memory spaces, the Data Memory and the Program Memory space. In addition, the ATmega128 features an EEPROM Memory for data storage. All three memory spaces are linear and regular.

In-System Reprogrammable Flash Program Memory

The ATmega128 contains 128Kbytes On-chip In-System Reprogrammable Flash memory for program storage. Since all AVR instructions are 16 or 32 bits wide, the Flash is organized as 64K x 16. For software security, the Flash Program memory space is divided into two sections, Boot Program section and Application Program section.

The Flash memory has an endurance of at least 10,000 write/erase cycles. The ATmega128 Program Counter (PC) is 16 bits wide, thus addressing the 64K program memory locations. The operation of Boot Program section and associated Boot Lock bits for software protection are described in detail in [“Boot Loader Support – Read-While-Write Self-Programming” on page 273](#). [“Memory Programming” on page 286](#) contains a detailed description on Flash programming in SPI, JTAG, or Parallel Programming mode.

Constant tables can be allocated within the entire program memory address space (see the LPM – Load Program Memory and ELPM – Extended Load Program Memory instruction description).

Timing diagrams for instruction fetch and execution are presented in [“Instruction Execution Timing” on page 13](#).

Figure 8. Program Memory Map



SRAM Data Memory

The Atmel® AVR® ATmega128 supports two different configurations for the SRAM data memory as listed in [Table 1](#).

Table 1. Memory Configurations

| Configuration | Internal SRAM Data Memory | External SRAM Data Memory |
|------------------------------|---------------------------|---------------------------|
| Normal mode | 4096 | up to 64K |
| ATmega103 Compatibility mode | 4000 | up to 64K |

[Figure 9](#) shows how the ATmega128 SRAM Memory is organized.

The ATmega128 is a complex microcontroller with more peripheral units than can be supported within the 64 location reserved in the Opcode for the IN and OUT instructions. For the Extended I/O space from \$60 - \$FF in SRAM, only the ST/STS/STD and LD/LDS/LDD instructions can be used. The Extended I/O space does not exist when the ATmega128 is in the ATmega103 compatibility mode.

In normal mode, the first 4352 Data Memory locations address both the Register file, the I/O Memory, Extended I/O Memory, and the internal data SRAM. The first 32 locations address the Register file, the next 64 location the standard I/O memory, then 160 locations of Extended I/O memory, and the next 4096 locations address the internal data SRAM.

In ATmega103 compatibility mode, the first 4096 Data Memory locations address both the Register file, the I/O Memory and the internal data SRAM. The first 32 locations address the Register file, the next 64 location the standard I/O memory, and the next 4000 locations address the internal data SRAM.

An optional external data SRAM can be used with the ATmega128. This SRAM will occupy an area in the remaining address locations in the 64K address space. This area starts at the address following the internal SRAM. The Register file, I/O, Extended I/O and Internal SRAM occupies the lowest 4352bytes in normal mode, and the lowest 4096bytes in the ATmega103 compatibility mode (Extended I/O not present), so when using 64Kbyte (65536 bytes) of External Memory, 61184bytes of External Memory are available in normal mode, and 61440 bytes in ATmega103 compatibility mode. See [“External Memory Interface” on page 25](#) for details on how to take advantage of the external memory map.

When the addresses accessing the SRAM memory space exceeds the internal data memory locations, the external data SRAM is accessed using the same instructions as for the internal data memory access. When the internal data memories are accessed, the read and write strobe pins (PG0 and PG1) are inactive during the whole access cycle. External SRAM operation is enabled by setting the SRE bit in the MCUCR Register.

Accessing external SRAM takes one additional clock cycle per byte compared to access of the internal SRAM. This means that the commands LD, ST, LDS, STS, LDD, STD, PUSH, and POP take one additional clock cycle. If the Stack is placed in external SRAM, interrupts, subroutine calls and returns take three clock cycles extra because the two-byte program counter is pushed and popped, and external memory access does not take advantage of the internal pipe-line memory access. When external SRAM interface is used with wait-state, one-byte external access takes two, three, or four additional clock cycles for one, two, and three wait-states respectively. Interrupts, subroutine calls and returns will need five, seven, or nine clock cycles more than specified in the instruction set manual for one, two, and three wait-states.

The five different addressing modes for the data memory cover: Direct, Indirect with Displacement, Indirect, Indirect with Pre-decrement, and Indirect with Post-increment. In the Register file, registers R26 to R31 feature the indirect addressing pointer registers.

The direct addressing reaches the entire data space.



The Indirect with Displacement mode reaches 63 address locations from the base address given by the Y- or Z-register.

When using register indirect addressing modes with automatic pre-decrement and post-increment, the address registers X, Y, and Z are decremented or incremented.

The 32 general purpose working registers, 64 I/O registers, and the 4096bytes of internal data SRAM in the ATmega128 are all accessible through all these addressing modes. The Register file is described in [“General Purpose Register File”](#) on page 11.

Figure 9. Data Memory Map



Data Memory Access Times

This section describes the general access timing concepts for internal memory access. The internal data SRAM access is performed in two clk_{CPU} cycles as described in [Figure 10](#).

Figure 10. On-chip Data SRAM Access Cycles

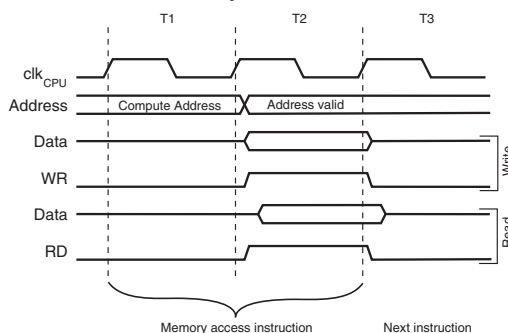

EEPROM Data Memory

The Atmel® AVR® ATmega128 contains 4Kbytes of data EEPROM memory. It is organized as a separate data space, in which single bytes can be read and written. The EEPROM has an endurance of at least 100,000 write/erase cycles. The access between the EEPROM and the CPU is described in the following, specifying the EEPROM Address Registers, the EEPROM Data Register, and the EEPROM Control Register.

[“Memory Programming” on page 286](#) contains a detailed description on EEPROM programming in SPI, JTAG, or Parallel Programming mode

EEPROM Read/Write Access

The EEPROM access registers are accessible in the I/O space.

The write access time for the EEPROM is given in [Table 2](#). A self-timing function, however, lets the user software detect when the next byte can be written. If the user code contains instructions that write the EEPROM, some precautions must be taken. In heavily filtered power supplies, V_{CC} is likely to rise or fall slowly on Power-up/down. This causes the device for some period of time to run at a voltage lower than specified as minimum for the clock frequency used. See [“Preventing EEPROM Corruption” on page 24](#). for details on how to avoid problems in these situations.

In order to prevent unintentional EEPROM writes, a specific write procedure must be followed. Refer to the description of the EEPROM Control Register for details on this.

When the EEPROM is read, the CPU is halted for four clock cycles before the next instruction is executed. When the EEPROM is written, the CPU is halted for two clock cycles before the next instruction is executed.

EEPROM Address Register – EEARH and EEARL

| Bit | 15 | 14 | 13 | 12 | 11 | 10 | 9 | 8 | |
|---------------|-----|-----|-----|-----|--------|--------|-------|-------|-------|
| | - | - | - | - | EEAR11 | EEAR10 | EEAR9 | EEAR8 | EEARH |
| | | | | | EEAR3 | EEAR2 | EEAR1 | EEAR0 | EEARL |
| | 7 | 6 | 5 | 4 | 3 | 2 | 1 | 0 | |
| Read/Write | R | R | R | R | R/W | R/W | R/W | R/W | |
| | R/W | R/W | R/W | R/W | R/W | R/W | R/W | R/W | |
| Initial Value | 0 | 0 | 0 | 0 | X | X | X | X | |
| | X | X | X | X | X | X | X | X | |

- Bits 15..12 – Res: Reserved Bits**

These are reserved bits and will always read as zero. When writing to this address location, write these bits to zero for compatibility with future devices.

- **Bits 11..0 – EEAR11..0: EEPROM Address**

The EEPROM Address Registers – EEARH and EEARL – specify the EEPROM address in the 4 Kbytes EEPROM space. The EEPROM data bytes are addressed linearly between 0 and 4096. The initial value of EEAR is undefined. A proper value must be written before the EEPROM may be accessed.

EEPROM Data Register – EEDR

| | | | | | | | | | |
|---------------|------------|-----|-----|-----|-----|-----|-----|------------|-------------|
| Bit | 7 | 6 | 5 | 4 | 3 | 2 | 1 | 0 | |
| | MSB | | | | | | | LSB | EEDR |
| Read/Write | R/W | R/W | R/W | R/W | R/W | R/W | R/W | R/W | |
| Initial Value | 0 | 0 | 0 | 0 | 0 | 0 | 0 | 0 | |

- **Bits 7..0 – EEDR7..0: EEPROM Data**

For the EEPROM write operation, the EEDR Register contains the data to be written to the EEPROM in the address given by the EEAR Register. For the EEPROM read operation, the EEDR contains the data read out from the EEPROM at the address given by EEAR.

EEPROM Control Register – EECR

| | | | | | | | | | |
|---------------|---|---|---|---|--------------|--------------|-------------|-------------|-------------|
| Bit | 7 | 6 | 5 | 4 | 3 | 2 | 1 | 0 | |
| | - | | | | EERIE | EEMWE | EEWE | EERE | EECR |
| Read/Write | R | R | R | R | R/W | R/W | R/W | R/W | |
| Initial Value | 0 | 0 | 0 | 0 | 0 | 0 | X | 0 | |

- **Bits 7..4 – Res: Reserved Bits**

These bits are reserved bits in the ATmega128 and will always read as zero.

- **Bit 3 – EERIE: EEPROM Ready Interrupt Enable**

Writing EERIE to one enables the EEPROM Ready Interrupt if the I-bit in SREG is set. Writing EERIE to zero disables the interrupt. The EEPROM Ready interrupt generates a constant interrupt when EEWE is cleared.

- **Bit 2 – EEMWE: EEPROM Master Write Enable**

The EEMWE bit determines whether setting EEWE to one causes the EEPROM to be written. When EEMWE is written to one, writing EEWE to one within four clock cycles will write data to the EEPROM at the selected address. If EEMWE is zero, writing EEWE to one will have no effect. When EEMWE has been written to one by software, hardware clears the bit to zero after four clock cycles. See the description of the EEWE bit for an EEPROM write procedure.

- **Bit 1 – EEWE: EEPROM Write Enable**

The EEPROM Write Enable Signal EEWE is the write strobe to the EEPROM. When address and data are correctly set up, the EEWE bit must be set to write the value into the EEPROM. The EEMWE bit must be set when the logical one is written to EEWE, otherwise no EEPROM write takes place. The following procedure should be followed when writing the EEPROM (the order of steps 3 and 4 is not essential):

1. Wait until EEWE becomes zero.
2. Wait until SPMEN in SPMCSR becomes zero.
3. Write new EEPROM address to EEAR (optional).
4. Write new EEPROM data to EEDR (optional).
5. Write a logical one to the EEMWE bit while writing a zero to EEWE in EECR.
6. Within four clock cycles after setting EEMWE, write a logical one to EEWE.

The EEPROM can not be programmed during a CPU write to the Flash memory. The software must check that the Flash programming is completed before initiating a new EEPROM write. Step 2 is only relevant if the software contains a boot loader allowing the CPU to program the Flash. If the Flash is never being updated by the CPU, step 2 can be omitted. See [“Boot Loader Support – Read-While-Write Self-Programming” on page 273](#) for details about boot programming.

Caution: An interrupt between step 5 and step 6 will make the write cycle fail, since the EEPROM Master Write Enable will time-out. If an interrupt routine accessing the EEPROM is interrupting another EEPROM access, the EEAR or EEDR Register will be modified, causing the interrupted EEPROM access to fail. It is recommended to have the global interrupt flag cleared during the four last steps to avoid these problems.

When the write access time has elapsed, the EEWB bit is cleared by hardware. The user software can poll this bit and wait for a zero before writing the next byte. When EEWB has been set, the CPU is halted for two cycles before the next instruction is executed.

- **Bit 0 – EERE: EEPROM Read Enable**

The EEPROM Read Enable Signal EERE is the read strobe to the EEPROM. When the correct address is set up in the EEAR Register, the EERE bit must be written to a logic one to trigger the EEPROM read. The EEPROM read access takes one instruction, and the requested data is available immediately. When the EEPROM is read, the CPU is halted for four cycles before the next instruction is executed.

The user should poll the EEWB bit before starting the read operation. If a write operation is in progress, it is neither possible to read the EEPROM, nor to change the EEAR Register.

The calibrated Oscillator is used to time the EEPROM accesses. [Table 2](#) lists the typical programming time for EEPROM access from the CPU.

Table 2. EEPROM Programming Time

| Symbol | Number of Calibrated RC Oscillator Cycles ⁽¹⁾ | Typ Programming Time |
|-------------------------|--|----------------------|
| EEPROM Write (from CPU) | 8448 | 8.5ms |

Note: 1. Uses 1MHz clock, independent of CKSEL-fuse settings.

The following code examples show one assembly and one C function for writing to the EEPROM. The examples assume that interrupts are controlled (for example, by disabling interrupts globally) so that no interrupts will occur during execution of these functions. The examples also assume that no flash boot loader is present in the software. If such code is present, the EEPROM write function must also wait for any ongoing SPM command to finish.

Assembly Code Example

```
EEPROM_write:
    ; Wait for completion of previous write
    sbic EECR,EEWE
    rjmp EEPROM_write
    ; Set up address (r18:r17) in address register
    out EEARH, r18
    out EEARL, r17
    ; Write data (r16) to data register
    out EEDR,r16
    ; Write logical one to EEMWE
    sbi EECR,EEMWE
    ; Start eeprom write by setting EEWE
    sbi EECR,EEWE
    ret
```

C Code Example

```
void EEPROM_write(unsigned int uiAddress, unsigned char ucData)
{
    /* Wait for completion of previous write */
    while((EECR & (1<<EEWE))
        ;
    /* Set up address and data registers */
    EEAR = uiAddress;
    EEDR = ucData;
    /* Write logical one to EEMWE */
    EECR |= (1<<EEMWE);
    /* Start eeprom write by setting EEWE */
    EECR |= (1<<EEWE);
}
```

The next code examples show assembly and C functions for reading the EEPROM. The examples assume that interrupts are controlled so that no interrupts will occur during execution of these functions.

Assembly Code Example

```
EEPROM_read:
    ; Wait for completion of previous write
    sbic EECR,EEWE
    rjmp EEPROM_read
    ; Set up address (r18:r17) in address register
    out EEARH, r18
    out EEARL, r17
    ; Start eeprom read by writing EERE
    sbi EECR,EERE
    ; Read data from data register
    in r16,EEDR
    ret
```

C Code Example

```
unsigned char EEPROM_read(unsigned int uiAddress)
{
    /* Wait for completion of previous write */
    while(EECR & (1<<EEWE))
        ;
    /* Set up address register */
    EEAR = uiAddress;
    /* Start eeprom read by writing EERE */
    EECR |= (1<<EERE);
    /* Return data from data register */
    return EEDR;
}
```

EEPROM Write During Power-down Sleep Mode

When entering Power-down sleep mode while an EEPROM write operation is active, the EEPROM write operation will continue, and will complete before the write access time has passed. However, when the write operation is completed, the Oscillator continues running, and as a consequence, the device does not enter Power-down entirely. It is therefore recommended to verify that the EEPROM write operation is completed before entering Power-down.

Preventing EEPROM Corruption

During periods of low V_{CC} , the EEPROM data can be corrupted because the supply voltage is too low for the CPU and the EEPROM to operate properly. These issues are the same as for board level systems using EEPROM, and the same design solutions should be applied.

An EEPROM data corruption can be caused by two situations when the voltage is too low. First, a regular write sequence to the EEPROM requires a minimum voltage to operate correctly. Secondly, the CPU itself can execute instructions incorrectly, if the supply voltage is too low.

EEPROM data corruption can easily be avoided by following this design recommendation:

Keep the AVR RESET active (low) during periods of insufficient power supply voltage. This can be done by enabling the internal Brown-out Detector (BOD). If a reset occurs while a write oper-

ation is in progress, the write operation will be completed provided that the power supply voltage is sufficient.

I/O Memory

The I/O space definition of the ATmega128 is shown in [“Register Summary” on page 362](#).

All Atmel® AVR® ATmega128 I/Os and peripherals are placed in the I/O space. All I/O locations may be accessed by the LD/LDS/LDD and ST/STS/STD instructions, transferring data between the 32 general purpose working registers and the I/O space. I/O registers within the address range \$00 - \$1F are directly bit-accessible using the SBI and CBI instructions. In these registers, the value of single bits can be checked by using the SBIS and SBIC instructions. Refer to the instruction set section for more details. When using the I/O specific commands IN and OUT, the I/O addresses \$00 - \$3F must be used. When addressing I/O registers as data space using LD and ST instructions, \$20 must be added to these addresses. The ATmega128 is a complex microcontroller with more peripheral units than can be supported within the 64 location reserved in Opcode for the IN and OUT instructions. For the Extended I/O space from \$60 - \$FF in SRAM, only the ST/STS/STD and LD/LDS/LDD instructions can be used. The Extended I/O space is replaced with SRAM locations when the ATmega128 is in the ATmega103 compatibility mode.

For compatibility with future devices, reserved bits should be written to zero if accessed. Reserved I/O memory addresses should never be written.

Some of the status flags are cleared by writing a logical one to them. Note that the CBI and SBI instructions will operate on all bits in the I/O register, writing a one back into any flag read as set, thus clearing the flag. The CBI and SBI instructions work with registers \$00 to \$1F only.

The I/O and peripherals control registers are explained in later sections.

External Memory Interface

With all the features the External Memory Interface provides, it is well suited to operate as an interface to memory devices such as External SRAM and Flash, and peripherals such as LCD-display, A/D, and D/A. The main features are:

- **Four different wait-state settings (including no wait-state).**
- **Independent wait-state setting for different extErnal Memory sectors (configurable sector size).**
- **The number of bits dedicated to address high byte is selectable.**
- **Bus-keepers on data lines to minimize current consumption (optional).**

Overview

When the eXternal MEMory (XMEM) is enabled, address space outside the internal SRAM becomes available using the dedicated External Memory pins (see [Figure 1 on page 2](#), [Table 27 on page 72](#), [Table 33 on page 76](#), and [Table 45 on page 84](#)). The memory configuration is shown in [Figure 11](#).

Figure 11. External Memory with Sector Select



Note: ATmega128 in non ATmega103 compatibility mode: Memory Configuration A is available (Memory Configuration B N/A)
 ATmega128 in ATmega103 compatibility mode: Memory Configuration B is available (Memory Configuration A N/A)

ATmega103 Compatibility

Both External Memory Control Registers (XMCRA and XMCRB) are placed in Extended I/O space. In ATmega103 compatibility mode, these registers are not available, and the features selected by these registers are not available. The device is still ATmega103 compatible, as these features did not exist in ATmega103. The limitations in ATmega103 compatibility mode are:

- Only two wait-states settings are available (SRW1n = 0b00 and SRW1n = 0b01).
- The number of bits that are assigned to address high byte are fixed.
- The External Memory section can not be divided into sectors with different wait-state settings.
- Bus-keeper is not available.
- \overline{RD} , \overline{WR} and ALE pins are output only (Port G in ATmega128).

Using the External Memory Interface

The interface consists of:

- AD7:0: Multiplexed low-order address bus and data bus.
- A15:8: High-order address bus (configurable number of bits).
- ALE: Address latch enable.
- \overline{RD} : Read strobe.
- \overline{WR} : Write strobe.

The control bits for the External Memory Interface are located in three registers, the MCU Control Register – MCUCR, the External Memory Control Register A – XMCRA, and the External Memory Control Register B – XMCRB.

When the XMEM interface is enabled, the XMEM interface will override the setting in the data direction registers that corresponds to the ports dedicated to the XMEM interface. For details about the port override, see the alternate functions in section “I/O Ports” on page 65. The XMEM interface will auto-detect whether an access is internal or external. If the access is external, the XMEM interface will output address, data, and the control signals on the ports according to [Figure 13](#) (this figure shows the wave forms without wait-states). When ALE goes from high-to-low, there is a valid address on AD7:0. ALE is low during a data transfer. When the XMEM interface is enabled, also an internal access will cause activity on address, data and ALE ports, but the \overline{RD} and \overline{WR} strobes will not toggle during internal access. When the External Memory Interface is disabled, the normal pin and data direction settings are used. Note that when the XMEM interface is disabled, the address space above the internal SRAM boundary is not mapped into the internal SRAM. [Figure 12](#) illustrates how to connect an external SRAM to the AVR using an octal latch (typically “74 x 573” or equivalent) which is transparent when G is high.

Address Latch Requirements

Due to the high-speed operation of the XRAM interface, the address latch must be selected with care for system frequencies above 8MHz @ 4V and 4MHz @ 2.7V. When operating at conditions above these frequencies, the typical old style 74HC series latch becomes inadequate. The External Memory Interface is designed in compliance to the 74AHC series latch. However, most latches can be used as long they comply with the main timing parameters. The main parameters for the address latch are:

- D to Q propagation delay (t_{PD}).
- Data setup time before G low (t_{SU}).
- Data (address) hold time after G low (t_{TH}).

The External Memory Interface is designed to guaranty minimum address hold time after G is asserted low of $t_h = 5$ ns. Refer to t_{LAXX_LD}/t_{LLAXX_ST} in “[External Data Memory Timing](#)” Tables 137 through Tables 144 on pages 328 - 330. The D-to-Q propagation delay (t_{PD}) must be taken into consideration when calculating the access time requirement of the external component. The data setup time before G low (t_{SU}) must not exceed address valid to ALE low (t_{AVLLC}) minus PCB wiring delay (dependent on the capacitive load).

Figure 12. External SRAM Connected to the AVR



Pull-up and Bus-keeper

The pull-ups on the AD7:0 ports may be activated if the corresponding Port register is written to one. To reduce power consumption in sleep mode, it is recommended to disable the pull-ups by writing the Port register to zero before entering sleep.

The XMEM interface also provides a bus-keeper on the AD7:0 lines. The bus-keeper can be disabled and enabled in software as described in “External Memory Control Register B – XMCRB” on page 32. When enabled, the bus-keeper will ensure a defined logic level (zero or one) on the AD7:0 bus when these lines would otherwise be tri-stated by the XMEM interface.

Timing

External Memory devices have different timing requirements. To meet these requirements, the ATmega128 XMEM interface provides four different wait-states as shown in Table 4. It is important to consider the timing specification of the External Memory device before selecting the wait-state. The most important parameters are the access time for the external memory compared to the set-up requirement of the ATmega128. The access time for the External Memory is defined to be the time from receiving the chip select/address until the data of this address actually is driven on the bus. The access time cannot exceed the time from the ALE pulse must be asserted low until data is stable during a read sequence (See $t_{LLRL} + t_{RLRH} - t_{DVRH}$ in Tables 137 through Tables 144 on pages 328 - 330). The different wait-states are set up in software. As an additional feature, it is possible to divide the external memory space in two sectors with individual wait-state settings. This makes it possible to connect two different memory devices with different timing requirements to the same XMEM interface. For XMEM interface timing details, please refer to Table 137 to Table 144 and Figure 157 to Figure 160 in the “External Data Memory Timing” on page 328.

Note that the XMEM interface is asynchronous and that the waveforms in the following figures are related to the internal system clock. The skew between the internal and external clock (XTAL1) is not guaranteed (varies between devices temperature, and supply voltage). Consequently, the XMEM interface is not suited for synchronous operation.

Figure 13. External Data Memory Cycles without Wait-state (SRWn1=0 and SRWn0=0)



Note: 1. SRWn1 = SRW11 (upper sector) or SRW01 (lower sector), SRWn0 = SRW10 (upper sector) or SRW00 (lower sector). The ALE pulse in period T4 is only present if the next instruction accesses the RAM (internal or external).

Figure 14. External Data Memory Cycles with $SRWn1 = 0$ and $SRWn0 = 1$ ⁽¹⁾



Note: 1. $SRWn1 = SRW11$ (upper sector) or $SRW01$ (lower sector), $SRWn0 = SRW10$ (upper sector) or $SRW00$ (lower sector).
The ALE pulse in period T5 is only present if the next instruction accesses the RAM (internal or external).

Figure 15. External Data Memory Cycles with $SRWn1 = 1$ and $SRWn0 = 0$ ⁽¹⁾



Note: 1. $SRWn1 = SRW11$ (upper sector) or $SRW01$ (lower sector), $SRWn0 = SRW10$ (upper sector) or $SRW00$ (lower sector).
The ALE pulse in period T6 is only present if the next instruction accesses the RAM (internal or external).

Figure 16. External Data Memory Cycles with SRWn1 = 1 and SRWn0 = 1⁽¹⁾



Note: 1. SRWn1 = SRW11 (upper sector) or SRW01 (lower sector), SRWn0 = SRW10 (upper sector) or SRW00 (lower sector).
The ALE pulse in period T7 is only present if the next instruction accesses the RAM (internal or external).

XMEM Register Description

MCU Control Register – MCUCR

| | | | | | | | | | |
|---------------|------------|--------------|-----------|------------|------------|------------|--------------|-------------|--------------|
| Bit | 7 | 6 | 5 | 4 | 3 | 2 | 1 | 0 | |
| | SRE | SRW10 | SE | SM1 | SM0 | SM2 | IVSEL | IVCE | MCUCR |
| Read/Write | R/W | R/W | R/W | R/W | R/W | R/W | R/W | R/W | |
| Initial Value | 0 | 0 | 0 | 0 | 0 | 0 | 0 | 0 | |

- **Bit 7 – SRE: External SRAM/XMEM Enable**

Writing SRE to one enables the External Memory Interface. The pin functions AD7:0, A15:8, ALE, \overline{WR} , and \overline{RD} are activated as the alternate pin functions. The SRE bit overrides any pin direction settings in the respective data direction registers. Writing SRE to zero, disables the External Memory Interface and the normal pin and data direction settings are used.

- **Bit 6 – SRW10: Wait-state Select Bit**

For a detailed description in non-ATmega103 compatibility mode, see common description for the SRWn bits below (XMCRA description). In ATmega103 compatibility mode, writing SRW10 to one enables the wait-state and one extra cycle is added during read/write strobe as shown in Figure 14.

External Memory Control Register A – XMCRA

| | | | | | | | | | |
|---------------|---|-------------|-------------|-------------|--------------|--------------|--------------|---|--------------|
| Bit | 7 | 6 | 5 | 4 | 3 | 2 | 1 | 0 | |
| | – | SRL2 | SRL1 | SRL0 | SRW01 | SRW00 | SRW11 | – | XMCRA |
| Read/Write | R | R/W | R/W | R/W | R/W | R/W | R/W | R | |
| Initial Value | 0 | 0 | 0 | 0 | 0 | 0 | 0 | 0 | |

- **Bit 7 – Res: Reserved Bit**

This is a reserved bit and will always read as zero. When writing to this address location, write this bit to zero for compatibility with future devices.

- **Bit 6..4 – SRL2, SRL1, SRL0: Wait-state Sector Limit**

It is possible to configure different wait-states for different External Memory addresses. The external memory address space can be divided in two sectors that have separate wait-state bits. The SRL2, SRL1, and SRL0 bits select the split of the sectors, see [Table 3](#) and [Figure 11](#). By default, the SRL2, SRL1, and SRL0 bits are set to zero and the entire external memory address space is treated as one sector. When the entire SRAM address space is configured as one sector, the wait-states are configured by the SRW11 and SRW10 bits.

Table 3. Sector limits with different settings of SRL2..0

| SRL2 | SRL1 | SRL0 | Sector Limits |
|------|------|------|--|
| 0 | 0 | 0 | Lower sector = N/A Upper sector = 0x1100 - 0xFFFF |
| 0 | 0 | 1 | Lower sector = 0x1100 - 0x1FFF Upper sector = 0x2000 - 0xFFFF |
| 0 | 1 | 0 | Lower sector = 0x1100 - 0x3FFF Upper sector = 0x4000 - 0xFFFF |
| 0 | 1 | 1 | Lower sector = 0x1100 - 0x5FFF Upper sector = 0x6000 - 0xFFFF |
| 1 | 0 | 0 | Lower sector = 0x1100 - 0x7FFF Upper sector = 0x8000 - 0xFFFF |
| 1 | 0 | 1 | Lower sector = 0x1100 - 0x9FFF Upper sector = 0xA000 - 0xFFFF |
| 1 | 1 | 0 | Lower sector = 0x1100 - 0xBFFF Upper sector = 0xC000 - 0xFFFF |
| 1 | 1 | 1 | Lower sector = 0x1100 - 0xDFFF Upper sector = 0xE000 - 0xFFFF |

- **Bit 1 and Bit 6 MCUCR – SRW11, SRW10: Wait-state Select Bits for Upper Sector**

The SRW11 and SRW10 bits control the number of wait-states for the upper sector of the external memory address space, see [Table 4](#).

- **Bit 3..2 – SRW01, SRW00: Wait-state Select Bits for Lower Sector**

The SRW01 and SRW00 bits control the number of wait-states for the lower sector of the external memory address space, see [Table 4](#).

Table 4. Wait States⁽¹⁾

| SRWn1 | SRWn0 | Wait States |
|-------|-------|---|
| 0 | 0 | No wait-states |
| 0 | 1 | Wait one cycle during read/write strobe |
| 1 | 0 | Wait two cycles during read/write strobe |
| 1 | 1 | Wait two cycles during read/write and wait one cycle before driving out new address |

Note: 1. n = 0 or 1 (lower/upper sector).

For further details of the timing and wait-states of the External Memory Interface, see Figures 13 through Figures 16 for how the setting of the SRW bits affects the timing.

- **Bit 0 – Res: Reserved Bit**

This is a reserved bit and will always read as zero. When writing to this address location, write this bit to zero for compatibility with future devices.

External Memory Control Register B – XMCRB

| | | | | | | | | | |
|---------------|------|---|---|---|---|------|------|------|-------|
| Bit | 7 | 6 | 5 | 4 | 3 | 2 | 1 | 0 | |
| | XMBK | – | – | – | – | XMM2 | XMM1 | XMM0 | XMCRB |
| Read/Write | R/W | R | R | R | R | R/W | R/W | R/W | |
| Initial Value | 0 | 0 | 0 | 0 | 0 | 0 | 0 | 0 | |

- **Bit 7– XMBK: External Memory Bus-keeper Enable**

Writing XMBK to one enables the bus keeper on the AD7:0 lines. When the bus keeper is enabled, it will ensure a defined logic level (zero or one) on AD7:0 when they would otherwise be tri-stated. Writing XMBK to zero disables the bus keeper. XMBK is not qualified with SRE, so even if the XMEM interface is disabled, the bus keepers are still activated as long as XMBK is one.

- **Bit 6..4 – Res: Reserved Bits**

These are reserved bits and will always read as zero. When writing to this address location, write these bits to zero for compatibility with future devices.

- **Bit 2..0 – XMM2, XMM1, XMM0: External Memory High Mask**

When the External Memory is enabled, all Port C pins are default used for the high address byte. If the full 60 Kbyte address space is not required to access the External Memory, some, or all, Port C pins can be released for normal Port Pin function as described in [Table 5](#). As described in [“Using all 64 Kbyte Locations of External Memory” on page 34](#), it is possible to use the XMMn bits to access all 64 Kbyte locations of the External Memory.

Table 5. Port C Pins Released as Normal Port Pins when the External Memory is Enabled

| XMM2 | XMM1 | XMM0 | # Bits for External Memory Address | Released Port Pins |
|------|------|------|------------------------------------|--------------------|
| 0 | 0 | 0 | 8 (Full 60 Kbyte space) | None |
| 0 | 0 | 1 | 7 | PC7 |
| 0 | 1 | 0 | 6 | PC7 - PC6 |
| 0 | 1 | 1 | 5 | PC7 - PC5 |
| 1 | 0 | 0 | 4 | PC7 - PC4 |
| 1 | 0 | 1 | 3 | PC7 - PC3 |
| 1 | 1 | 0 | 2 | PC7 - PC2 |
| 1 | 1 | 1 | No Address high bits | Full Port C |

Using all Locations of External Memory Smaller than 64 Kbyte

Since the external memory is mapped after the internal memory as shown in [Figure 11](#), the external memory is not addressed when addressing the first 4,352 bytes of data space. It may appear that the first 4,352 bytes of the external memory are inaccessible (external memory addresses 0x0000 to 0x10FF). However, when connecting an external memory smaller than 64 Kbyte, for example 32 Kbyte, these locations are easily accessed simply by addressing from address 0x8000 to 0x90FF. Since the External Memory Address bit A15 is not connected to the external memory, addresses 0x8000 to 0x90FF will appear as addresses 0x0000 to 0x10FF for the external memory. Addressing above address 0x90FF is not recommended, since this will address an external memory location that is already accessed by another (lower) address. To the Application software, the external 32 Kbyte memory will appear as one linear 32 Kbyte address space from 0x1100 to 0x90FF. This is illustrated in [Figure 17](#). Memory configuration B refers to the ATmega103 compatibility mode, configuration A to the non-compatible mode.

When the device is set in ATmega103 compatibility mode, the internal address space is 4,096 bytes. This implies that the first 4,096 bytes of the external memory can be accessed at

addresses 0x8000 to 0x8FFF. To the Application software, the external 32 Kbyte memory will appear as one linear 32 Kbyte address space from 0x1000 to 0x8FFF.

Figure 17. Address Map with 32 Kbyte External Memory



Using all 64 Kbyte Locations of External Memory

Since the External Memory is mapped after the Internal Memory as shown in [Figure 11](#), only 60 Kbyte of External Memory is available by default (address space 0x0000 to 0x10FF is reserved for internal memory). However, it is possible to take advantage of the entire External Memory by masking the higher address bits to zero. This can be done by using the XMMn bits and control by software the most significant bits of the address. By setting Port C to output 0x00, and releasing the most significant bits for normal Port Pin operation, the Memory Interface will address 0x0000 - 0x1FFF. See the following code examples.

Assembly Code Example⁽¹⁾

```

; OFFSET is defined to 0x2000 to ensure
; external memory access
; Configure Port C (address high byte) to
; output 0x00 when the pins are released
; for normal Port Pin operation

ldi r16, 0xFF
out DDRC, r16
ldi r16, 0x00
out PORTC, r16
; release PC7:5
ldi r16, (1<<XMM1) | (1<<XMM0)
sts XMCRB, r16
; write 0xAA to address 0x0001 of external
; memory
ldi r16, 0xaa
sts 0x0001+OFFSET, r16
; re-enable PC7:5 for external memory
ldi r16, (0<<XMM1) | (0<<XMM0)
sts XMCRB, r16
; store 0x55 to address (OFFSET + 1) of
; external memory
ldi r16, 0x55
sts 0x0001+OFFSET, r16

```

C Code Example⁽¹⁾

```

#define OFFSET 0x2000

void XRAM_example(void)
{
    unsigned char *p = (unsigned char *) (OFFSET + 1);

    DDRC = 0xFF;
    PORTC = 0x00;

    XMCRB = (1<<XMM1) | (1<<XMM0);

    *p = 0xaa;

    XMCRB = 0x00;

    *p = 0x55;
}

```

Note: 1. See “About Code Examples” on page 8.

Care must be exercised using this option as most of the memory is masked away.

System Clock and Clock Options

Clock Systems and their Distribution

Figure 18 presents the principal clock systems in the AVR and their distribution. All of the clocks need not be active at a given time. In order to reduce power consumption, the clocks to modules not being used can be halted by using different sleep modes, as described in “Power Management and Sleep Modes” on page 44. The clock systems are detailed below.

Figure 18. Clock Distribution



CPU Clock – clk_{CPU}

The CPU clock is routed to parts of the system concerned with operation of the AVR core. Examples of such modules are the General Purpose Register File, the Status Register and the data memory holding the Stack Pointer. Halting the CPU clock inhibits the core from performing general operations and calculations.

I/O Clock – $clk_{I/O}$

The I/O clock is used by the majority of the I/O modules, like Timer/Counters, SPI, and USART. The I/O clock is also used by the External Interrupt module, but note that some external interrupts are detected by asynchronous logic, allowing such interrupts to be detected even if the I/O clock is halted. Also note that address recognition in the TWI module is carried out asynchronously when $clk_{I/O}$ is halted, enabling TWI address reception in all sleep modes.

Flash Clock – clk_{FLASH}

The Flash clock controls operation of the Flash interface. The Flash clock is usually active simultaneously with the CPU clock.

Asynchronous Timer Clock – clk_{ASY}

The Asynchronous Timer clock allows the Asynchronous Timer/Counter to be clocked directly from an external 32kHz clock crystal. The dedicated clock domain allows using this Timer/Counter as a real-time counter even when the device is in sleep mode.

ADC Clock – clk_{ADC}

The ADC is provided with a dedicated clock domain. This allows halting the CPU and I/O clocks in order to reduce noise generated by digital circuitry. This gives more accurate ADC conversion results.

XTAL Divide Control Register – XDIV

The XTAL Divide Control Register is used to divide the Source clock frequency by a number in the range 2 - 129. This feature can be used to decrease power consumption when the requirement for processing power is low.

| | | | | | | | | | |
|---------------|---------------|--------------|--------------|--------------|--------------|--------------|--------------|--------------|-------------|
| Bit | 7 | 6 | 5 | 4 | 3 | 2 | 1 | 0 | |
| | XDIVEN | XDIV6 | XDIV5 | XDIV4 | XDIV3 | XDIV2 | XDIV1 | XDIV0 | XDIV |
| Read/Write | R/W | R/W | R/W | R/W | R/W | R/W | R/W | R/W | |
| Initial Value | 0 | 0 | 0 | 0 | 0 | 0 | 0 | 0 | |

- **Bit 7 – XDIVEN: XTAL Divide Enable**

When the XDIVEN bit is written one, the clock frequency of the CPU and all peripherals ($clk_{I/O}$, clk_{ADC} , clk_{CPU} , clk_{FLASH}) is divided by the factor defined by the setting of XDIV6 - XDIV0. This bit can be written run-time to vary the clock frequency as suitable to the application.

- **Bits 6..0 – XDIV6..XDIV0: XTAL Divide Select Bits 6 - 0**

These bits define the division factor that applies when the XDIVEN bit is set (one). If the value of these bits is denoted d , the following formula defines the resulting CPU and peripherals clock frequency f_{CLK} :

$$f_{CLK} = \frac{\text{Source clock}}{129 - d}$$

The value of these bits can only be changed when XDIVEN is zero. When XDIVEN is written to one, the value written simultaneously into XDIV6..XDIV0 is taken as the division factor. When XDIVEN is written to zero, the value written simultaneously into XDIV6..XDIV0 is rejected. As the divider divides the master clock input to the MCU, the speed of all peripherals is reduced when a division factor is used.

When the system clock is divided, Timer/Counter0 can be used with Asynchronous clock only. The frequency of the asynchronous clock must be lower than 1/4th of the frequency of the scaled down Source clock. Otherwise, interrupts may be lost, and accessing the Timer/Counter0 registers may fail.

Clock Sources

The device has the following clock source options, selectable by Flash fuse bits as shown below. The clock from the selected source is input to the AVR clock generator, and routed to the appropriate modules.

Table 6. Device Clocking Options Select

| Device Clocking Option | CKSEL3..0 ⁽¹⁾ |
|------------------------------------|--------------------------|
| External Crystal/Ceramic Resonator | 1111 - 1010 |
| External Low-frequency Crystal | 1001 |
| External RC Oscillator | 1000 - 0101 |
| Calibrated Internal RC Oscillator | 0100 - 0001 |
| External Clock | 0000 |

Note: 1. For all fuses “1” means unprogrammed while “0” means programmed.

The various choices for each clocking option is given in the following sections. When the CPU wakes up from Power-down or Power-save, the selected clock source is used to time the start-up, ensuring stable Oscillator operation before instruction execution starts. When the CPU starts from reset, there is as an additional delay allowing the power to reach a stable level before commencing normal operation. The Watchdog Oscillator is used for timing this real-time part of the start-up time. The number of WDT Oscillator cycles used for each time-out is shown in [Table 7](#). The frequency of the Watchdog Oscillator is voltage dependent as shown in the [“Typical Characteristics” on page 333](#).

Table 7. Number of Watchdog Oscillator Cycles

| Typical Time-out ($V_{CC} = 5.0V$) | Typical Time-Out ($V_{CC} = 3.0V$) | Number of Cycles |
|--------------------------------------|--------------------------------------|------------------|
| 4.1ms | 4.3ms | 4K (4,096) |
| 65ms | 69ms | 64K (65,536) |

Default Clock Source

The device is shipped with CKSEL = “0001” and SUT = “10”. The default clock source setting is therefore the Internal RC Oscillator with longest startup time. This default setting ensures that all users can make their desired clock source setting using an In-System or Parallel Programmer.

Crystal Oscillator

XTAL1 and XTAL2 are input and output, respectively, of an inverting amplifier which can be configured for use as an On-chip Oscillator, as shown in Figure 19. Either a quartz crystal or a ceramic resonator may be used. The CKOPT fuse selects between two different Oscillator Amplifier modes. When CKOPT is programmed, the Oscillator output will oscillate with a full rail-to-rail swing on the output. This mode is suitable when operating in a very noisy environment or when the output from XTAL2 drives a second clock buffer. This mode has a wide frequency range. When CKOPT is unprogrammed, the Oscillator has a smaller output swing. This reduces power consumption considerably. This mode has a limited frequency range and it can not be used to drive other clock buffers.

For resonators, the maximum frequency is 8MHz with CKOPT unprogrammed and 16MHz with CKOPT programmed. C1 and C2 should always be equal for both crystals and resonators. The optimal value of the capacitors depends on the crystal or resonator in use, the amount of stray capacitance, and the electromagnetic noise of the environment. Some initial guidelines for choosing capacitors for use with crystals are given in Table 8. For ceramic resonators, the capacitor values given by the manufacturer should be used.

Figure 19. Crystal Oscillator Connections



The Oscillator can operate in three different modes, each optimized for a specific frequency range. The operating mode is selected by the fuses CKSEL3..1 as shown in Table 8.

Table 8. Crystal Oscillator Operating Modes

| CKOPT | CKSEL3..1 | Frequency Range (MHz) | Recommended Range for Capacitors C1 and C2 for Use with Crystals |
|-------|--------------------|-----------------------|--|
| 1 | 101 ⁽¹⁾ | 0.4 - 0.9 | – |
| 1 | 110 | 0.9 - 3.0 | 12 - 22pF |
| 1 | 111 | 3.0 - 8.0 | 12 - 22pF |
| 0 | 101, 110, 111 | 1.0 - | 12 - 22pF |

Note: 1. This option should not be used with crystals, only with ceramic resonators.

The CKSEL0 fuse together with the SUT1..0 fuses select the start-up times as shown in Table 9.

Table 9. Start-up Times for the Crystal Oscillator Clock Selection

| CKSELO | SUT1..0 | Start-up Time from Power-down and Power-save | Additional Delay from Reset ($V_{CC} = 5.0V$) | Recommended Usage |
|--------|---------|--|---|---|
| 0 | 00 | 258 CK ⁽¹⁾ | 4.1ms | Ceramic resonator, fast rising power |
| 0 | 01 | 258 CK ⁽¹⁾ | 65ms | Ceramic resonator, slowly rising power |
| 0 | 10 | 1K CK ⁽²⁾ | – | Ceramic resonator, BOD enabled |
| 0 | 11 | 1K CK ⁽²⁾ | 4.0ms | Ceramic resonator, fast rising power |
| 1 | 00 | 1K CK ⁽²⁾ | 65ms | Ceramic resonator, slowly rising power |
| 1 | 01 | 16K CK | – | Crystal Oscillator, BOD enabled |
| 1 | 10 | 16K CK | 4.1ms | Crystal Oscillator, fast rising power |
| 1 | 11 | 16K CK | 65ms | Crystal Oscillator, slowly rising power |

- Notes:
1. These options should only be used when not operating close to the maximum frequency of the device, and only if frequency stability at start-up is not important for the application. These options are not suitable for crystals.
 2. These options are intended for use with ceramic resonators and will ensure frequency stability at start-up. They can also be used with crystals when not operating close to the maximum frequency of the device, and if frequency stability at start-up is not important for the application.

Low-frequency Crystal Oscillator

To use a 32.768kHz watch crystal as the clock source for the device, the Low-frequency Crystal Oscillator must be selected by setting the CKSEL fuses to “1001”. The crystal should be connected as shown in [Figure 19](#). By programming the CKOPT fuse, the user can enable internal capacitors on XTAL1 and XTAL2, thereby removing the need for external capacitors. The internal capacitors have a nominal value of 36pF.

When this Oscillator is selected, start-up times are determined by the SUT fuses as shown in [Table 10](#).

Table 10. Start-up Times for the Low-frequency Crystal Oscillator Clock Selection

| SUT1..0 | Start-up Time from Power-down and Power-save | Additional Delay from Reset ($V_{CC} = 5.0V$) | Recommended Usage |
|---------|--|---|----------------------------------|
| 00 | 1K CK ⁽¹⁾ | 4.1ms | Fast rising power or BOD enabled |
| 01 | 1K CK ⁽¹⁾ | 65ms | Slowly rising power |
| 10 | 32K CK | 65ms | Stable frequency at start-up |
| 11 | Reserved | | |

- Note:
1. These options should only be used if frequency stability at start-up is not important for the application.

External RC Oscillator

For timing insensitive applications, the External RC configuration shown in [Figure 20](#) can be used. The frequency is roughly estimated by the equation $f = 1/(3RC)$. C should be at least 22pF. By programming the CKOPT fuse, the user can enable an internal 36pF capacitor between XTAL1 and GND, thereby removing the need for an external capacitor. For more information on Oscillator operation and details on how to choose R and C, refer to the External RC Oscillator application note.

Figure 20. External RC Configuration

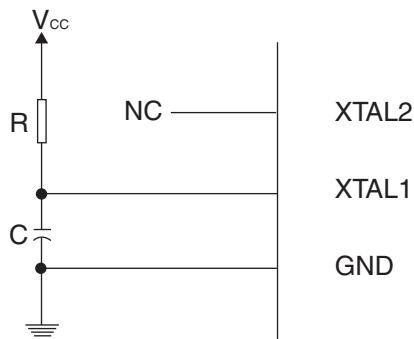

The Oscillator can operate in four different modes, each optimized for a specific frequency range. The operating mode is selected by the fuses CKSEL3..0 as shown in [Table 11](#).

Table 11. External RC Oscillator Operating Modes

| CKSEL3..0 | Frequency Range (MHz) |
|-----------|-----------------------|
| 0101 | 0.1 - 0.9 |
| 0110 | 0.9 - 3.0 |
| 0111 | 3.0 - 8.0 |
| 1000 | 8.0 - 12.0 |

When this Oscillator is selected, start-up times are determined by the SUT fuses as shown in [Table 12](#).

Table 12. Start-Up Times for the External RC Oscillator Clock Selection

| SUT1..0 | Start-up Time from Power-down and Power-save | Additional Delay from Reset ($V_{CC} = 5.0V$) | Recommended Usage |
|---------|--|---|----------------------------------|
| 00 | 18 CK | – | BOD enabled |
| 01 | 18 CK | 4.1ms | Fast rising power |
| 10 | 18 CK | 65ms | Slowly rising power |
| 11 | 6 CK ⁽¹⁾ | 4.1ms | Fast rising power or BOD enabled |

Note: 1. This option should not be used when operating close to the maximum frequency of the device.

Calibrated Internal RC Oscillator

The Calibrated Internal RC Oscillator provides a fixed 1.0, 2.0, 4.0, or 8.0MHz clock. All frequencies are nominal values at 5V and 25°C. This clock may be selected as the system clock by programming the CKSEL fuses as shown in Table 13. If selected, it will operate with no external components. The CKOPT fuse should always be unprogrammed when using this clock option. During Reset, hardware loads the calibration byte for the 1MHz oscillator into the OSCCAL Register and thereby automatically calibrates the RC Oscillator. At 5V, 25°C and 1.0MHz Oscillator frequency selected, this calibration gives a frequency within ±3% of the nominal frequency. Using calibration methods as described in application notes available at www.atmel.com/avr it is possible to achieve ±1% accuracy at any given V_{CC} and Temperature. When this Oscillator is used as the chip clock, the Watchdog Oscillator will still be used for the Watchdog Timer and for the Reset Time-out. For more information on the pre-programmed calibration value, see the section “Calibration Byte” on page 289.

Table 13. Internal Calibrated RC Oscillator Operating Modes

| CKSEL3..0 | Nominal Frequency (MHz) |
|---------------------|-------------------------|
| 0001 ⁽¹⁾ | 1.0 |
| 0010 | 2.0 |
| 0011 | 4.0 |
| 0100 | 8.0 |

Note: 1. The device is shipped with this option selected.

When this Oscillator is selected, start-up times are determined by the SUT fuses as shown in Table 14. XTAL1 and XTAL2 should be left unconnected (NC).

Table 14. Start-up Times for the Internal Calibrated RC Oscillator Clock Selection

| SUT1..0 | Start-up Time from Power-down and Power-save | Additional Delay from Reset (V _{CC} = 5.0V) | Recommended Usage |
|-------------------|--|--|---------------------|
| 00 | 6 CK | – | BOD enabled |
| 01 | 6 CK | 4.1ms | Fast rising power |
| 10 ⁽¹⁾ | 6 CK | 65ms | Slowly rising power |
| 11 | Reserved | | |

Notes: 1. The device is shipped with this option selected.

Oscillator Calibration Register – OSCCAL



Note: OSCCAL Register is not available in ATmega103 compatibility mode.

• Bits 7..0 – CAL7..0: Oscillator Calibration Value

Writing the calibration byte to this address will trim the Internal Oscillator to remove process variations from the Oscillator frequency. During Reset, the 1MHz calibration value which is located in the signature row high byte (address 0x00) is automatically loaded into the OSCCAL Register. If the internal RC is used at other frequencies, the calibration values must be loaded manually. This can be done by first reading the signature row by a programmer, and then store the calibration values in the Flash or EEPROM. Then the value can be read by software and loaded into the OSCCAL Register. When OSCCAL is zero, the lowest available frequency is chosen. Writing non-zero values to this register will increase the frequency of the Internal Oscillator. Writing \$FF

to the register gives the highest available frequency. The calibrated Oscillator is used to time EEPROM and Flash access. If EEPROM or Flash is written, do not calibrate to more than 10% above the nominal frequency. Otherwise, the EEPROM or Flash write may fail. Note that the Oscillator is intended for calibration to 1.0MHz, 2.0MHz, 4.0MHz, or 8.0MHz. Tuning to other values is not guaranteed, as indicated in [Table 15](#).

Table 15. Internal RC Oscillator Frequency Range.

| OSCCAL Value | Min Frequency in Percentage of Nominal Frequency (%) | Max Frequency in Percentage of Nominal Frequency (%) |
|--------------|--|--|
| \$00 | 50 | 100 |
| \$7F | 75 | 150 |
| \$FF | 100 | 200 |

External Clock

To drive the device from an external clock source, XTAL1 should be driven as shown in [Figure 21](#). To run the device on an external clock, the CKSEL fuses must be programmed to “0000”. By programming the CKOPT fuse, the user can enable an internal 36 pF capacitor between XTAL1 and GND.

Figure 21. External Clock Drive Configuration



When this clock source is selected, start-up times are determined by the SUT fuses as shown in [Table 16](#).

Table 16. Start-up Times for the External Clock Selection

| SUT1..0 | Start-up Time from Power-down and Power-save | Additional Delay from Reset ($V_{CC} = 5.0V$) | Recommended Usage |
|---------|--|---|---------------------|
| 00 | 6 CK | – | BOD enabled |
| 01 | 6 CK | 4.1ms | Fast rising power |
| 10 | 6 CK | 65ms | Slowly rising power |
| 11 | Reserved | | |

When applying an external clock, it is required to avoid sudden changes in the applied clock frequency to ensure stable operation of the MCU. A variation in frequency of more than 2% from one clock cycle to the next can lead to unpredictable behavior. It is required to ensure that the MCU is kept in Reset during such changes in the clock frequency.

**Timer/Counter
Oscillator**

For AVR microcontrollers with Timer/Counter Oscillator pins (TOSC1 and TOSC2), the crystal is connected directly between the pins. No external capacitors are needed. The Oscillator is optimized for use with a 32.768kHz watch crystal. Applying an external clock source to TOSC1 is not recommended.

Note: The Timer/Counter Oscillator uses the same type of crystal oscillator as Low-Frequency Oscillator and the internal capacitors have the same nominal value of 36pF.

Power Management and Sleep Modes

Sleep modes enable the application to shut down unused modules in the MCU, thereby saving power. The AVR provides various sleep modes allowing the user to tailor the power consumption to the application's requirements.

To enter any of the six sleep modes, the SE bit in MCUCR must be written to logic one and a SLEEP instruction must be executed. The SM2, SM1, and SM0 bits in the MCUCR Register select which sleep mode (Idle, ADC Noise Reduction, Power-down, Power-save, Standby, or Extended Standby) will be activated by the SLEEP instruction. See [Table 17](#) for a summary. If an enabled interrupt occurs while the MCU is in a sleep mode, the MCU wakes up. The MCU is then halted for four cycles in addition to the start-up time, it executes the interrupt routine, and resumes execution from the instruction following SLEEP. The contents of the register file and SRAM are unaltered when the device wakes up from sleep. If a reset occurs during sleep mode, the MCU wakes up and executes from the Reset Vector.

[Figure 18 on page 35](#) presents the different clock systems in the ATmega128, and their distribution. The figure is helpful in selecting an appropriate sleep mode.

MCU Control Register – MCUCR

The MCU Control Register contains control bits for power management.

| | | | | | | | | | |
|---------------|--|-----|-----|-----|-----|-----|-----|-----|-------|
| Bit | 7 | 6 | 5 | 4 | 3 | 2 | 1 | 0 | |
| | SRE SRW10 SE SM1 SM0 SM2 IVSEL IVCE | | | | | | | | MCUCR |
| Read/Write | R/W | R/W | R/W | R/W | R/W | R/W | R/W | R/W | |
| Initial Value | 0 | 0 | 0 | 0 | 0 | 0 | 0 | 0 | |

- **Bit 5 – SE: Sleep Enable**

The SE bit must be written to logic one to make the MCU enter the Sleep mode when the SLEEP instruction is executed. To avoid the MCU entering the Sleep mode unless it is the programmers purpose, it is recommended to write the Sleep Enable (SE) bit to one just before the execution of the SLEEP instruction and to clear it immediately after waking up.

- **Bits 4..2 – SM2..0: Sleep Mode Select Bits 2, 1, and 0**

These bits select between the six available sleep modes as shown in [Table 17](#).

Table 17. Sleep Mode Select

| SM2 | SM1 | SM0 | Sleep Mode |
|-----|-----|-----|---------------------------------|
| 0 | 0 | 0 | Idle |
| 0 | 0 | 1 | ADC Noise Reduction |
| 0 | 1 | 0 | Power-down |
| 0 | 1 | 1 | Power-save |
| 1 | 0 | 0 | Reserved |
| 1 | 0 | 1 | Reserved |
| 1 | 1 | 0 | Standby ⁽¹⁾ |
| 1 | 1 | 1 | Extended Standby ⁽¹⁾ |

Note: 1. Standby mode and Extended Standby mode are only available with external crystals or resonators.

Idle Mode

When the SM2..0 bits are written to 000, the SLEEP instruction makes the MCU enter Idle mode, stopping the CPU but allowing SPI, USART, Analog Comparator, ADC, Two-wire Serial Interface, Timer/Counters, Watchdog, and the interrupt system to continue operating. This sleep mode basically halts clk_{CPU} and clk_{FLASH} , while allowing the other clocks to run.

Idle mode enables the MCU to wake up from external triggered interrupts as well as internal ones like the Timer Overflow and USART Transmit Complete interrupts. If wake-up from the Analog Comparator interrupt is not required, the Analog Comparator can be powered down by setting the ACD bit in the Analog Comparator Control and Status Register – ACSR. This will reduce power consumption in Idle mode. If the ADC is enabled, a conversion starts automatically when this mode is entered.

ADC Noise Reduction Mode

When the SM2..0 bits are written to 001, the SLEEP instruction makes the MCU enter ADC Noise Reduction mode, stopping the CPU but allowing the ADC, the External Interrupts, the Two-wire Serial Interface address watch, Timer/Counter0 and the Watchdog to continue operating (if enabled). This sleep mode basically halts $clk_{I/O}$, clk_{CPU} , and clk_{FLASH} , while allowing the other clocks to run.

This improves the noise environment for the ADC, enabling higher resolution measurements. If the ADC is enabled, a conversion starts automatically when this mode is entered. Apart from the ADC Conversion Complete interrupt, only an External Reset, a Watchdog Reset, a Brown-out Reset, a Two-wire Serial Interface address match interrupt, a Timer/Counter0 interrupt, an SPM/EEPROM ready interrupt, an External Level Interrupt on INT7:4, or an External Interrupt on INT3:0 can wake up the MCU from ADC Noise Reduction mode.

Power-down Mode

When the SM2..0 bits are written to 010, the SLEEP instruction makes the MCU enter Power-down mode. In this mode, the External Oscillator is stopped, while the External Interrupts, the Two-wire Serial Interface address watch, and the Watchdog continue operating (if enabled). Only an External Reset, a Watchdog Reset, a Brown-out Reset, a Two-wire Serial Interface address match interrupt, an External Level Interrupt on INT7:4, or an External Interrupt on INT3:0 can wake up the MCU. This sleep mode basically halts all generated clocks, allowing operation of asynchronous modules only.

Note that if a level triggered interrupt is used for wake-up from Power-down mode, the changed level must be held for some time to wake up the MCU. Refer to [“External Interrupts” on page 89](#) for details.

When waking up from Power-down mode, there is a delay from the wake-up condition occurs until the wake-up becomes effective. This allows the clock to restart and become stable after having been stopped. The wake-up period is defined by the same CKSEL fuses that define the Reset Time-out period, as described in [“Clock Sources” on page 36](#).

Power-save Mode

When the SM2..0 bits are written to 011, the SLEEP instruction makes the MCU enter Power-save mode. This mode is identical to Power-down, with one exception:

If Timer/Counter0 is clocked asynchronously, i.e., the AS0 bit in ASSR is set, Timer/Counter0 will run during sleep. The device can wake up from either Timer Overflow or Output Compare event from Timer/Counter0 if the corresponding Timer/Counter0 interrupt enable bits are set in TIMSK, and the global interrupt enable bit in SREG is set.

If the Asynchronous Timer is NOT clocked asynchronously, Power-down mode is recommended instead of Power-save mode because the contents of the registers in the asynchronous timer should be considered undefined after wake-up in Power-save mode if AS0 is 0.

This sleep mode basically halts all clocks except clk_{ASY} , allowing operation only of asynchronous modules, including Timer/Counter0 if clocked asynchronously.

Standby Mode

When the SM2..0 bits are 110 and an External Crystal/Resonator clock option is selected, the SLEEP instruction makes the MCU enter Standby mode. This mode is identical to Power-down with the exception that the Oscillator is kept running. From Standby mode, the device wakes up in 6 clock cycles.

Extended Standby Mode

When the SM2..0 bits are 111 and an external crystal/resonator clock option is selected, the SLEEP instruction makes the MCU enter Extended Standby mode. This mode is identical to Power-save mode with the exception that the Oscillator is kept running. From Extended Standby mode, the device wakes up in six clock cycles.

Table 18. Active Clock Domains and Wake Up Sources in the Different Sleep Modes

| Sleep Mode | Active Clock Domains | | | | | Oscillators | | Wake Up Sources | | | | | |
|---------------------------------|----------------------|----------------------|-------------------|--------------------|--------------------|---------------------------|-------------------|------------------|-------------------|------------------|------------------|-----|-----------|
| | clk _{CPU} | clk _{FLASH} | clk _{IO} | clk _{ADC} | clk _{ASY} | Main Clock Source Enabled | Timer Osc Enabled | INT7:0 | TWI Address Match | Timer 0 | SPM/EEPROM Ready | ADC | Other I/O |
| Idle | | | X | X | X | X | X ⁽²⁾ | X | X | X | X | X | X |
| ADC Noise Reduction | | | | X | X | X | X ⁽²⁾ | X ⁽³⁾ | X | X | X | X | |
| Power-down | | | | | | | | X ⁽³⁾ | X | | | | |
| Power-save | | | | | X ⁽²⁾ | | X ⁽²⁾ | X ⁽³⁾ | X | X ⁽²⁾ | | | |
| Standby ⁽¹⁾ | | | | | | X | | X ⁽³⁾ | X | | | | |
| Extended Standby ⁽¹⁾ | | | | | X ⁽²⁾ | X | X ⁽²⁾ | X ⁽³⁾ | X | X ⁽²⁾ | | | |

- Notes:
1. External Crystal or resonator selected as clock source
 2. If AS0 bit in ASSR is set
 3. Only INT3:0 or level interrupt INT7:4

Minimizing Power Consumption

There are several issues to consider when trying to minimize the power consumption in an AVR controlled system. In general, sleep modes should be used as much as possible, and the sleep mode should be selected so that as few as possible of the device's functions are operating. All functions not needed should be disabled. In particular, the following modules may need special consideration when trying to achieve the lowest possible power consumption. See also [“System Clock and Clock Options” on page 35](#).

Analog to Digital Converter

If enabled, the ADC will be enabled in all sleep modes. To save power, the ADC should be disabled before entering any sleep mode. When the ADC is turned off and on again, the next conversion will be an extended conversion. Refer to [“Analog to Digital Converter” on page 230](#) for details on ADC operation.

Analog Comparator

When entering Idle mode, the Analog Comparator should be disabled if not used. When entering ADC Noise Reduction mode, the Analog Comparator should be disabled. In the other sleep modes, the Analog Comparator is automatically disabled. However, if the Analog Comparator is set up to use the Internal Voltage Reference as input, the Analog Comparator should be disabled in all sleep modes. Otherwise, the Internal Voltage Reference will be enabled, independent of sleep mode. Refer to [“Analog Comparator” on page 227](#) for details on how to configure the Analog Comparator.

Brown-out Detector

If the Brown-out Detector is not needed in the application, this module should be turned off. If the Brown-out Detector is enabled by the BODEN fuse, it will be enabled in all sleep modes, and hence, always consume power. In the deeper sleep modes, this will contribute significantly to the total current consumption. Refer to [“Brown-out Detector” on page 47](#) for details on how to configure the Brown-out Detector.

Internal Voltage Reference

The Internal Voltage Reference will be enabled when needed by the Brown-out Detector, the Analog Comparator or the ADC. If these modules are disabled as described in the sections above, the internal voltage reference will be disabled and it will not be consuming power. When turned on again, the user must allow the reference to start up before the output is used. If the reference is kept on in sleep mode, the output can be used immediately. Refer to [“Internal Voltage Reference” on page 53](#) for details on the start-up time.

Watchdog Timer

If the Watchdog Timer is not needed in the application, this module should be turned off. If the Watchdog Timer is enabled, it will be enabled in all sleep modes, and hence, always consume power. In the deeper sleep modes, this will contribute significantly to the total current consumption. Refer to [“Watchdog Timer” on page 54](#) for details on how to configure the Watchdog Timer.

Port Pins

When entering a sleep mode, all port pins should be configured to use minimum power. The most important thing is then to ensure that no pins drive resistive loads. In sleep modes where the both the I/O clock ($clk_{I/O}$) and the ADC clock (clk_{ADC}) are stopped, the input buffers of the device will be disabled. This ensures that no power is consumed by the input logic when not needed. In some cases, the input logic is needed for detecting wake-up conditions, and it will then be enabled. Refer to the section [“Digital Input Enable and Sleep Modes” on page 69](#) for details on which pins are enabled. If the input buffer is enabled and the input signal is left floating or have an analog signal level close to $V_{CC}/2$, the input buffer will use excessive power.

JTAG Interface and On-chip Debug System

If the On-chip debug system is enabled by the OCDEN Fuse and the chip enters Power down or Power save sleep mode, the main clock source remains enabled. In these sleep modes, this will contribute significantly to the total current consumption. There are three alternative ways to avoid this:

- Disable OCDEN Fuse.
- Disable JTAGEN Fuse.
- Write one to the JTD bit in MCUCSR.

The TDO pin is left floating when the JTAG interface is enabled while the JTAG TAP controller is not shifting data. If the hardware connected to the TDO pin does not pull up the logic level, power consumption will increase. Note that the TDI pin for the next device in the scan chain contains a pull-up that avoids this problem. Writing the JTD bit in the MCUCSR register to one or leaving the JTAG fuse unprogrammed disables the JTAG interface.

System Control and Reset

Resetting the AVR

During Reset, all I/O registers are set to their initial values, and the program starts execution from the Reset Vector. The instruction placed at the Reset Vector must be a JMP – absolute jump – instruction to the reset handling routine. If the program never enables an interrupt source, the interrupt vectors are not used, and regular program code can be placed at these locations. This is also the case if the Reset Vector is in the Application section while the interrupt vectors are in the Boot section or vice versa. The circuit diagram in [Figure 22](#) shows the reset logic. [Table 19](#) defines the electrical parameters of the reset circuitry.

The I/O ports of the AVR are immediately reset to their initial state when a reset source goes active. This does not require any clock source to be running.

After all reset sources have gone inactive, a delay counter is invoked, stretching the internal reset. This allows the power to reach a stable level before normal operation starts. The time-out period of the delay counter is defined by the user through the CKSEL fuses. The different selections for the delay period are presented in [“Clock Sources” on page 36](#).

Reset Sources

The Atmel® AVR® ATmega128 has five sources of reset:

- Power-on Reset. The MCU is reset when the supply voltage is below the Power-on Reset threshold (V_{POT}).
- External Reset. The MCU is reset when a low level is present on the \overline{RESET} pin for longer than the minimum pulse length.
- Watchdog Reset. The MCU is reset when the Watchdog Timer period expires and the Watchdog is enabled.
- Brown-out Reset. The MCU is reset when the supply voltage V_{CC} is below the Brown-out Reset threshold (V_{BOT}) and the Brown-out Detector is enabled.
- JTAG AVR Reset. The MCU is reset as long as there is a logic one in the Reset Register, one of the scan chains of the JTAG system. Refer to the section [“IEEE 1149.1 \(JTAG\) Boundary-scan” on page 252](#) for details.

Figure 22. Reset Logic



Table 19. Reset Characteristics

| Symbol | Parameter | Condition | Min | Typ | Max | Units |
|-------------------|---|--------------|---------------------|-----|----------------------|-------|
| V _{POT} | Power-on Reset Threshold Voltage (rising) | | | 1.4 | 2.3 | V |
| | Power-on Reset Threshold Voltage (falling) ⁽¹⁾ | | | 1.3 | 2.3 | |
| V _{RST} | $\overline{\text{RESET}}$ Pin Threshold Voltage | | 0.2 V _{CC} | | 0.85 V _{CC} | |
| t _{RST} | Pulse width on $\overline{\text{RESET}}$ Pin | | 1.5 | | | μs |
| V _{BOT} | Brown-out Reset Threshold Voltage ⁽²⁾ | BODLEVEL = 1 | 2.4 | 2.6 | 2.9 | V |
| | | BODLEVEL = 0 | 3.7 | 4.0 | 4.5 | |
| t _{BOD} | Minimum low voltage period for Brown-out Detection | BODLEVEL = 1 | | 2 | | μs |
| | | BODLEVEL = 0 | | 2 | | |
| V _{HYST} | Brown-out Detector hysteresis | | | 100 | | mV |

Notes: 1. The Power-on Reset will not work unless the supply voltage has been below V_{POT} (falling)

2. V_{BOT} may be below nominal minimum operating voltage for some devices. For devices where this is the case, the device is tested down to $V_{CC} = V_{BOT}$ during the production test. This guarantees that a Brown-out Reset will occur before V_{CC} drops to a voltage where correct operation of the microcontroller is no longer guaranteed. The test is performed using $BODLEVEL=1$ for ATmega128L and $BODLEVEL=0$ for ATmega128. $BODLEVEL=1$ is not applicable for ATmega128

Power-on Reset

A Power-on Reset (POR) pulse is generated by an On-chip detection circuit. The detection level is defined in Table 19. The POR is activated whenever V_{CC} is below the detection level. The POR circuit can be used to trigger the Start-up Reset, as well as to detect a failure in supply voltage.

A Power-on Reset (POR) circuit ensures that the device is reset from Power-on. Reaching the Power-on Reset threshold voltage invokes the delay counter, which determines how long the device is kept in RESET after V_{CC} rise. The RESET signal is activated again, without any delay, when V_{CC} decreases below the detection level.

Figure 23. MCU Start-up, \overline{RESET} Tied to V_{CC} .



Figure 24. MCU Start-up, \overline{RESET} Extended Externally

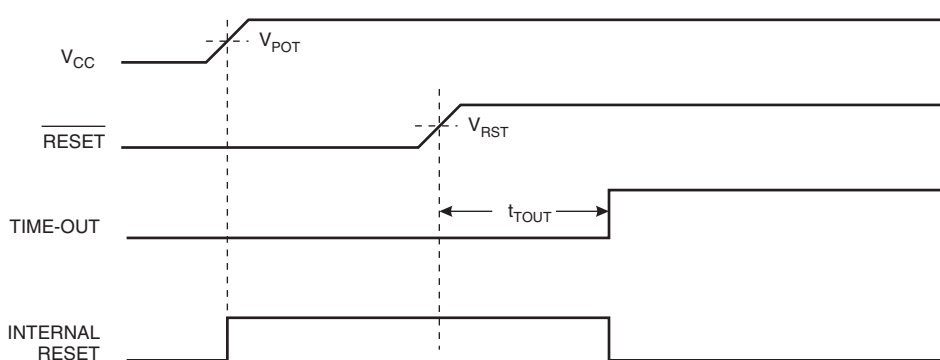

External Reset

An External Reset is generated by a low level on the \overline{RESET} pin. Reset pulses longer than the minimum pulse width (see Table 19) will generate a reset, even if the clock is not running. Shorter pulses are not guaranteed to generate a reset. When the applied signal reaches the Reset Threshold Voltage – V_{RST} on its positive edge, the delay counter starts the MCU after the Time-out period t_{TOUT} has expired.

Figure 25. External Reset During Operation

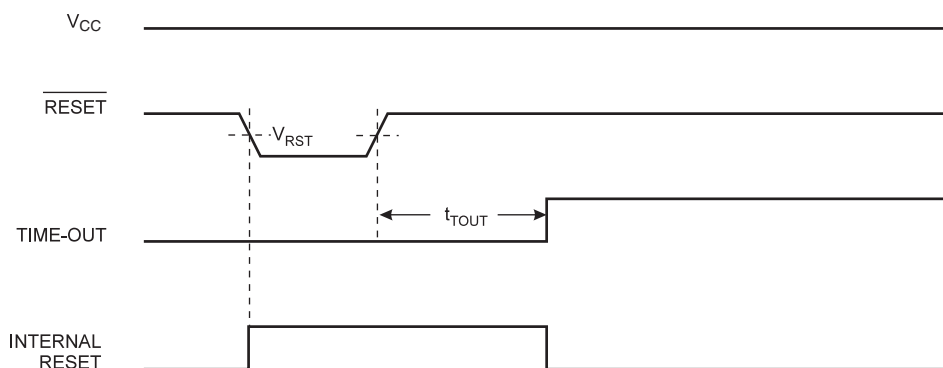

Brown-out Detection

ATmega128 has an On-chip Brown-out Detection (BOD) circuit for monitoring the V_{CC} level during operation by comparing it to a fixed trigger level. The trigger level for the BOD can be selected by the fuse BODLEVEL to be 2.7V (BODLEVEL unprogrammed), or 4.0V (BODLEVEL programmed). The trigger level has a hysteresis to ensure spike free Brown-out Detection. The hysteresis on the detection level should be interpreted as $V_{BOT+} = V_{BOT} + V_{HYST}/2$ and $V_{BOT-} = V_{BOT} - V_{HYST}/2$.

The BOD circuit can be enabled/disabled by the fuse BODEN. When the BOD is enabled (BODEN programmed), and V_{CC} decreases to a value below the trigger level (V_{BOT-} in Figure 26), the Brown-out Reset is immediately activated. When V_{CC} increases above the trigger level (V_{BOT+} in Figure 26), the delay counter starts the MCU after the time-out period t_{TOUT} has expired.

The BOD circuit will only detect a drop in V_{CC} if the voltage stays below the trigger level for longer than t_{BOD} given in Table 19.

Figure 26. Brown-out Reset During Operation

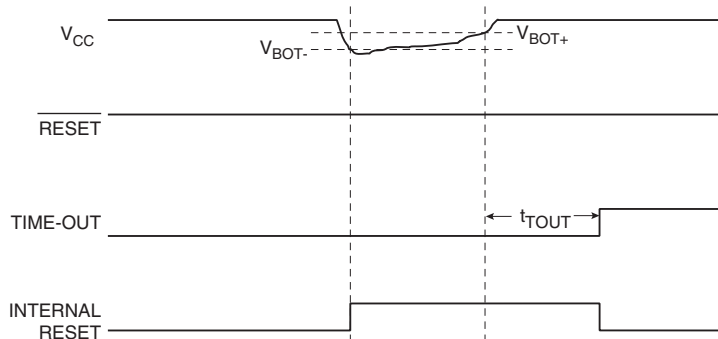

Watchdog Reset

When the Watchdog times out, it will generate a short reset pulse of 1 CK cycle duration. On the falling edge of this pulse, the delay timer starts counting the Time-out period t_{TOUT} . Refer to [page 54](#) for details on operation of the Watchdog Timer.

Figure 27. Watchdog Reset During Operation



MCU Control and Status Register – MCUCSR

The MCU Control and Status Register provides information on which reset source caused an MCU reset.

| Bit | 7 | 6 | 5 | 4 | 3 | 2 | 1 | 0 | |
|---------------|-----|---|---|---------------------|------|------|-------|------|--------|
| | JTD | – | – | JTRF | WDRF | BORF | EXTRF | PORF | MCUCSR |
| Read/Write | R/W | R | R | R/W | R/W | R/W | R/W | R/W | |
| Initial Value | 0 | 0 | 0 | See Bit Description | | | | | |

Note that only EXTRF and PORF are available in Atmel® AVR®ATmega103 compatibility mode.

- **Bit 4 – JTRF: JTAG Reset Flag**

This bit is set if a reset is being caused by a logic one in the JTAG Reset Register selected by the JTAG instruction AVR_RESET. This bit is reset by a Power-on Reset, or by writing a logic zero to the flag.

- **Bit 3 – WDRF: Watchdog Reset Flag**

This bit is set if a Watchdog Reset occurs. The bit is reset by a Power-on Reset, or by writing a logic zero to the flag.

- **Bit 2 – BORF: Brown-out Reset Flag**

This bit is set if a Brown-out Reset occurs. The bit is reset by a Power-on Reset, or by writing a logic zero to the flag.

- **Bit 1 – EXTRF: External Reset Flag**

This bit is set if an External Reset occurs. The bit is reset by a Power-on Reset, or by writing a logic zero to the flag.

- **Bit 0 – PORF: Power-On Reset Flag**

This bit is set if a Power-on Reset occurs. The bit is reset only by writing a logic zero to the flag.

To make use of the reset flags to identify a reset condition, the user should read and then reset the MCUCSR as early as possible in the program. If the register is cleared before another reset occurs, the source of the reset can be found by examining the reset flags.

Internal Voltage Reference

ATmega128 features an internal bandgap reference. This reference is used for Brown-out Detection, and it can be used as an input to the Analog Comparator or the ADC. The 2.56V reference to the ADC is generated from the internal bandgap reference.

Voltage Reference Enable Signals and Start-up Time

The voltage reference has a start-up time that may influence the way it should be used. The start-up time is given in [Table 20](#). To save power, the reference is not always turned on. The reference is on during the following situations:

1. When the BOD is enabled (by programming the BODEN fuse).
2. When the bandgap reference is connected to the Analog Comparator (by setting the ACBG bit in ACSR).
3. When the ADC is enabled.

Thus, when the BOD is not enabled, after setting the ACBG bit or enabling the ADC, the user must always allow the reference to start up before the output from the Analog Comparator or ADC is used. To reduce power consumption in Power-down mode, the user can avoid the three conditions above to ensure that the reference is turned off before entering Power-down mode.

Table 20. Internal Voltage Reference Characteristics

| Symbol | Parameter | Min | Typ | Max | Units |
|----------|---------------------------------------|------|------|------|---------|
| V_{BG} | Bandgap reference voltage | 1.15 | 1.23 | 1.40 | V |
| t_{BG} | Bandgap reference start-up time | | 40 | 70 | μ s |
| I_{BG} | Bandgap reference current consumption | | 10 | | μ A |

Watchdog Timer

The Watchdog Timer is clocked from a separate On-chip Oscillator which runs at 1MHz. This is the typical value at $V_{CC} = 5V$. See characterization data for typical values at other V_{CC} levels. By controlling the Watchdog Timer prescaler, the Watchdog Reset interval can be adjusted as shown in [Table 22 on page 56](#). The WDR – Watchdog Reset – instruction resets the Watchdog Timer. The Watchdog Timer is also reset when it is disabled and when a Chip Reset occurs. Eight different clock cycle periods can be selected to determine the reset period. If the reset period expires without another Watchdog Reset, the ATmega128 resets and executes from the Reset Vector. For timing details on the Watchdog Reset, refer to [page 53](#).

To prevent unintentional disabling of the Watchdog or unintentional change of time-out period, 3 different safety levels are selected by the Fuses M103C and WDTON as shown in [Table 21](#). Safety level 0 corresponds to the setting in ATmega103. There is no restriction on enabling the WDT in any of the safety levels. Refer to [“Timed Sequences for Changing the Configuration of the Watchdog Timer” on page 57](#) for details.

Table 21. WDT Configuration as a Function of the Fuse Settings of M103C and WDTON.

| M103C | WDTON | Safety Level | WDT Initial State | How to Disable the WDT | How to Change Time-out |
|--------------|--------------|--------------|-------------------|------------------------|------------------------|
| Unprogrammed | Unprogrammed | 1 | Disabled | Timed sequence | Timed sequence |
| Unprogrammed | Programmed | 2 | Enabled | Always enabled | Timed sequence |
| Programmed | Unprogrammed | 0 | Disabled | Timed sequence | No restriction |
| Programmed | Programmed | 2 | Enabled | Always enabled | Timed sequence |

Figure 28. Watchdog Timer

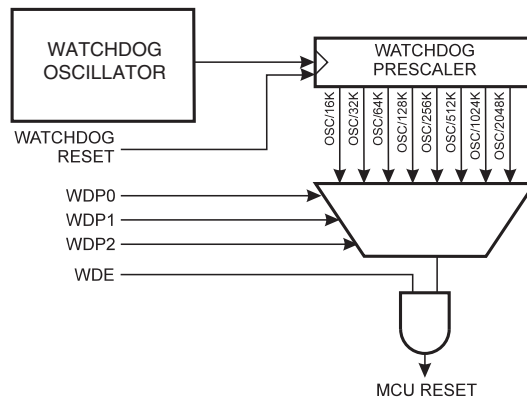

Watchdog Timer Control Register – WDTCR

| Bit | 7 | 6 | 5 | 4 | 3 | 2 | 1 | 0 | |
|---------------|---|---|---|------|-----|------|------|------|-------|
| | – | – | – | WDCE | WDE | WDP2 | WDP1 | WDP0 | WDTCR |
| Read/Write | R | R | R | R/W | R/W | R/W | R/W | R/W | |
| Initial Value | 0 | 0 | 0 | 0 | 0 | 0 | 0 | 0 | |

- **Bits 7..5 – Res: Reserved Bits**

These bits are reserved bits in the ATmega128 and will always read as zero.

- **Bit 4 – WDCE: Watchdog Change Enable**

This bit must be set when the WDE bit is written to logic zero. Otherwise, the Watchdog will not be disabled. Once written to one, hardware will clear this bit after four clock cycles. Refer to the description of the WDE bit for a Watchdog disable procedure. In Safety Level 1 and 2, this bit must also be set when changing the prescaler bits. See [“Timed Sequences for Changing the Configuration of the Watchdog Timer” on page 57.](#)

- **Bit 3 – WDE: Watchdog Enable**

When the WDE is written to logic one, the Watchdog Timer is enabled, and if the WDE is written to logic zero, the Watchdog Timer function is disabled. WDE can only be cleared if the WDCE bit has logic level one. To disable an enabled Watchdog Timer, the following procedure must be followed:

1. In the same operation, write a logic one to WDCE and WDE. A logic one must be written to WDE even though it is set to one before the disable operation starts.
2. Within the next four clock cycles, write a logic 0 to WDE. This disables the Watchdog.

In safety level 2, it is not possible to disable the Watchdog Timer, even with the algorithm described above. See [“Timed Sequences for Changing the Configuration of the Watchdog Timer” on page 57.](#)

- **Bits 2..0 – WDP2, WDP1, WDP0: Watchdog Timer Prescaler 2, 1, and 0**

The WDP2, WDP1, and WDP0 bits determine the Watchdog Timer prescaling when the Watchdog Timer is enabled. The different prescaling values and their corresponding Timeout Periods are shown in [Table 22.](#)

Table 22. Watchdog Timer Prescale Select

| WDP2 | WDP1 | WDP0 | Number of WDT Oscillator Cycles | Typical Time-out at V _{CC} = 3.0V | Typical Time-out at V _{CC} = 5.0V |
|------|------|------|---------------------------------|--|--|
| 0 | 0 | 0 | 16K (16,384) | 14.8ms | 14.0ms |
| 0 | 0 | 1 | 32K (32,768) | 29.6ms | 28.1ms |
| 0 | 1 | 0 | 64K (65,536) | 59.1ms | 56.2ms |
| 0 | 1 | 1 | 128K (131,072) | 0.12s | 0.11s |
| 1 | 0 | 0 | 256K (262,144) | 0.24s | 0.22s |
| 1 | 0 | 1 | 512K (524,288) | 0.47s | 0.45s |
| 1 | 1 | 0 | 1,024K (1,048,576) | 0.95s | 0.9s |
| 1 | 1 | 1 | 2,048K (2,097,152) | 1.9s | 1.8s |

The following code example shows one assembly and one C function for turning off the WDT. The example assumes that interrupts are controlled (e.g. by disabling interrupts globally) so that no interrupts will occur during execution of these functions.

| Assembly Code Example |
|--|
| <pre> WDT_off: ; Reset WDT wdr in r16, WDTCR ; Write logical one to WDCE and WDE ori r16, (1<<WDCE) (1<<WDE) out WDTCR, r16 ; Turn off WDT ldi r16, (0<<WDE) out WDTCR, r16 ret </pre> |
| C Code Example |
| <pre> void WDT_off(void) { /* Reset WDT*/ __watchdog_reset(); /* Write logical one to WDCE and WDE */ WDTCR = (1<<WDCE) (1<<WDE); /* Turn off WDT */ WDTCR = 0x00; } </pre> |

Timed Sequences for Changing the Configuration of the Watchdog Timer

The sequence for changing configuration differs slightly between the three safety levels. Separate procedures are described for each level.

Safety Level 0

This mode is compatible with the Watchdog operation found in ATmega103. The Watchdog Timer is initially disabled, but can be enabled by writing the WDE bit to 1 without any restriction. The time-out period can be changed at any time without restriction. To disable an enabled Watchdog Timer, the procedure described on [page 55](#) (WDE bit description) must be followed.

Safety Level 1

In this mode, the Watchdog Timer is initially disabled, but can be enabled by writing the WDE bit to 1 without any restriction. A timed sequence is needed when changing the Watchdog Time-out period or disabling an enabled Watchdog Timer. To disable an enabled Watchdog Timer, and/or changing the Watchdog Time-out, the following procedure must be followed:

1. In the same operation, write a logic one to WDCE and WDE. A logic one must be written to WDE regardless of the previous value of the WDE bit.
2. Within the next four clock cycles, in the same operation, write the WDE and WDP bits as desired, but with the WDCE bit cleared.

Safety Level 2

In this mode, the Watchdog Timer is always enabled, and the WDE bit will always read as one. A timed sequence is needed when changing the Watchdog Time-out period. To change the Watchdog Time-out, the following procedure must be followed:

1. In the same operation, write a logical one to WDCE and WDE. Even though the WDE always is set, the WDE must be written to one to start the timed sequence.
2. Within the next four clock cycles, in the same operation, write the WDP bits as desired, but with the WDCE bit cleared. The value written to the WDE bit is irrelevant.

Interrupts

This section describes the specifics of the interrupt handling as performed in Atmel® AVR® ATmega128. For a general explanation of the AVR interrupt handling, refer to “Reset and Interrupt Handling” on page 14.

Interrupt Vectors in ATmega128

Table 23. Reset and Interrupt Vectors

| Vector No. | Program Address ⁽²⁾ | Source | Interrupt Definition |
|------------|--------------------------------|--------------|---|
| 1 | \$0000 ⁽¹⁾ | RESET | External Pin, Power-on Reset, Brown-out Reset, Watchdog Reset, and JTAG AVR Reset |
| 2 | \$0002 | INT0 | External Interrupt Request 0 |
| 3 | \$0004 | INT1 | External Interrupt Request 1 |
| 4 | \$0006 | INT2 | External Interrupt Request 2 |
| 5 | \$0008 | INT3 | External Interrupt Request 3 |
| 6 | \$000A | INT4 | External Interrupt Request 4 |
| 7 | \$000C | INT5 | External Interrupt Request 5 |
| 8 | \$000E | INT6 | External Interrupt Request 6 |
| 9 | \$0010 | INT7 | External Interrupt Request 7 |
| 10 | \$0012 | TIMER2 COMP | Timer/Counter2 Compare Match |
| 11 | \$0014 | TIMER2 OVF | Timer/Counter2 Overflow |
| 12 | \$0016 | TIMER1 CAPT | Timer/Counter1 Capture Event |
| 13 | \$0018 | TIMER1 COMPA | Timer/Counter1 Compare Match A |
| 14 | \$001A | TIMER1 COMPB | Timer/Counter1 Compare Match B |
| 15 | \$001C | TIMER1 OVF | Timer/Counter1 Overflow |
| 16 | \$001E | TIMER0 COMP | Timer/Counter0 Compare Match |
| 17 | \$0020 | TIMER0 OVF | Timer/Counter0 Overflow |
| 18 | \$0022 | SPI, STC | SPI Serial Transfer Complete |
| 19 | \$0024 | USART0, RX | USART0, Rx Complete |
| 20 | \$0026 | USART0, UDRE | USART0 Data Register Empty |
| 21 | \$0028 | USART0, TX | USART0, Tx Complete |
| 22 | \$002A | ADC | ADC Conversion Complete |
| 23 | \$002C | EE READY | EEPROM Ready |
| 24 | \$002E | ANALOG COMP | Analog Comparator |
| 25 | \$0030 ⁽³⁾ | TIMER1 COMPC | Timer/Counter1 Compare Match C |
| 26 | \$0032 ⁽³⁾ | TIMER3 CAPT | Timer/Counter3 Capture Event |
| 27 | \$0034 ⁽³⁾ | TIMER3 COMPA | Timer/Counter3 Compare Match A |
| 28 | \$0036 ⁽³⁾ | TIMER3 COMPB | Timer/Counter3 Compare Match B |
| 29 | \$0038 ⁽³⁾ | TIMER3 COMPC | Timer/Counter3 Compare Match C |
| 30 | \$003A ⁽³⁾ | TIMER3 OVF | Timer/Counter3 Overflow |

Table 23. Reset and Interrupt Vectors

| Vector No. | Program Address ⁽²⁾ | Source | Interrupt Definition |
|------------|--------------------------------|--------------|----------------------------|
| 31 | \$003C ⁽³⁾ | USART1, RX | USART1, Rx Complete |
| 32 | \$003E ⁽³⁾ | USART1, UDRE | USART1 Data Register Empty |
| 33 | \$0040 ⁽³⁾ | USART1, TX | USART1, Tx Complete |
| 34 | \$0042 ⁽³⁾ | TWI | Two-wire Serial Interface |
| 35 | \$0044 ⁽³⁾ | SPM READY | Store Program Memory Ready |

- Notes:
1. When the BOTRST fuse is programmed, the device will jump to the Boot Loader address at reset, see [“Boot Loader Support – Read-While-Write Self-Programming” on page 273](#).
 2. When the IVSEL bit in MCUCR is set, interrupt vectors will be moved to the start of the Boot Flash section. The address of each interrupt vector will then be address in this table added to the start address of the boot Flash section.
 3. The Interrupts on address \$0030 - \$0044 do not exist in ATmega103 compatibility mode.

[Table 24](#) shows Reset and interrupt vectors placement for the various combinations of BOTRST and IVSEL settings. If the program never enables an interrupt source, the interrupt vectors are not used, and regular program code can be placed at these locations. This is also the case if the Reset Vector is in the Application section while the interrupt vectors are in the Boot section or vice versa.

Table 24. Reset and Interrupt Vectors Placement

| BOTRST | IVSEL | Reset Address | Interrupt Vectors Start Address |
|--------|-------|--------------------|---------------------------------|
| 1 | 0 | \$0000 | \$0002 |
| 1 | 1 | \$0000 | Boot Reset Address + \$0002 |
| 0 | 0 | Boot Reset Address | \$0002 |
| 0 | 1 | Boot Reset Address | Boot Reset Address + \$0002 |

- Note: The Boot Reset Address is shown in [Table 112 on page 284](#). For the BOTRST fuse “1” means unprogrammed while “0” means programmed.

The most typical and general program setup for the Reset and Interrupt Vector Addresses in ATmega128 is:

| Address | Labels | Code | Comments |
|---------|---------|----------------------------|---|
| \$0000 | jmp | RESET | ; Reset Handler |
| \$0002 | jmp | EXT_INT0 | ; IRQ0 Handler |
| \$0004 | jmp | EXT_INT1 | ; IRQ1 Handler |
| \$0006 | jmp | EXT_INT2 | ; IRQ2 Handler |
| \$0008 | jmp | EXT_INT3 | ; IRQ3 Handler |
| \$000A | jmp | EXT_INT4 | ; IRQ4 Handler |
| \$000C | jmp | EXT_INT5 | ; IRQ5 Handler |
| \$000E | jmp | EXT_INT6 | ; IRQ6 Handler |
| \$0010 | jmp | EXT_INT7 | ; IRQ7 Handler |
| \$0012 | jmp | TIM2_COMP | ; Timer2 Compare Handler |
| \$0014 | jmp | TIM2_OVF | ; Timer2 Overflow Handler |
| \$0016 | jmp | TIM1_CAPT | ; Timer1 Capture Handler |
| \$0018 | jmp | TIM1_COMPA | ; Timer1 CompareA Handler |
| \$001A | jmp | TIM1_COMPB | ; Timer1 CompareB Handler |
| \$001C | jmp | TIM1_OVF | ; Timer1 Overflow Handler |
| \$001E | jmp | TIM0_COMP | ; Timer0 Compare Handler |
| \$0020 | jmp | TIM0_OVF | ; Timer0 Overflow Handler |
| \$0022 | jmp | SPI_STC | ; SPI Transfer Complete Handler |
| \$0024 | jmp | USART0_RXC | ; USART0 RX Complete Handler |
| \$0026 | jmp | USART0_DRE | ; USART0,UDR Empty Handler |
| \$0028 | jmp | USART0_TXC | ; USART0 TX Complete Handler |
| \$002A | jmp | ADC | ; ADC Conversion Complete Handler |
| \$002C | jmp | EE_RDY | ; EEPROM Ready Handler |
| \$002E | jmp | ANA_COMP | ; Analog Comparator Handler |
| \$0030 | jmp | TIM1_COMPC | ; Timer1 CompareC Handler |
| \$0032 | jmp | TIM3_CAPT | ; Timer3 Capture Handler |
| \$0034 | jmp | TIM3_COMPA | ; Timer3 CompareA Handler |
| \$0036 | jmp | TIM3_COMPB | ; Timer3 CompareB Handler |
| \$0038 | jmp | TIM3_COMPC | ; Timer3 CompareC Handler |
| \$003A | jmp | TIM3_OVF | ; Timer3 Overflow Handler |
| \$003C | jmp | USART1_RXC | ; USART1 RX Complete Handler |
| \$003E | jmp | USART1_DRE | ; USART1,UDR Empty Handler |
| \$0040 | jmp | USART1_TXC | ; USART1 TX Complete Handler |
| \$0042 | jmp | TWI | ; Two-wire Serial Interface Interrupt Handler |
| \$0044 | jmp | SPM_RDY | ; SPM Ready Handler |
| | | | ; |
| \$0046 | | RESET:ldir16, high(RAMEND) | ; Main program start |
| \$0047 | out | SPH,r16 | ; Set stack pointer to top of RAM |
| \$0048 | ldi | r16, low(RAMEND) | |
| \$0049 | out | SPL,r16 | |
| \$004A | sei | | ; Enable interrupts |
| \$004B | <instr> | xxx | |
| ... | ... | ... | ... |

When the BOOTRST fuse is unprogrammed, the Boot section size set to 8Kbytes and the IVSEL bit in the MCUCR Register is set before any interrupts are enabled, the most typical and general program setup for the Reset and Interrupt Vector Addresses is:

```

Address  LabelsCode          Comments
$0000   RESET:ldi   r16,high(RAMEND); Main program start
$0001           out   SPH,r16   ; Set stack pointer to top of RAM
$0002           ldi   r16,low(RAMEND)
$0003           out   SPL,r16
$0004           sei                   ; Enable interrupts
$0005           <instr> xxx
;
.org $F002
$F002           jmp   EXT_INT0   ; IRQ0 Handler
$F004           jmp   EXT_INT1   ; IRQ1 Handler
...           ...   ...   ;
$F044           jmp   SPM_RDY    ; Store Program Memory Ready Handler

```

When the BOOTRST fuse is programmed and the Boot section size set to 8Kbytes, the most typical and general program setup for the Reset and Interrupt Vector Addresses is:

```

Address  LabelsCode          Comments
.org $0002
$0002           jmp   EXT_INT0   ; IRQ0 Handler
$0004           jmp   EXT_INT1   ; IRQ1 Handler
...           ...   ...   ;
$0044           jmp   SPM_RDY    ; Store Program Memory Ready Handler
;
.org $F000
$F000   RESET: ldi   r16,high(RAMEND); Main program start
$F001           out   SPH,r16   ; Set stack pointer to top of RAM
$F002           ldi   r16,low(RAMEND)
$F003           out   SPL,r16
$F004           sei                   ; Enable interrupts
$F005           <instr> xxx

```

When the BOOTRST fuse is programmed, the Boot section size set to 8Kbytes and the IVSEL bit in the MCUCR Register is set before any interrupts are enabled, the most typical and general program setup for the Reset and Interrupt Vector Addresses is:

```

Address          Labels  Code          Comments
;
.org $F000
$F000           jmp   RESET      ; Reset handler
$F002           jmp   EXT_INT0   ; IRQ0 Handler
$F004           jmp   EXT_INT1   ; IRQ1 Handler
...           ...   ...   ;
$F044           jmp   SPM_RDY    ; Store Program Memory Ready Handler
$F046   RESET: ldi   r16,high(RAMEND); Main program start
$F047           out   SPH,r16   ; Set stack pointer to top of RAM
$F048           ldi   r16,low(RAMEND)

```

```

$F049      out    SPL,r16
$F04A      sei                      ; Enable interrupts
$F04B      <instr> xxx
    
```

Moving Interrupts Between Application and Boot Space

The General Interrupt Control Register controls the placement of the interrupt vector table.

MCU Control Register – MCUCR

| Bit | 7 | 6 | 5 | 4 | 3 | 2 | 1 | 0 | |
|---------------|-----|-------|-----|-----|-----|-----|-------|------|-------|
| | SRE | SRW10 | SE | SM1 | SM0 | SM2 | IVSEL | IVCE | MCUCR |
| Read/Write | R/W | R/W | R/W | R/W | R/W | R/W | R/W | R/W | |
| Initial Value | 0 | 0 | 0 | 0 | 0 | 0 | 0 | 0 | |

• Bit 1 – IVSEL: Interrupt Vector Select

When the IVSEL bit is cleared (zero), the interrupt vectors are placed at the start of the Flash memory. When this bit is set (one), the interrupt vectors are moved to the beginning of the Boot Loader section of the flash. The actual address of the start of the Boot Flash section is determined by the BOOTSZ fuses. Refer to the section [“Boot Loader Support – Read-While-Write Self-Programming” on page 273](#) for details. To avoid unintentional changes of interrupt vector tables, a special write procedure must be followed to change the IVSEL bit:

1. Write the Interrupt Vector Change Enable (IVCE) bit to one.
2. Within four cycles, write the desired value to IVSEL while writing a zero to IVCE.

Interrupts will automatically be disabled while this sequence is executed. Interrupts are disabled in the cycle IVCE is set, and they remain disabled until after the instruction following the write to IVSEL. If IVSEL is not written, interrupts remain disabled for four cycles. The I-bit in the Status Register is unaffected by the automatic disabling.

Note: If interrupt vectors are placed in the Boot Loader section and Boot Lock bit BLB02 is programmed, interrupts are disabled while executing from the Application section. If interrupt vectors are placed in the Application section and Boot Lock bit BLB12 is programmed, interrupts are disabled while executing from the Boot Loader section. Refer to the section [“Boot Loader Support – Read-While-Write Self-Programming” on page 273](#) for details on Boot Lock bits.

- **Bit 0 – IVCE: Interrupt Vector Change Enable**

The IVCE bit must be written to logic one to enable change of the IVSEL bit. IVCE is cleared by hardware four cycles after it is written or when IVSEL is written. Setting the IVCE bit will disable interrupts, as explained in the IVSEL description above. See Code Example below.

| Assembly Code Example |
|---|
| <pre>Move_interrupts: ; Enable change of interrupt vectors ldi r16, (1<<IVCE) out MCUCR, r16 ; Move interrupts to boot flash section ldi r16, (1<<IVSEL) out MCUCR, r16 ret</pre> |
| C Code Example |
| <pre>void Move_interrupts(void) { /* Enable change of interrupt vectors */ MCUCR = (1<<IVCE); /* Move interrupts to boot flash section */ MCUCR = (1<<IVSEL); }</pre> |

I/O Ports

Introduction

All Atmel® AVR® ports have true Read-Modify-Write functionality when used as general digital I/O ports. This means that the direction of one port pin can be changed without unintentionally changing the direction of any other pin with the SBI and CBI instructions. The same applies when changing drive value (if configured as output) or enabling/disabling of pull-up resistors (if configured as input). Each output buffer has symmetrical drive characteristics with both high sink and source capability. The pin driver is strong enough to drive LED displays directly. All port pins have individually selectable pull-up resistors with a supply-voltage invariant resistance. All I/O pins have protection diodes to both V_{CC} and Ground as indicated in Figure 29. Refer to “[Electrical Characteristics](#)” on page 318 for a complete list of parameters.

Figure 29. I/O Pin Equivalent Schematic



All registers and bit references in this section are written in general form. A lower case “x” represents the numbering letter for the port, and a lower case “n” represents the bit number. However, when using the register or bit defines in a program, the precise form must be used. For example, PORTB3 for bit no. 3 in Port B, here documented generally as PORTxn. The physical I/O registers and bit locations are listed in “[Register Description for I/O Ports](#)” on page 86.

Three I/O memory address locations are allocated for each port, one each for the Data Register – PORTx, Data Direction Register – DDRx, and the Port Input Pins – PINx. The Port Input Pins I/O location is read only, while the Data Register and the Data Direction Register are read/write. In addition, the Pull-up Disable – PUD bit in SFIOR disables the pull-up function for all pins in all ports when set.

Using the I/O port as General Digital I/O is described in “[Ports as General Digital I/O](#)” on page 66. Most port pins are multiplexed with alternate functions for the peripheral features on the device. How each alternate function interferes with the port pin is described in “[Alternate Port Functions](#)” on page 70. Refer to the individual module sections for a full description of the alternate functions.

Note that enabling the alternate function of some of the port pins does not affect the use of the other pins in the port as General Digital I/O.

Ports as General Digital I/O

The ports are bi-directional I/O ports with optional internal pull-ups. Figure 30 shows a functional description of one I/O port pin, here generically called P_{xn}.

Figure 30. General Digital I/O⁽¹⁾



Note: 1. WP_x, WD_x, RR_x, RP_x, and RD_x are common to all pins within the same port. clk_{I/O}, SLEEP, and PUD are common to all ports.

Configuring the Pin

Each port pin consists of three Register bits: DD_{xn}, PORT_{xn}, and PIN_{xn}. As shown in “[Register Description for I/O Ports](#)” on page 86, the DD_{xn} bits are accessed at the DDR_x I/O address, the PORT_{xn} bits at the PORT_x I/O address, and the PIN_{xn} bits at the PIN_x I/O address.

The DD_{xn} bit in the DDR_x Register selects the direction of this pin. If DD_{xn} is written logic one, P_{xn} is configured as an output pin. If DD_{xn} is written logic zero, P_{xn} is configured as an input pin.

If PORT_{xn} is written logic one when the pin is configured as an input pin, the pull-up resistor is activated. To switch the pull-up resistor off, PORT_{xn} has to be written logic zero or the pin has to be configured as an output pin. The port pins are tri-stated when a Reset condition becomes active, even if no clocks are running.

If PORT_{xn} is written logic one when the pin is configured as an output pin, the port pin is driven high (one). If PORT_{xn} is written logic zero when the pin is configured as an output pin, the port pin is driven low (zero).

When switching between tri-state ({DD_{xn}, PORT_{xn}} = 0b00) and output high ({DD_{xn}, PORT_{xn}} = 0b11), an intermediate state with either pull-up enabled ({DD_{xn}, PORT_{xn}} = 0b01) or output

low ($\{DDxn, PORTxn\} = 0b10$) must occur. Normally, the pull-up enabled state is fully acceptable, as a high-impedant environment will not notice the difference between a strong high driver and a pull-up. If this is not the case, the PUD bit in the SFIOR Register can be written to one to disable all pull-ups in all ports.

Switching between input with pull-up and output low generates the same problem. The user must use either the tri-state ($\{DDxn, PORTxn\} = 0b00$) or the output high state ($\{DDxn, PORTxn\} = 0b11$) as an intermediate step.

Table 25 summarizes the control signals for the pin value.

Table 25. Port Pin Configurations

| DDxn | PORTxn | PUD (in SFIOR) | I/O | Pull-up | Comment |
|------|--------|----------------|--------|---------|---|
| 0 | 0 | X | Input | No | Tri-state (Hi-Z) |
| 0 | 1 | 0 | Input | Yes | Pxn will source current if ext. pulled low. |
| 0 | 1 | 1 | Input | No | Tri-state (Hi-Z) |
| 1 | 0 | X | Output | No | Output Low (Sink) |
| 1 | 1 | X | Output | No | Output High (Source) |

Reading the Pin Value

Independent of the setting of Data Direction bit DDxn, the port pin can be read through the PINxn Register bit. As shown in Figure 30, the PINxn Register bit and the preceding latch constitute a synchronizer. This is needed to avoid metastability if the physical pin changes value near the edge of the internal clock, but it also introduces a delay. Figure 31 shows a timing diagram of the synchronization when reading an externally applied pin value. The maximum and minimum propagation delays are denoted $t_{pd,max}$ and $t_{pd,min}$ respectively.

Figure 31. Synchronization when Reading an Externally Applied Pin Value



Consider the clock period starting shortly *after* the first falling edge of the system clock. The latch is closed when the clock is low, and goes transparent when the clock is high, as indicated by the

shaded region of the “SYNC LATCH” signal. The signal value is latched when the system clock goes low. It is clocked into the PINxn Register at the succeeding positive clock edge. As indicated by the two arrows $t_{pd,max}$ and $t_{pd,min}$, a single signal transition on the pin will be delayed between $\frac{1}{2}$ and $1\frac{1}{2}$ system clock period depending upon the time of assertion.

When reading back a software assigned pin value, a *nop* instruction must be inserted as indicated in Figure 32. The *out* instruction sets the “SYNC LATCH” signal at the positive edge of the clock. In this case, the delay t_{pd} through the synchronizer is one system clock period.

Figure 32. Synchronization when Reading a Software Assigned Pin Value

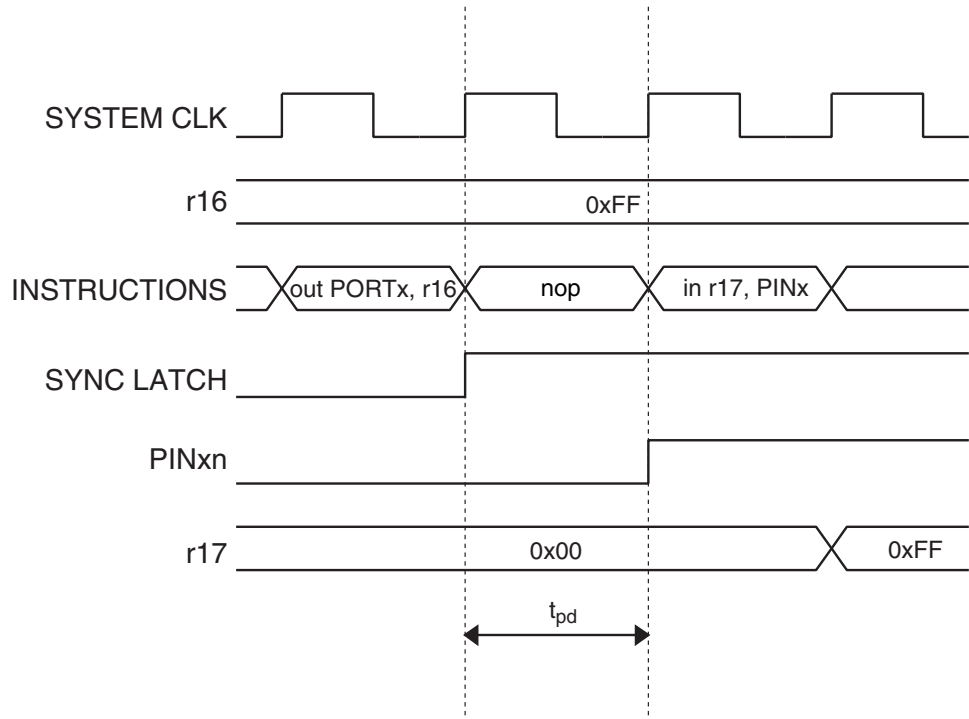

The following code example shows how to set port B pins 0 and 1 high, 2 and 3 low, and define the port pins from 4 to 7 as input with pull-ups assigned to port pins 6 and 7. The resulting pin values are read back again, but as previously discussed, a *nop* instruction is included to be able to read back the value recently assigned to some of the pins.

Assembly Code Example⁽¹⁾

```

...
; Define pull-ups and set outputs high
; Define directions for port pins
ldi r16, (1<<PB7) | (1<<PB6) | (1<<PB1) | (1<<PB0)
ldi r17, (1<<DDB3) | (1<<DDB2) | (1<<DDB1) | (1<<DDB0)
out PORTB, r16
out DDRB, r17
; Insert nop for synchronization
nop
; Read port pins
in r16, PINB
...

```

C Code Example⁽¹⁾

```

unsigned char i;
...
/* Define pull-ups and set outputs high */
/* Define directions for port pins */
PORTB = (1<<PB7) | (1<<PB6) | (1<<PB1) | (1<<PB0);
DDRB = (1<<DDB3) | (1<<DDB2) | (1<<DDB1) | (1<<DDB0);
/* Insert nop for synchronization*/
__no_operation();
/* Read port pins */
i = PINB;
...

```

Note: 1. For the assembly program, two temporary registers are used to minimize the time from pull-ups are set on pins 0, 1, 6, and 7, until the direction bits are correctly set, defining bit 2 and 3 as low and redefining bits 0 and 1 as strong high drivers.

Digital Input Enable and Sleep Modes

As shown in [Figure 30](#), the digital input signal can be clamped to ground at the input of the schmitt-trigger. The signal denoted SLEEP in the figure, is set by the MCU Sleep Controller in Power-down mode, Power-save mode, Standby mode, and Extended Standby mode to avoid high power consumption if some input signals are left floating, or have an analog signal level close to $V_{CC}/2$.

SLEEP is overridden for port pins enabled as External Interrupt pins. If the External Interrupt Request is not enabled, SLEEP is active also for these pins. SLEEP is also overridden by various other alternate functions as described in [“Alternate Port Functions” on page 70](#).

If a logic high level (“one”) is present on an Asynchronous External Interrupt pin configured as “Interrupt on Rising Edge, Falling Edge, or Any Logic Change on Pin” while the external interrupt is *not* enabled, the corresponding External Interrupt Flag will be set when resuming from the above mentioned sleep modes, as the clamping in these sleep modes produces the requested logic change.

Unconnected pins

If some pins are unused, it is recommended to ensure that these pins have a defined level. Even though most of the digital inputs are disabled in the deep sleep modes as described above, floating inputs should be avoided to reduce current consumption in all other modes where the digital inputs are enabled (Reset, Active mode and Idle mode).

The simplest method to ensure a defined level of an unused pin, is to enable the internal pull-up. In this case, the pull-up will be disabled during reset. If low power consumption during reset is important, it is recommended to use an external pull-up or pull-down. Connecting unused pins directly to V_{CC} or GND is not recommended, since this may cause excessive currents if the pin is accidentally configured as an output.

Alternate Port Functions

Most port pins have alternate functions in addition to being general digital I/Os. Figure 33 shows how the port pin control signals from the simplified Figure 30 can be overridden by alternate functions. The overriding signals may not be present in all port pins, but the figure serves as a generic description applicable to all port pins in the AVR microcontroller family.

Figure 33. Alternate Port Functions⁽¹⁾



Note: 1. WPx, WDx, RLx, RPx, and RDx are common to all pins within the same port. clk_{I/O}, SLEEP, and PUD are common to all ports. All other signals are unique for each pin.

Table 26 summarizes the function of the overriding signals. The pin and port indexes from Figure 33 are not shown in the succeeding tables. The overriding signals are generated internally in the modules having the alternate function.

Table 26. Generic Description of Overriding Signals for Alternate Functions.

| Signal Name | Full Name | Description |
|-------------|--------------------------------------|--|
| PUOE | Pull-up Override Enable | If this signal is set, the pull-up enable is controlled by the PUOV signal. If this signal is cleared, the pull-up is enabled when {DDxn, PORTxn, PUD} = 0b010. |
| PUOV | Pull-up Override Value | If PUOE is set, the pull-up is enabled/disabled when PUOV is set/cleared, regardless of the setting of the DDxn, PORTxn, and PUD Register bits. |
| DDOE | Data Direction Override Enable | If this signal is set, the Output Driver Enable is controlled by the DDOV signal. If this signal is cleared, the Output driver is enabled by the DDxn Register bit. |
| DDOV | Data Direction Override Value | If DDOE is set, the Output Driver is enabled/disabled when DDOV is set/cleared, regardless of the setting of the DDxn Register bit. |
| PVOE | Port Value Override Enable | If this signal is set and the Output Driver is enabled, the port value is controlled by the PVOV signal. If PVOE is cleared, and the Output Driver is enabled, the port Value is controlled by the PORTxn Register bit. |
| PVOV | Port Value Override Value | If PVOE is set, the port value is set to PVOV, regardless of the setting of the PORTxn Register bit. |
| DIEOE | Digital Input Enable Override Enable | If this bit is set, the Digital Input Enable is controlled by the DIEOV signal. If this signal is cleared, the Digital Input Enable is determined by MCU-state (Normal mode, Sleep modes). |
| DIEOV | Digital Input Enable Override Value | If DIEOE is set, the Digital Input is enabled/disabled when DIEOV is set/cleared, regardless of the MCU state (Normal mode, Sleep modes). |
| DI | Digital Input | This is the Digital Input to alternate functions. In the figure, the signal is connected to the output of the schmitt trigger but before the synchronizer. Unless the Digital Input is used as a clock source, the module with the alternate function will use its own synchronizer. |
| AIO | Analog Input/output | This is the Analog Input/output to/from alternate functions. The signal is connected directly to the pad, and can be used bi-directionally. |

The following subsections shortly describes the alternate functions for each port, and relates the overriding signals to the alternate function. Refer to the alternate function description for further details.

Special Function IO Register – SFIOR

| | | | | | | | | | |
|---------------|-----|---|---|---|------|-----|------|--------|-------|
| Bit | 7 | 6 | 5 | 4 | 3 | 2 | 1 | 0 | |
| | TSM | – | – | – | ACME | PUD | PSR0 | PSR321 | SFIOR |
| Read/Write | R/W | R | R | R | R/W | R/W | R/W | R/W | |
| Initial Value | 0 | 0 | 0 | 0 | 0 | 0 | 0 | 0 | |

- **Bit 2 – PUD: Pull-up disable**

When this bit is written to one, the pull-ups in the I/O ports are disabled even if the DDxn and PORTxn Registers are configured to enable the pull-ups ({DDxn, PORTxn} = 0b01). See “[Configuring the Pin](#)” on page 66 for more details about this feature.

Alternate Functions of Port A

The Port A has an alternate function as the address low byte and data lines for the External Memory Interface.

Table 27. Port A Pins Alternate Functions

| Port Pin | Alternate Function |
|----------|--|
| PA7 | AD7 (External memory interface address and data bit 7) |
| PA6 | AD6 (External memory interface address and data bit 6) |
| PA5 | AD5 (External memory interface address and data bit 5) |
| PA4 | AD4 (External memory interface address and data bit 4) |
| PA3 | AD3 (External memory interface address and data bit 3) |
| PA2 | AD2 (External memory interface address and data bit 2) |
| PA1 | AD1 (External memory interface address and data bit 1) |
| PA0 | AD0 (External memory interface address and data bit 0) |

[Table 28](#) and [Table 29](#) relates the alternate functions of Port A to the overriding signals shown in [Figure 33](#) on page 70.

Table 28. Overriding Signals for Alternate Functions in PA7..PA4

| Signal Name | PA7/AD7 | PA6/AD6 | PA5/AD5 | PA4/AD4 |
|-------------|--|--|--|--|
| PUOE | SRE | SRE | SRE | SRE |
| PUOV | $\sim(\overline{WR} ADA^{(1)}) \cdot \overline{PORTA7} \cdot \overline{PUD}$ | $\sim(\overline{WR} ADA) \cdot \overline{PORTA6} \cdot \overline{PUD}$ | $\sim(\overline{WR} ADA) \cdot \overline{PORTA5} \cdot \overline{PUD}$ | $\sim(\overline{WR} ADA) \cdot \overline{PORTA4} \cdot \overline{PUD}$ |
| DDOE | SRE | SRE | SRE | SRE |
| DDOV | $\overline{WR} ADA$ | $\overline{WR} ADA$ | $\overline{WR} ADA$ | $\overline{WR} ADA$ |
| PVOE | SRE | SRE | SRE | SRE |
| PVOV | $A7 \cdot ADA D7 \cdot \overline{OUTPUT} \cdot \overline{WR}$ | $A6 \cdot ADA D6 \cdot \overline{OUTPUT} \cdot \overline{WR}$ | $A5 \cdot ADA D5 \cdot \overline{OUTPUT} \cdot \overline{WR}$ | $A4 \cdot ADA D4 \cdot \overline{OUTPUT} \cdot \overline{WR}$ |
| DIEOE | 0 | 0 | 0 | 0 |
| DIEOV | 0 | 0 | 0 | 0 |
| DI | D7 INPUT | D6 INPUT | D5 INPUT | D4 INPUT |
| AIO | – | – | – | – |

Note: 1. ADA is short for Address Active and represents the time when address is output. See “[External Memory Interface](#)” on page 25 for details.

Table 29. Overriding Signals for Alternate Functions in PA3..PA0

| Signal Name | PA3/AD3 | PA2/AD2 | PA1/AD1 | PA0/AD0 |
|-------------|--|--|--|--|
| PUE | SRE | SRE | SRE | SRE |
| PUEV | $\sim(\overline{WR} ADA) \cdot \overline{PORTA3} \cdot \overline{PUD}$ | $\sim(\overline{WR} ADA) \cdot \overline{PORTA2} \cdot \overline{PUD}$ | $\sim(\overline{WR} ADA) \cdot \overline{PORTA1} \cdot \overline{PUD}$ | $\sim(\overline{WR} ADA) \cdot \overline{PORTA0} \cdot \overline{PUD}$ |
| DDE | SRE | SRE | SRE | SRE |
| DDEV | $\overline{WR} ADA$ | $\overline{WR} ADA$ | $\overline{WR} ADA$ | $\overline{WR} ADA$ |
| PVE | SRE | SRE | SRE | SRE |
| PVEV | $A3 \cdot ADA D3 \text{ OUTPUT} \cdot \overline{WR}$ | $A2 \cdot ADA D2 \text{ OUTPUT} \cdot \overline{WR}$ | $A1 \cdot ADA D1 \text{ OUTPUT} \cdot \overline{WR}$ | $A0 \cdot ADA D0 \text{ OUTPUT} \cdot \overline{WR}$ |
| DIEE | 0 | 0 | 0 | 0 |
| DIEEV | 0 | 0 | 0 | 0 |
| DI | D3 INPUT | D2 INPUT | D1 INPUT | D0 INPUT |
| AIO | – | – | – | – |

Alternate Functions of Port B

The Port B pins with alternate functions are shown in [Table 30](#).

Table 30. Port B Pins Alternate Functions

| Port Pin | Alternate Functions |
|----------|--|
| PB7 | OC2/OC1C ⁽¹⁾ (Output Compare and PWM Output for Timer/Counter2 or Output Compare and PWM Output C for Timer/Counter1) |
| PB6 | OC1B (Output Compare and PWM Output B for Timer/Counter1) |
| PB5 | OC1A (Output Compare and PWM Output A for Timer/Counter1) |
| PB4 | OC0 (Output Compare and PWM Output for Timer/Counter0) |
| PB3 | MISO (SPI Bus Master Input/Slave Output) |
| PB2 | MOSI (SPI Bus Master Output/Slave Input) |
| PB1 | SCK (SPI Bus Serial Clock) |
| PB0 | \overline{SS} (SPI Slave Select input) |

Note: 1. OC1C not applicable in ATmega103 compatibility mode.

The alternate pin configuration is as follows:

- **OC2/OC1C, Bit 7**

OC2, Output Compare Match output: The PB7 pin can serve as an external output for the Timer/Counter2 Output Compare. The pin has to be configured as an output (DDB7 set “one”) to serve this function. The OC2 pin is also the output pin for the PWM mode timer function.

OC1C, Output Compare Match C output: The PB7 pin can serve as an external output for the Timer/Counter1 Output Compare C. The pin has to be configured as an output (DDB7 set (one)) to serve this function. The OC1C pin is also the output pin for the PWM mode timer function.

- **OC1B, Bit 6**

OC1B, Output Compare Match B output: The PB6 pin can serve as an external output for the Timer/Counter1 Output Compare B. The pin has to be configured as an output (DDB6 set (one)) to serve this function. The OC1B pin is also the output pin for the PWM mode timer function.

- **OC1A, Bit 5**

OC1A, Output Compare Match A output: The PB5 pin can serve as an external output for the Timer/Counter1 Output Compare A. The pin has to be configured as an output (DDB5 set (one)) to serve this function. The OC1A pin is also the output pin for the PWM mode timer function.

- **OC0, Bit 4**

OC0, Output Compare Match output: The PB4 pin can serve as an external output for the Timer/Counter0 Output Compare. The pin has to be configured as an output (DDB4 set (one)) to serve this function. The OC0 pin is also the output pin for the PWM mode timer function.

- **MISO – Port B, Bit 3**

MISO: Master Data input, Slave Data output pin for SPI channel. When the SPI is enabled as a master, this pin is configured as an input regardless of the setting of DDB3. When the SPI is enabled as a slave, the data direction of this pin is controlled by DDB3. When the pin is forced to be an input, the pull-up can still be controlled by the PORTB3 bit.

- **MOSI – Port B, Bit 2**

MOSI: SPI Master Data output, Slave Data input for SPI channel. When the SPI is enabled as a slave, this pin is configured as an input regardless of the setting of DDB2. When the SPI is enabled as a master, the data direction of this pin is controlled by DDB2. When the pin is forced to be an input, the pull-up can still be controlled by the PORTB2 bit.

- **SCK – Port B, Bit 1**

SCK: Master Clock output, Slave Clock input pin for SPI channel. When the SPI is enabled as a slave, this pin is configured as an input regardless of the setting of DDB1. When the SPI is enabled as a master, the data direction of this pin is controlled by DDB1. When the pin is forced to be an input, the pull-up can still be controlled by the PORTB1 bit.

- **\overline{SS} – Port B, Bit 0**

\overline{SS} : Slave Port Select input. When the SPI is enabled as a slave, this pin is configured as an input regardless of the setting of DDB0. As a slave, the SPI is activated when this pin is driven low. When the SPI is enabled as a master, the data direction of this pin is controlled by DDB0. When the pin is forced to be an input, the pull-up can still be controlled by the PORTB0 bit.

[Table 31](#) and [Table 32](#) relate the alternate functions of Port B to the overriding signals shown in [Figure 33 on page 70](#). SPI MSTR INPUT and SPI SLAVE OUTPUT constitute the MISO signal, while MOSI is divided into SPI MSTR OUTPUT and SPI SLAVE INPUT.

Table 31. Overriding Signals for Alternate Functions in PB7..PB4

| Signal Name | PB7/OC2/OC1C | PB6/OC1B | PB5/OC1A | PB4/OC0 |
|-------------|--------------------------------|-------------|-------------|------------|
| PUOE | 0 | 0 | 0 | 0 |
| PUOV | 0 | 0 | 0 | 0 |
| DDOE | 0 | 0 | 0 | 0 |
| DDOV | 0 | 0 | 0 | 0 |
| PVOE | OC2/OC1C ENABLE ⁽¹⁾ | OC1B ENABLE | OC1A ENABLE | OC0 ENABLE |
| PVOV | OC2/OC1C ⁽¹⁾ | OC1B | OC1A | OC0B |
| DIEOE | 0 | 0 | 0 | 0 |
| DIEOV | 0 | 0 | 0 | 0 |
| DI | – | – | – | – |
| AIO | – | – | – | – |

Note: 1. See “Output Compare Modulator (OCM1C2)” on page 160 for details. OC1C does not exist in ATmega103 compatibility mode.

Table 32. Overriding Signals for Alternate Functions in PB3..PB0

| Signal Name | PB3/MISO | PB2/MOSI | PB1/SCK | PB0/SS |
|-------------|----------------------------------|----------------------------------|----------------------------------|----------------------------------|
| PUOE | SPE • MSTR | SPE • $\overline{\text{MSTR}}$ | SPE • $\overline{\text{MSTR}}$ | SPE • $\overline{\text{MSTR}}$ |
| PUOV | PORTB3 • $\overline{\text{PUD}}$ | PORTB2 • $\overline{\text{PUD}}$ | PORTB1 • $\overline{\text{PUD}}$ | PORTB0 • $\overline{\text{PUD}}$ |
| DDOE | SPE • MSTR | SPE • $\overline{\text{MSTR}}$ | SPE • $\overline{\text{MSTR}}$ | SPE • $\overline{\text{MSTR}}$ |
| DDOV | 0 | 0 | 0 | 0 |
| PVOE | SPE • $\overline{\text{MSTR}}$ | SPE • MSTR | SPE • MSTR | 0 |
| PVOV | SPI SLAVE OUTPUT | SPI MSTR OUTPUT | SCK OUTPUT | 0 |
| DIEOE | 0 | 0 | 0 | 0 |
| DIEOV | 0 | 0 | 0 | 0 |
| DI | SPI MSTR INPUT | SPI SLAVE INPUT | SCK INPUT | SPI $\overline{\text{SS}}$ |
| AIO | – | – | – | – |

Alternate Functions of Port C

In ATmega103 compatibility mode, Port C is output only. The ATmega128 is by default shipped in compatibility mode. Thus, if the parts are not programmed before they are put on the PCB, PORTC will be output during first power up, and until the ATmega103 compatibility mode is disabled. The Port C has an alternate function as the address high byte for the External Memory Interface.

Table 33. Port C Pins Alternate Functions

| Port Pin | Alternate Function |
|----------|--------------------|
| PC7 | A15 |
| PC6 | A14 |
| PC5 | A13 |
| PC4 | A12 |
| PC3 | A11 |
| PC2 | A10 |
| PC1 | A9 |
| PC0 | A8 |

Table 34 and Table 35 relate the alternate functions of Port C to the overriding signals shown in Figure 33 on page 70.

Table 34. Overriding Signals for Alternate Functions in PC7..PC4

| Signal Name | PC7/A15 | PC6/A14 | PC5/A13 | PC4/A12 |
|-------------|-------------------------------|---------------|---------------|---------------|
| PUOE | SRE • (XMM ⁽¹⁾ <1) | SRE • (XMM<2) | SRE • (XMM<3) | SRE • (XMM<4) |
| PUOV | 0 | 0 | 0 | 0 |
| DDOE | SRE • (XMM<1) | SRE • (XMM<2) | SRE • (XMM<3) | SRE • (XMM<4) |
| DDOV | 1 | 1 | 1 | 1 |
| PVOE | SRE • (XMM<1) | SRE • (XMM<2) | SRE • (XMM<3) | SRE • (XMM<4) |
| PVOV | A15 | A14 | A13 | A12 |
| DIEOE | 0 | 0 | 0 | 0 |
| DIEOV | 0 | 0 | 0 | 0 |
| DI | – | – | – | – |
| AIO | – | – | – | – |

Note: 1. XMM = 0 in ATmega103 compatibility mode.

Table 35. Overriding Signals for Alternate Functions in PC3..PC0⁽¹⁾

| Signal Name | PC3/A11 | PC2/A10 | PC1/A9 | PC0/A8 |
|-------------|---------------|---------------|---------------|---------------|
| PUOE | SRE • (XMM<5) | SRE • (XMM<6) | SRE • (XMM<7) | SRE • (XMM<7) |
| PUOV | 0 | 0 | 0 | 0 |
| DDOE | SRE • (XMM<5) | SRE • (XMM<6) | SRE • (XMM<7) | SRE • (XMM<7) |
| DDOV | 1 | 1 | 1 | 1 |
| PVOE | SRE • (XMM<5) | SRE • (XMM<6) | SRE • (XMM<7) | SRE • (XMM<7) |
| PVOV | A11 | A10 | A9 | A8 |
| DIEOE | 0 | 0 | 0 | 0 |
| DIEOV | 0 | 0 | 0 | 0 |
| DI | – | – | – | – |
| AIO | – | – | – | – |

Note: 1. XMM = 0 in ATmega103 compatibility mode.

Alternate Functions of Port D

The Port D pins with alternate functions are shown in [Table 36](#).

Table 36. Port D Pins Alternate Functions

| Port Pin | Alternate Function |
|----------|--|
| PD7 | T2 (Timer/Counter2 Clock Input) |
| PD6 | T1 (Timer/Counter1 Clock Input) |
| PD5 | XCK1 ⁽¹⁾ (USART1 External Clock Input/Output) |
| PD4 | ICP1 (Timer/Counter1 Input Capture Pin) |
| PD3 | INT3/TXD1 ⁽¹⁾ (External Interrupt3 Input or UART1 Transmit Pin) |
| PD2 | INT2/RXD1 ⁽¹⁾ (External Interrupt2 Input or UART1 Receive Pin) |
| PD1 | INT1/SDA ⁽¹⁾ (External Interrupt1 Input or TWI Serial Data) |
| PD0 | INT0/SCL ⁽¹⁾ (External Interrupt0 Input or TWI Serial Clock) |

Note: 1. XCK1, TXD1, RXD1, SDA, and SCL not applicable in ATmega103 compatibility mode.

The alternate pin configuration is as follows:

- **T2 – Port D, Bit 7**

T2, Timer/Counter2 counter source.

- **T1 – Port D, Bit 6**

T1, Timer/Counter1 counter source.

- **XCK1 – Port D, Bit 5**

XCK1, USART1 External clock. The Data Direction Register (DDD4) controls whether the clock is output (DDD4 set) or input (DDD4 cleared). The XCK1 pin is active only when the USART1 operates in Synchronous mode.

- **ICP1 – Port D, Bit 4**

ICP1 – Input Capture Pin1: The PD4 pin can act as an Input Capture Pin for Timer/Counter1.

- **INT3/TXD1 – Port D, Bit 3**

INT3, External Interrupt source 3: The PD3 pin can serve as an external interrupt source to the MCU.

TXD1, Transmit Data (Data output pin for the USART1). When the USART1 Transmitter is enabled, this pin is configured as an output regardless of the value of DDD3.

- **INT2/RXD1 – Port D, Bit 2**

INT2, External Interrupt source 2. The PD2 pin can serve as an External Interrupt source to the MCU.

RXD1, Receive Data (Data input pin for the USART1). When the USART1 receiver is enabled this pin is configured as an input regardless of the value of DDD2. When the USART forces this pin to be an input, the pull-up can still be controlled by the PORTD2 bit.

- **INT1/SDA – Port D, Bit 1**

INT1, External Interrupt source 1. The PD1 pin can serve as an external interrupt source to the MCU.

SDA, Two-wire Serial Interface Data: When the TWEN bit in TWCR is set (one) to enable the Two-wire Serial Interface, pin PD1 is disconnected from the port and becomes the Serial Data I/O pin for the Two-wire Serial Interface. In this mode, there is a spike filter on the pin to suppress spikes shorter than 50 ns on the input signal, and the pin is driven by an open drain driver with slew-rate limitation.

- **INT0/SCL – Port D, Bit 0**

INT0, External Interrupt source 0. The PD0 pin can serve as an external interrupt source to the MCU.

SCL, Two-wire Serial Interface Clock: When the TWEN bit in TWCR is set (one) to enable the Two-wire Serial Interface, pin PD0 is disconnected from the port and becomes the Serial Clock I/O pin for the Two-wire Serial Interface. In this mode, there is a spike filter on the pin to suppress spikes shorter than 50ns on the input signal, and the pin is driven by an open drain driver with slew-rate limitation.

[Table 37](#) and [Table 38](#) relates the alternate functions of Port D to the overriding signals shown in [Figure 33](#) on page 70.

Table 37. Overriding Signals for Alternate Functions PD7..PD4

| Signal Name | PD7/T2 | PD6/T1 | PD5/XCK1 | PD4/ICP1 |
|-------------|----------|----------|-------------|------------|
| PUE | 0 | 0 | 0 | 0 |
| PUEV | 0 | 0 | 0 | 0 |
| DUE | 0 | 0 | 0 | 0 |
| DUEV | 0 | 0 | 0 | 0 |
| PVE | 0 | 0 | UMSEL1 | 0 |
| PUEV | 0 | 0 | XCK1 OUTPUT | 0 |
| DIE | 0 | 0 | 0 | 0 |
| DIEV | 0 | 0 | 0 | 0 |
| DI | T2 INPUT | T1 INPUT | XCK1 INPUT | ICP1 INPUT |
| AIO | – | – | – | – |

Table 38. Overriding Signals for Alternate Functions in PD3..PD0⁽¹⁾

| Signal Name | PD3/INT3/TXD1 | PD2/INT2/RXD1 | PD1/INT1/SDA | PD0/INT0/SCL |
|-------------|---------------|----------------------------------|----------------------------------|----------------------------------|
| PUE | TXEN1 | RXEN1 | TWEN | TWEN |
| PUEV | 0 | PORTD2 • $\overline{\text{PUD}}$ | PORTD1 • $\overline{\text{PUD}}$ | PORTD0 • $\overline{\text{PUD}}$ |
| DUE | TXEN1 | RXEN1 | TWEN | TWEN |
| DUEV | 1 | 0 | SDA_OUT | SCL_OUT |
| PVE | TXEN1 | 0 | TWEN | TWEN |
| PUEV | TXD1 | 0 | 0 | 0 |
| DIE | INT3 ENABLE | INT2 ENABLE | INT1 ENABLE | INT0 ENABLE |
| DIEV | 1 | 1 | 1 | 1 |
| DI | INT3 INPUT | INT2 INPUT/RXD1 | INT1 INPUT | INT0 INPUT |
| AIO | – | – | SDA INPUT | SCL INPUT |

Note: 1. When enabled, the Two-wire Serial Interface enables Slew-Rate controls on the output pins PD0 and PD1. This is not shown in this table. In addition, spike filters are connected between the AIO outputs shown in the port figure and the digital logic of the TWI module.

Alternate Functions of Port E

The Port E pins with alternate functions are shown in [Table 39](#).

Table 39. Port E Pins Alternate Functions

| Port Pin | Alternate Function |
|----------|---|
| PE7 | INT7/ICP3 ⁽¹⁾ (External Interrupt 7 Input or Timer/Counter3 Input Capture Pin) |
| PE6 | INT6/ T3 ⁽¹⁾ (External Interrupt 6 Input or Timer/Counter3 Clock Input) |
| PE5 | INT5/OC3C ⁽¹⁾ (External Interrupt 5 Input or Output Compare and PWM Output C for Timer/Counter3) |
| PE4 | INT4/OC3B ⁽¹⁾ (External Interrupt4 Input or Output Compare and PWM Output B for Timer/Counter3) |
| PE3 | AIN1/OC3A ⁽¹⁾ (Analog Comparator Negative Input or Output Compare and PWM Output A for Timer/Counter3) |
| PE2 | AIN0/XCK0 ⁽¹⁾ (Analog Comparator Positive Input or USART0 external clock input/output) |
| PE1 | PDO/TXD0 (Programming Data Output or UART0 Transmit Pin) |
| PE0 | PDI/RXD0 (Programming Data Input or UART0 Receive Pin) |

Note: 1. ICP3, T3, OC3C, OC3B, OC3B, OC3A, and XCK0 not applicable in ATmega103 compatibility mode.

- **INT7/ICP3 – Port E, Bit 7**

INT7, External Interrupt source 7: The PE7 pin can serve as an external interrupt source.

ICP3 – Input Capture Pin3: The PE7 pin can act as an Input Capture Pin for Timer/Counter3.

- **INT6/T3 – Port E, Bit 6**

INT6, External Interrupt source 6: The PE6 pin can serve as an external interrupt source.

T3, Timer/Counter3 counter source.

- **INT5/OC3C – Port E, Bit 5**

INT5, External Interrupt source 5: The PE5 pin can serve as an External Interrupt source.

OC3C, Output Compare Match C output: The PE5 pin can serve as an External output for the Timer/Counter3 Output Compare C. The pin has to be configured as an output (DDE5 set “one”) to serve this function. The OC3C pin is also the output pin for the PWM mode timer function.

- **INT4/OC3B – Port E, Bit 4**

INT4, External Interrupt source 4: The PE4 pin can serve as an External Interrupt source.

OC3B, Output Compare Match B output: The PE4 pin can serve as an External output for the Timer/Counter3 Output Compare B. The pin has to be configured as an output (DDE4 set (one)) to serve this function. The OC3B pin is also the output pin for the PWM mode timer function.

- **AIN1/OC3A – Port E, Bit 3**

AIN1 – Analog Comparator Negative input. This pin is directly connected to the negative input of the Analog Comparator.

OC3A, Output Compare Match A output: The PE3 pin can serve as an External output for the Timer/Counter3 Output Compare A. The pin has to be configured as an output (DDE3 set “one”) to serve this function. The OC3A pin is also the output pin for the PWM mode timer function.

- **AIN0/XCK0 – Port E, Bit 2**

AIN0 – Analog Comparator Positive input. This pin is directly connected to the positive input of the Analog Comparator.

XCK0, USART0 External clock. The Data Direction Register (DDE2) controls whether the clock is output (DDE2 set) or input (DDE2 cleared). The XCK0 pin is active only when the USART0 operates in Synchronous mode.

- **PDO/TXD0 – Port E, Bit 1**

PDO, SPI Serial Programming Data Output. During Serial Program Downloading, this pin is used as data output line for the ATmega128.

TXD0, UART0 Transmit pin.

- **PDI/RXD0 – Port E, Bit 0**

PDI, SPI Serial Programming Data Input. During Serial Program Downloading, this pin is used as data input line for the ATmega128.

RXD0, USART0 Receive Pin. Receive Data (Data input pin for the USART0). When the USART0 receiver is enabled this pin is configured as an input regardless of the value of DDRE0. When the USART0 forces this pin to be an input, a logical one in PORTE0 will turn on the internal pull-up.

[Table 40](#) and [Table 41](#) relates the alternate functions of Port E to the overriding signals shown in [Figure 33](#) on page 70.

Table 40. Overriding Signals for Alternate Functions PE7..PE4

| Signal Name | PE7/INT7/ICP3 | PE6/INT6/T3 | PE5/INT5/OC3C | PE4/INT4/OC3B |
|-------------|-----------------------|---------------------|---------------|---------------|
| PUOE | 0 | 0 | 0 | 0 |
| PUOV | 0 | 0 | 0 | 0 |
| DDOE | 0 | 0 | 0 | 0 |
| DDOV | 0 | 0 | 0 | 0 |
| PVOE | 0 | 0 | OC3C ENABLE | OC3B ENABLE |
| PVOV | 0 | 0 | OC3C | OC3B |
| DIEOE | INT7 ENABLE | INT6 ENABLE | INT5 ENABLE | INT4 ENABLE |
| DIEOV | 1 | 1 | 1 | 1 |
| DI | INT7 INPUT/ICP3 INPUT | INT7 INPUT/T3 INPUT | INT5 INPUT | INT4 INPUT |
| AIO | – | – | – | – |

Table 41. Overriding Signals for Alternate Functions in PE3..PE0

| Signal Name | PE3/AIN1/OC3A | PE2/AIN0/XCK0 | PE1/PDO/TXD0 | PE0/PDI/RXD0 |
|-------------|---------------|---------------|--------------|---------------------------|
| PUOE | 0 | 0 | TXEN0 | RXEN0 |
| PUOV | 0 | 0 | 0 | PORTE0 • \overline{PUD} |
| DDOE | 0 | 0 | TXEN0 | RXEN0 |
| DDOV | 0 | 0 | 1 | 0 |
| PVOE | OC3B ENABLE | UMSEL0 | TXEN0 | 0 |
| PVOV | OC3B | XCK0 OUTPUT | TXD0 | 0 |
| DIEOE | 0 | 0 | 0 | 0 |
| DIEOV | 0 | 0 | 0 | 0 |
| DI | 0 | XCK0 INPUT | – | RXD0 |
| AIO | AIN1 INPUT | AIN0 INPUT | – | – |

Alternate Functions of Port F

The Port F has an alternate function as analog input for the ADC as shown in Table 42. If some Port F pins are configured as outputs, it is essential that these do not switch when a conversion is in progress. This might corrupt the result of the conversion. In ATmega103 compatibility mode Port F is input only. If the JTAG interface is enabled, the pull-up resistors on pins PF7(TDI), PF5(TMS), and PF4(TCK) will be activated even if a Reset occurs.

Table 42. Port F Pins Alternate Functions

| Port Pin | Alternate Function |
|----------|---|
| PF7 | ADC7/TDI (ADC input channel 7 or JTAG Test Data Input) |
| PF6 | ADC6/TDO (ADC input channel 6 or JTAG Test Data Output) |
| PF5 | ADC5/TMS (ADC input channel 5 or JTAG Test Mode Select) |
| PF4 | ADC4/TCK (ADC input channel 4 or JTAG Test Clock) |
| PF3 | ADC3 (ADC input channel 3) |
| PF2 | ADC2 (ADC input channel 2) |
| PF1 | ADC1 (ADC input channel 1) |
| PF0 | ADC0 (ADC input channel 0) |

- **TDI, ADC7 – Port F, Bit 7**

ADC7, Analog to Digital Converter, Channel 7.

TDI, JTAG Test Data In: Serial input data to be shifted in to the Instruction Register or Data Register (scan chains). When the JTAG interface is enabled, this pin can not be used as an I/O pin.

- **TDO, ADC6 – Port F, Bit 6**

ADC6, Analog to Digital Converter, Channel 6.

TDO, JTAG Test Data Out: Serial output data from Instruction Register or Data Register. When the JTAG interface is enabled, this pin can not be used as an I/O pin.

The TDO pin is tri-stated unless TAP states that shift out data are entered.

- **TMS, ADC5 – Port F, Bit 5**

ADC5, Analog to Digital Converter, Channel 5.

TMS, JTAG Test Mode Select: This pin is used for navigating through the TAP-controller state machine. When the JTAG interface is enabled, this pin can not be used as an I/O pin.

- **TCK, ADC4 – Port F, Bit 4**

ADC4, Analog to Digital Converter, Channel 4.

TCK, JTAG Test Clock: JTAG operation is synchronous to TCK. When the JTAG interface is enabled, this pin can not be used as an I/O pin.

- **ADC3 – ADC0 – Port F, Bit 3..0**

Analog to Digital Converter, Channel 3..0.

Table 43. Overriding Signals for Alternate Functions in PF7..PF4

| Signal Name | PF7/ADC7/TDI | PF6/ADC6/TDO | PF5/ADC5/TMS | PF4/ADC4/TCK |
|-------------|----------------|------------------------|----------------|----------------|
| PUOE | JTAGEN | JTAGEN | JTAGEN | JTAGEN |
| PUOV | 1 | 0 | 1 | 1 |
| DDOE | JTAGEN | JTAGEN | JTAGEN | JTAGEN |
| DDOV | 0 | SHIFT_IR + SHIFT_DR | 0 | 0 |
| PVOE | 0 | JTAGEN | 0 | 0 |
| PVOV | 0 | TDO | 0 | 0 |
| DIEOE | JTAGEN | JTAGEN | JTAGEN | JTAGEN |
| DIEOV | 0 | 0 | 0 | 0 |
| DI | – | – | – | – |
| AIO | TDI/ADC7 INPUT | ADC6 INPUT | TMS/ADC5 INPUT | TCK/ADC4 INPUT |

Table 44. Overriding Signals for Alternate Functions in PF3..PF0

| Signal Name | PF3/ADC3 | PF2/ADC2 | PF1/ADC1 | PF0/ADC0 |
|-------------|------------|------------|------------|------------|
| PUOE | 0 | 0 | 0 | 0 |
| PUOV | 0 | 0 | 0 | 0 |
| DDOE | 0 | 0 | 0 | 0 |
| DDOV | 0 | 0 | 0 | 0 |
| PVOE | 0 | 0 | 0 | 0 |
| PVOV | 0 | 0 | 0 | 0 |
| DIEOE | 0 | 0 | 0 | 0 |
| DIEOV | 0 | 0 | 0 | 0 |
| DI | – | – | – | – |
| AIO | ADC3 INPUT | ADC2 INPUT | ADC1 INPUT | ADC0 INPUT |

Alternate Functions of Port G

In Atmel® AVR® ATmega103 compatibility mode, only the alternate functions are the defaults for Port G, and Port G cannot be used as General Digital Port Pins. The alternate pin configuration is as follows:

Table 45. Port G Pins Alternate Functions

| Port Pin | Alternate Function |
|----------|---|
| PG4 | TOSC1 (RTC Oscillator Timer/Counter0) |
| PG3 | TOSC2 (RTC Oscillator Timer/Counter0) |
| PG2 | ALE (Address Latch Enable to external memory) |
| PG1 | \overline{RD} (Read strobe to external memory) |
| PG0 | \overline{WR} (Write strobe to external memory) |

- **TOSC1 – Port G, Bit 4**

TOSC1, Timer Oscillator pin 1: When the AS0 bit in ASSR is set (one) to enable asynchronous clocking of Timer/Counter0, pin PG4 is disconnected from the port, and becomes the input of the inverting Oscillator amplifier. In this mode, a Crystal Oscillator is connected to this pin, and the pin can not be used as an I/O pin.

- **TOSC2 – Port G, Bit 3**

TOSC2, Timer Oscillator pin 2: When the AS0 bit in ASSR is set (one) to enable asynchronous clocking of Timer/Counter0, pin PG3 is disconnected from the port, and becomes the inverting output of the Oscillator amplifier. In this mode, a Crystal Oscillator is connected to this pin, and the pin can not be used as an I/O pin.

- **ALE – Port G, Bit 2**

ALE is the external data memory Address Latch Enable signal.

- **\overline{RD} – Port G, Bit 1**

\overline{RD} is the external data memory read control strobe.

- **\overline{WR} – Port G, Bit 0**

\overline{WR} is the external data memory write control strobe.

[Table 46](#) and [Table 47](#) relates the alternate functions of Port G to the overriding signals shown in [Figure 33](#) on page 70.

Table 46. Overriding Signals for Alternate Functions in PG4..PG1

| Signal Name | PG4/TOSC1 | PG3/TOSC2 | PG2/ALE | PG1/ \overline{RD} |
|-------------|----------------|-----------------|---------|----------------------|
| PUOE | AS0 | AS0 | SRE | SRE |
| PUOV | 0 | 0 | 0 | 0 |
| DDOE | AS0 | AS0 | SRE | SRE |
| DDOV | 0 | 0 | 1 | 1 |
| PVOE | 0 | 0 | SRE | SRE |
| PVOV | 0 | 0 | ALE | RD |
| DIEOE | AS0 | AS0 | 0 | 0 |
| DIEOV | 0 | 0 | 0 | 0 |
| DI | – | – | – | – |
| AIO | T/C0 OSC INPUT | T/C0 OSC OUTPUT | – | – |

Table 47. Overriding Signals for Alternate Functions in PG0

| Signal Name | PG0/WR |
|-------------|--------|
| PUOE | SRE |
| PUOV | 0 |
| DDOE | SRE |
| DDOV | 1 |
| PVOE | SRE |
| PVOV | WR |
| DIEOE | 0 |
| DIEOV | 0 |
| DI | – |
| AIO | – |

Register Description for I/O Ports

Port A Data Register – PORTA

| | | | | | | | | | |
|---------------|---------------|---------------|---------------|---------------|---------------|---------------|---------------|---------------|-------|
| Bit | 7 | 6 | 5 | 4 | 3 | 2 | 1 | 0 | |
| | PORTA7 | PORTA6 | PORTA5 | PORTA4 | PORTA3 | PORTA2 | PORTA1 | PORTA0 | PORTA |
| Read/Write | R/W | R/W | R/W | R/W | R/W | R/W | R/W | R/W | |
| Initial Value | 0 | 0 | 0 | 0 | 0 | 0 | 0 | 0 | |

Port A Data Direction Register – DDRA

| | | | | | | | | | |
|---------------|-------------|-------------|-------------|-------------|-------------|-------------|-------------|-------------|------|
| Bit | 7 | 6 | 5 | 4 | 3 | 2 | 1 | 0 | |
| | DDA7 | DDA6 | DDA5 | DDA4 | DDA3 | DDA2 | DDA1 | DDA0 | DDRA |
| Read/Write | R/W | R/W | R/W | R/W | R/W | R/W | R/W | R/W | |
| Initial Value | 0 | 0 | 0 | 0 | 0 | 0 | 0 | 0 | |

Port A Input Pins Address – PINA

| | | | | | | | | | |
|---------------|--------------|--------------|--------------|--------------|--------------|--------------|--------------|--------------|------|
| Bit | 7 | 6 | 5 | 4 | 3 | 2 | 1 | 0 | |
| | PINA7 | PINA6 | PINA5 | PINA4 | PINA3 | PINA2 | PINA1 | PINA0 | PINA |
| Read/Write | R | R | R | R | R | R | R | R | |
| Initial Value | N/A | N/A | N/A | N/A | N/A | N/A | N/A | N/A | |

Port B Data Register – PORTB

| | | | | | | | | | |
|---------------|---------------|---------------|---------------|---------------|---------------|---------------|---------------|---------------|-------|
| Bit | 7 | 6 | 5 | 4 | 3 | 2 | 1 | 0 | |
| | PORTB7 | PORTB6 | PORTB5 | PORTB4 | PORTB3 | PORTB2 | PORTB1 | PORTB0 | PORTB |
| Read/Write | R/W | R/W | R/W | R/W | R/W | R/W | R/W | R/W | |
| Initial Value | 0 | 0 | 0 | 0 | 0 | 0 | 0 | 0 | |

Port B Data Direction Register – DDRB

| | | | | | | | | | |
|---------------|-------------|-------------|-------------|-------------|-------------|-------------|-------------|-------------|------|
| Bit | 7 | 6 | 5 | 4 | 3 | 2 | 1 | 0 | |
| | DDB7 | DDB6 | DDB5 | DDB4 | DDB3 | DDB2 | DDB1 | DDB0 | DDRB |
| Read/Write | R/W | R/W | R/W | R/W | R/W | R/W | R/W | R/W | |
| Initial Value | 0 | 0 | 0 | 0 | 0 | 0 | 0 | 0 | |

Port B Input Pins Address – PINB

| | | | | | | | | | |
|---------------|--------------|--------------|--------------|--------------|--------------|--------------|--------------|--------------|------|
| Bit | 7 | 6 | 5 | 4 | 3 | 2 | 1 | 0 | |
| | PINB7 | PINB6 | PINB5 | PINB4 | PINB3 | PINB2 | PINB1 | PINB0 | PINB |
| Read/Write | R | R | R | R | R | R | R | R | |
| Initial Value | N/A | N/A | N/A | N/A | N/A | N/A | N/A | N/A | |

Port C Data Register – PORTC

| | | | | | | | | | |
|---------------|---------------|---------------|---------------|---------------|---------------|---------------|---------------|---------------|-------|
| Bit | 7 | 6 | 5 | 4 | 3 | 2 | 1 | 0 | |
| | PORTC7 | PORTC6 | PORTC5 | PORTC4 | PORTC3 | PORTC2 | PORTC1 | PORTC0 | PORTC |
| Read/Write | R/W | R/W | R/W | R/W | R/W | R/W | R/W | R/W | |
| Initial Value | 0 | 0 | 0 | 0 | 0 | 0 | 0 | 0 | |

Port C Data Direction Register – DDRC

| | | | | | | | | | |
|---------------|-------------|-------------|-------------|-------------|-------------|-------------|-------------|-------------|------|
| Bit | 7 | 6 | 5 | 4 | 3 | 2 | 1 | 0 | |
| | DDC7 | DDC6 | DDC5 | DDC4 | DDC3 | DDC2 | DDC1 | DDC0 | DDRC |
| Read/Write | R/W | R/W | R/W | R/W | R/W | R/W | R/W | R/W | |
| Initial Value | 0 | 0 | 0 | 0 | 0 | 0 | 0 | 0 | |

Port C Input Pins Address – PINC

| Bit | 7 | 6 | 5 | 4 | 3 | 2 | 1 | 0 | |
|---------------|--------------|--------------|--------------|--------------|--------------|--------------|--------------|--------------|------|
| | PINC7 | PINC6 | PINC5 | PINC4 | PINC3 | PINC2 | PINC1 | PINC0 | PINC |
| Read/Write | R | R | R | R | R | R | R | R | |
| Initial Value | N/A | N/A | N/A | N/A | N/A | N/A | N/A | N/A | |

In Atmel® AVR®ATmega103 compatibility mode, DDRC and PINC Registers are initialized to being Push-Pull Zero Output. The port pins assumes their initial value, even if the clock is not running. Note that the DDRC and PINC Registers are available in ATmega103 compatibility mode, and should not be used for 100% back-ward compatibility.

Port D Data Register – PORTD

| Bit | 7 | 6 | 5 | 4 | 3 | 2 | 1 | 0 | |
|---------------|---------------|---------------|---------------|---------------|---------------|---------------|---------------|---------------|-------|
| | PORTD7 | PORTD6 | PORTD5 | PORTD4 | PORTD3 | PORTD2 | PORTD1 | PORTD0 | PORTD |
| Read/Write | R/W | R/W | R/W | R/W | R/W | R/W | R/W | R/W | |
| Initial Value | 0 | 0 | 0 | 0 | 0 | 0 | 0 | 0 | |

Port D Data Direction Register – DDRD

| Bit | 7 | 6 | 5 | 4 | 3 | 2 | 1 | 0 | |
|---------------|-------------|-------------|-------------|-------------|-------------|-------------|-------------|-------------|------|
| | DDD7 | DDD6 | DDD5 | DDD4 | DDD3 | DDD2 | DDD1 | DDD0 | DDRD |
| Read/Write | R/W | R/W | R/W | R/W | R/W | R/W | R/W | R/W | |
| Initial Value | 0 | 0 | 0 | 0 | 0 | 0 | 0 | 0 | |

Port D Input Pins Address – PIND

| Bit | 7 | 6 | 5 | 4 | 3 | 2 | 1 | 0 | |
|---------------|--------------|--------------|--------------|--------------|--------------|--------------|--------------|--------------|------|
| | PIND7 | PIND6 | PIND5 | PIND4 | PIND3 | PIND2 | PIND1 | PIND0 | PIND |
| Read/Write | R | R | R | R | R | R | R | R | |
| Initial Value | N/A | N/A | N/A | N/A | N/A | N/A | N/A | N/A | |

Port E Data Register – PORTE

| Bit | 7 | 6 | 5 | 4 | 3 | 2 | 1 | 0 | |
|---------------|---------------|---------------|---------------|---------------|---------------|---------------|---------------|---------------|-------|
| | PORTE7 | PORTE6 | PORTE5 | PORTE4 | PORTE3 | PORTE2 | PORTE1 | PORTE0 | PORTE |
| Read/Write | R/W | R/W | R/W | R/W | R/W | R/W | R/W | R/W | |
| Initial Value | 0 | 0 | 0 | 0 | 0 | 0 | 0 | 0 | |

Port E Data Direction Register – DDRE

| Bit | 7 | 6 | 5 | 4 | 3 | 2 | 1 | 0 | |
|---------------|-------------|-------------|-------------|-------------|-------------|-------------|-------------|-------------|------|
| | DDE7 | DDE6 | DDE5 | DDE4 | DDE3 | DDE2 | DDE1 | DDE0 | DDRE |
| Read/Write | R/W | R/W | R/W | R/W | R/W | R/W | R/W | R/W | |
| Initial Value | 0 | 0 | 0 | 0 | 0 | 0 | 0 | 0 | |

Port E Input Pins Address – PINE

| Bit | 7 | 6 | 5 | 4 | 3 | 2 | 1 | 0 | |
|---------------|--------------|--------------|--------------|--------------|--------------|--------------|--------------|--------------|------|
| | PINE7 | PINE6 | PINE5 | PINE4 | PINE3 | PINE2 | PINE1 | PINE0 | PINF |
| Read/Write | R | R | R | R | R | R | R | R | |
| Initial Value | N/A | N/A | N/A | N/A | N/A | N/A | N/A | N/A | |

Port F Data Register – PORTF

| Bit | 7 | 6 | 5 | 4 | 3 | 2 | 1 | 0 | |
|---------------|---------------|---------------|---------------|---------------|---------------|---------------|---------------|---------------|-------|
| | PORTF7 | PORTF6 | PORTF5 | PORTF4 | PORTF3 | PORTF2 | PORTF1 | PORTF0 | PORTF |
| Read/Write | R/W | R/W | R/W | R/W | R/W | R/W | R/W | R/W | |
| Initial Value | 0 | 0 | 0 | 0 | 0 | 0 | 0 | 0 | |

Port F Data Direction Register – DDRF

| | | | | | | | | | |
|---------------|-------------|-------------|-------------|-------------|-------------|-------------|-------------|-------------|-------------|
| Bit | 7 | 6 | 5 | 4 | 3 | 2 | 1 | 0 | |
| | DDF7 | DDF6 | DDF5 | DDF4 | DDF3 | DDF2 | DDF1 | DDF0 | DDRF |
| Read/Write | R/W | R/W | R/W | R/W | R/W | R/W | R/W | R/W | |
| Initial Value | 0 | 0 | 0 | 0 | 0 | 0 | 0 | 0 | |

Port F Input Pins Address – PINF

| | | | | | | | | | |
|---------------|--------------|--------------|--------------|--------------|--------------|--------------|--------------|--------------|-------------|
| Bit | 7 | 6 | 5 | 4 | 3 | 2 | 1 | 0 | |
| | PINF7 | PINF6 | PINF5 | PINF4 | PINF3 | PINF2 | PINF1 | PINF0 | PINF |
| Read/Write | R | R | R | R | R | R | R | R | |
| Initial Value | N/A | N/A | N/A | N/A | N/A | N/A | N/A | N/A | |

Note that PORTF and DDRF Registers are not available in Atmel® AVR® ATmega103 compatibility mode where Port F serves as digital input only.

Port G Data Register – PORTG

| | | | | | | | | | |
|---------------|---|---|---|---------------|---------------|---------------|---------------|---------------|--------------|
| Bit | 7 | 6 | 5 | 4 | 3 | 2 | 1 | 0 | |
| | – | – | – | PORTG4 | PORTG3 | PORTG2 | PORTG1 | PORTG0 | PORTG |
| Read/Write | R | R | R | R/W | R/W | R/W | R/W | R/W | |
| Initial Value | 0 | 0 | 0 | 0 | 0 | 0 | 0 | 0 | |

Port G Data Direction Register – DDRG

| | | | | | | | | | |
|---------------|---|---|---|-------------|-------------|-------------|-------------|-------------|-------------|
| Bit | 7 | 6 | 5 | 4 | 3 | 2 | 1 | 0 | |
| | – | – | – | DDG4 | DDG3 | DDG2 | DDG1 | DDG0 | DDRG |
| Read/Write | R | R | R | R/W | R/W | R/W | R/W | R/W | |
| Initial Value | 0 | 0 | 0 | 0 | 0 | 0 | 0 | 0 | |

Port G Input Pins Address – PING

| | | | | | | | | | |
|---------------|---|---|---|--------------|--------------|--------------|--------------|--------------|-------------|
| Bit | 7 | 6 | 5 | 4 | 3 | 2 | 1 | 0 | |
| | – | – | – | PING4 | PING3 | PING2 | PING1 | PING0 | PING |
| Read/Write | R | R | R | R | R | R | R | R | |
| Initial Value | 0 | 0 | 0 | N/A | N/A | N/A | N/A | N/A | |

Note that PORTG, DDRG, and PING are not available in ATmega103 compatibility mode. In the ATmega103 compatibility mode Port G serves its alternate functions only (TOSC1, TOSC2, \overline{WR} , \overline{RD} and ALE).

External Interrupts

The External Interrupts are triggered by the INT7:0 pins. Observe that, if enabled, the interrupts will trigger even if the INT7:0 pins are configured as outputs. This feature provides a way of generating a software interrupt. The External Interrupts can be triggered by a falling or rising edge or a low level. This is set up as indicated in the specification for the External Interrupt Control Registers – EICRA (INT3:0) and EICRB (INT7:4). When the external interrupt is enabled and is configured as level triggered, the interrupt will trigger as long as the pin is held low. Note that recognition of falling or rising edge interrupts on INT7:4 requires the presence of an I/O clock, described in “[Clock Systems and their Distribution](#)” on page 35. Low level interrupts and the edge interrupt on INT3:0 are detected asynchronously. This implies that these interrupts can be used for waking the part also from sleep modes other than Idle mode. The I/O clock is halted in all sleep modes except Idle mode.

Note that if a level triggered interrupt is used for wake-up from Power-down mode, the changed level must be held for some time to wake up the MCU. This makes the MCU less sensitive to noise. The changed level is sampled twice by the Watchdog Oscillator clock. The period of the Watchdog Oscillator is 1µs (nominal) at 5.0V and 25°C. The frequency of the Watchdog Oscillator is voltage dependent as shown in the “[Electrical Characteristics](#)” on page 318. The MCU will wake up if the input has the required level during this sampling or if it is held until the end of the start-up time. The start-up time is defined by the SUT fuses as described in “[Clock Systems and their Distribution](#)” on page 35. If the level is sampled twice by the Watchdog Oscillator clock but disappears before the end of the start-up time, the MCU will still wake up, but no interrupt will be generated. The required level must be held long enough for the MCU to complete the wake up to trigger the level interrupt.

External Interrupt Control Register A – EICRA

| | | | | | | | | | |
|---------------|--|-----|-----|-----|-----|-----|-----|-----|-------|
| Bit | 7 | 6 | 5 | 4 | 3 | 2 | 1 | 0 | |
| | ISC31 ISC30 ISC21 ISC20 ISC11 ISC10 ISC01 ISC00 | | | | | | | | EICRA |
| Read/Write | R/W | R/W | R/W | R/W | R/W | R/W | R/W | R/W | R/W |
| Initial Value | 0 | 0 | 0 | 0 | 0 | 0 | 0 | 0 | |

This Register can not be reached in Atmel® AVR®ATmega103 compatibility mode, but the initial value defines INT3:0 as low level interrupts, as in ATmega103.

- **Bits 7..0 – ISC31, ISC30 – ISC00, ISC00: External Interrupt 3 - 0 Sense Control Bits**

The External Interrupts 3 - 0 are activated by the external pins INT3:0 if the SREG I-flag and the corresponding interrupt mask in the EIMSK is set. The level and edges on the external pins that activate the interrupts are defined in [Table 48](#). Edges on INT3..INT0 are registered asynchronously. Pulses on INT3:0 pins wider than the minimum pulse width given in [Table 49](#) will generate an interrupt. Shorter pulses are not guaranteed to generate an interrupt. If low level interrupt is selected, the low level must be held until the completion of the currently executing instruction to generate an interrupt. If enabled, a level triggered interrupt will generate an interrupt request as long as the pin is held low. When changing the ISCn bit, an interrupt can occur. Therefore, it is recommended to first disable INTn by clearing its Interrupt Enable bit in the EIMSK Register. Then, the ISCn bit can be changed. Finally, the INTn interrupt flag should be cleared by writing a logical one to its Interrupt Flag bit (INTFn) in the EIFR Register before the interrupt is re-enabled.

Table 48. Interrupt Sense Control⁽¹⁾

| ISCn1 | ISCn0 | Description |
|-------|-------|---|
| 0 | 0 | The low level of INTn generates an interrupt request. |
| 0 | 1 | Reserved |
| 1 | 0 | The falling edge of INTn generates asynchronously an interrupt request. |
| 1 | 1 | The rising edge of INTn generates asynchronously an interrupt request. |

Note: 1. n = 3, 2, 1 or 0.

When changing the ISCn1/ISCn0 bits, the interrupt must be disabled by clearing its Interrupt Enable bit in the EIMSK Register. Otherwise an interrupt can occur when the bits are changed.

Table 49. Asynchronous External Interrupt Characteristics

| Symbol | Parameter | Condition | Min | Typ | Max | Units |
|-----------|---|-----------|-----|-----|-----|-------|
| t_{INT} | Minimum pulse width for asynchronous external interrupt | | | 50 | | ns |

External Interrupt Control Register B – EICRB

| Bit | 7 | 6 | 5 | 4 | 3 | 2 | 1 | 0 | |
|---------------|-------|-------|-------|-------|-------|-------|-------|-------|-------|
| | ISC71 | ISC70 | ISC61 | ISC60 | ISC51 | ISC50 | ISC41 | ISC40 | EICRB |
| Read/Write | R/W | R/W | R/W | R/W | R/W | R/W | R/W | R/W | |
| Initial Value | 0 | 0 | 0 | 0 | 0 | 0 | 0 | 0 | |

• Bits 7..0 – ISC71, ISC70 - ISC41, ISC40: External Interrupt 7 - 4 Sense Control Bits

The External Interrupts 7 - 4 are activated by the external pins INT7:4 if the SREG I-flag and the corresponding interrupt mask in the EIMSK is set. The level and edges on the external pins that activate the interrupts are defined in Table 50. The value on the INT7:4 pins are sampled before detecting edges. If edge or toggle interrupt is selected, pulses that last longer than one clock period will generate an interrupt. Shorter pulses are not guaranteed to generate an interrupt. Observe that CPU clock frequency can be lower than the XTAL frequency if the XTAL divider is enabled. If low level interrupt is selected, the low level must be held until the completion of the currently executing instruction to generate an interrupt. If enabled, a level triggered interrupt will generate an interrupt request as long as the pin is held low.

Table 50. Interrupt Sense Control⁽¹⁾

| ISCn1 | ISCn0 | Description |
|-------|-------|--|
| 0 | 0 | The low level of INTn generates an interrupt request. |
| 0 | 1 | Any logical change on INTn generates an interrupt request |
| 1 | 0 | The falling edge between two samples of INTn generates an interrupt request. |
| 1 | 1 | The rising edge between two samples of INTn generates an interrupt request. |

Note: 1. n = 7, 6, 5 or 4.

When changing the ISCn1/ISCn0 bits, the interrupt must be disabled by clearing its Interrupt Enable bit in the EIMSK Register. Otherwise an interrupt can occur when the bits are changed.

External Interrupt Mask Register – EIMSK

| | | | | | | | | | |
|---------------|------|------|------|------|------|------|------|------|-------|
| Bit | 7 | 6 | 5 | 4 | 3 | 2 | 1 | 0 | |
| | INT7 | INT6 | INT5 | INT4 | INT3 | INT2 | INT1 | INT0 | EIMSK |
| Read/Write | R/W | R/W | R/W | R/W | R/W | R/W | R/W | R/W | |
| Initial Value | 0 | 0 | 0 | 0 | 0 | 0 | 0 | 0 | |

- **Bits 7..0 – INT7 – INT0: External Interrupt Request 7 - 0 Enable**

When an INT7 – INT0 bit is written to one and the I-bit in the Status Register (SREG) is set (one), the corresponding external pin interrupt is enabled. The Interrupt Sense Control bits in the External Interrupt Control Registers – EICRA and EICRB – defines whether the external interrupt is activated on rising or falling edge or level sensed. Activity on any of these pins will trigger an interrupt request even if the pin is enabled as an output. This provides a way of generating a software interrupt.

External Interrupt Flag Register – EIFR

| | | | | | | | | | |
|---------------|-------|-------|-------|-------|-------|-------|-------|-------|------|
| Bit | 7 | 6 | 5 | 4 | 3 | 2 | 1 | 0 | |
| | INTF7 | INTF6 | INTF5 | INTF4 | INTF3 | INTF2 | INTF1 | INTF0 | EIFR |
| Read/Write | R/W | R/W | R/W | R/W | R/W | R/W | R/W | R/W | |
| Initial Value | 0 | 0 | 0 | 0 | 0 | 0 | 0 | 0 | |

- **Bits 7..0 – INTF7 - INTF0: External Interrupt Flags 7 - 0**

When an edge or logic change on the INT7:0 pin triggers an interrupt request, INTF7:0 becomes set (one). If the I-bit in SREG and the corresponding interrupt enable bit, INT7:0 in EIMSK, are set (one), the MCU will jump to the interrupt vector. The flag is cleared when the interrupt routine is executed. Alternatively, the flag can be cleared by writing a logical one to it. These flags are always cleared when INT7:0 are configured as level interrupt. Note that when entering sleep mode with the INT3:0 interrupts disabled, the input buffers on these pins will be disabled. This may cause a logic change in internal signals which will set the INTF3:0 flags. See [“Digital Input Enable and Sleep Modes” on page 69](#) for more information.

8-bit Timer/Counter0 with PWM and Asynchronous Operation

Timer/Counter0 is a general purpose, single channel, 8-bit Timer/Counter module. The main features are:

- Single Channel Counter
- Clear Timer on Compare Match (Auto Reload)
- Glitch-free, Phase Correct Pulse Width Modulator (PWM)
- Frequency Generator
- 10-bit Clock Prescaler
- Overflow and Compare Match Interrupt Sources (TOV0 and OCF0)
- Allows Clocking from External 32kHz Watch Crystal Independent of the I/O Clock

Overview

A simplified block diagram of the 8-bit Timer/Counter is shown in Figure 34. For the actual placement of I/O pins, refer to “Pin Configurations” on page 2. CPU accessible I/O registers, including I/O bits and I/O pins, are shown in bold. The device-specific I/O register and bit locations are listed in the “8-bit Timer/Counter Register Description” on page 103.

Figure 34. 8-bit Timer/Counter Block Diagram



Registers

The Timer/Counter (TCNT0) and Output Compare Register (OCR0) are 8-bit registers. Interrupt request (shortened as Int.Req.) signals are all visible in the Timer Interrupt Flag Register (TIFR). All interrupts are individually masked with the Timer Interrupt Mask Register (TIMSK). TIFR and TIMSK are not shown in the figure since these registers are shared by other timer units.

The Timer/Counter can be clocked internally, via the prescaler, or asynchronously clocked from the TOSC1/2 pins, as detailed later in this section. The asynchronous operation is controlled by the Asynchronous Status Register (ASSR). The Clock Select logic block controls which clock source the Timer/Counter uses to increment (or decrement) its value. The Timer/Counter is inac-

tive when no clock source is selected. The output from the clock select logic is referred to as the timer clock (clk_{T0}).

The double buffered Output Compare Register (OCR0) is compared with the Timer/Counter value at all times. The result of the compare can be used by the waveform generator to generate a PWM or variable frequency output on the Output Compare Pin (OC0). See “Output Compare Unit” on page 94. for details. The compare match event will also set the compare flag (OCF0) which can be used to generate an output compare interrupt request.

Definitions

Many register and bit references in this document are written in general form. A lower case “n” replaces the Timer/Counter number, in this case 0. However, when using the register or bit defines in a program, the precise form must be used (i.e., TCNT0 for accessing Timer/Counter0 counter value and so on).

The definitions in Table 51 are also used extensively throughout the document.

Table 51. Definitions

| | |
|--------|--|
| BOTTOM | The counter reaches the BOTTOM when it becomes zero (0x00). |
| MAX | The counter reaches its MAXimum when it becomes 0xFF (decimal 255). |
| TOP | The counter reaches the TOP when it becomes equal to the highest value in the count sequence. The TOP value can be assigned to be the fixed value 0xFF (MAX) or the value stored in the OCR0 Register. The assignment is dependent on the mode of operation. |

Timer/Counter Clock Sources

The Timer/Counter can be clocked by an internal synchronous or an external asynchronous clock source. The clock source clk_{T0} is by default equal to the MCU clock, $clk_{I/O}$. When the AS0 bit in the ASSR Register is written to logic one, the clock source is taken from the Timer/Counter Oscillator connected to TOSC1 and TOSC2. For details on asynchronous operation, see “Asynchronous Status Register – ASSR” on page 106. For details on clock sources and prescaler, see “Timer/Counter Prescaler” on page 109.

Counter Unit

The main part of the 8-bit Timer/Counter is the programmable bi-directional counter unit. Figure 35 shows a block diagram of the counter and its surrounding environment.

Figure 35. Counter Unit Block Diagram



Signal description (internal signals):

| | |
|-------------------------|---|
| count | Increment or decrement TCNT0 by 1. |
| direction | Selects between increment and decrement. |
| clear | Clear TCNT0 (set all bits to zero). |
| clk_{T0} | Timer/Counter clock. |
| top | Signalizes that TCNT0 has reached maximum value. |
| bottom | Signalizes that TCNT0 has reached minimum value (zero). |

Depending on the mode of operation used, the counter is cleared, incremented, or decremented at each timer clock (clk_{T0}). clk_{T0} can be generated from an external or internal clock source, selected by the clock select bits (CS02:0). When no clock source is selected (CS02:0 = 0) the timer is stopped. However, the TCNT0 value can be accessed by the CPU, regardless of whether clk_{T0} is present or not. A CPU write overrides (has priority over) all counter clear or count operations.

The counting sequence is determined by the setting of the WGM01 and WGM00 bits located in the Timer/Counter Control Register (TCCR0). There are close connections between how the counter behaves (counts) and how waveforms are generated on the output compare output OC0. For more details about advanced counting sequences and waveform generation, see [“Modes of Operation” on page 97](#).

The Timer/Counter overflow (TOV0) flag is set according to the mode of operation selected by the WGM01:0 bits. TOV0 can be used for generating a CPU interrupt.

Output Compare Unit

The 8-bit comparator continuously compares TCNT0 with the Output Compare Register (OCR0). Whenever TCNT0 equals OCR0, the comparator signals a match. A match will set the output compare flag (OCF0) at the next timer clock cycle. If enabled (OCIE0 = 1), the output compare flag generates an output compare interrupt. The OCF0 flag is automatically cleared when the interrupt is executed. Alternatively, the OCF0 flag can be cleared by software by writing a logical one to its I/O bit location. The waveform generator uses the match signal to generate an output according to operating mode set by the WGM01:0 bits and compare output mode (COM01:0) bits. The max and bottom signals are used by the waveform generator for handling the special cases of the extreme values in some modes of operation ([“Modes of Operation” on page 97](#)). [Figure 36](#) shows a block diagram of the output compare unit.

Figure 36. Output Compare Unit, Block Diagram



The OCR0 Register is double buffered when using any of the Pulse Width Modulation (PWM) modes. For the normal and Clear Timer on Compare (CTC) modes of operation, the double buffering is disabled. The double buffering synchronizes the update of the OCR0 Compare Register to either top or bottom of the counting sequence. The synchronization prevents the occurrence of odd-length, non-symmetrical PWM pulses, thereby making the output glitch-free.

The OCR0 Register access may seem complex, but this is not case. When the double buffering is enabled, the CPU has access to the OCR0 buffer Register, and if double buffering is disabled the CPU will access the OCR0 directly.

Force Output Compare

In non-PWM waveform generation modes, the match output of the comparator can be forced by writing a one to the Force Output Compare (FOC0) bit. Forcing compare match will not set the OCF0 flag or reload/clear the timer, but the OC0 pin will be updated as if a real compare match had occurred (the COM01:0 bits settings define whether the OC0 pin is set, cleared or toggled).

Compare Match Blocking by TCNT0 Write

All CPU write operations to the TCNT0 Register will block any compare match that occurs in the next timer clock cycle, even when the timer is stopped. This feature allows OCR0 to be initialized to the same value as TCNT0 without triggering an interrupt when the Timer/Counter clock is enabled.

Using the Output Compare Unit

Since writing TCNT0 in any mode of operation will block all compare matches for one timer clock cycle, there are risks involved when changing TCNT0 when using the output compare channel, independently of whether the Timer/Counter is running or not. If the value written to TCNT0 equals the OCR0 value, the compare match will be missed, resulting in incorrect waveform generation. Similarly, do not write the TCNT0 value equal to BOTTOM when the counter is downcounting.

The setup of the OC0 should be performed before setting the Data Direction Register for the port pin to output. The easiest way of setting the OC0 value is to use the force output compare

(FOC0) strobe bit in normal mode. The OC0 Register keeps its value even when changing between waveform generation modes.

Be aware that the COM01:0 bits are not double buffered together with the compare value. Changing the COM01:0 bits will take effect immediately.

Compare Match Output Unit

The Compare Output mode (COM01:0) bits have two functions. The waveform generator uses the COM01:0 bits for defining the Output Compare (OC0) state at the next compare match. Also, the COM01:0 bits control the OC0 pin output source. [Figure 37](#) shows a simplified schematic of the logic affected by the COM01:0 bit setting. The I/O registers, I/O bits, and I/O pins in the figure are shown in bold. Only the parts of the General I/O Port Control Registers (DDR and PORT) that are affected by the COM01:0 bits are shown. When referring to the OC0 state, the reference is for the internal OC0 Register, not the OC0 pin.

Figure 37. Compare Match Output Unit, Schematic



The general I/O port function is overridden by the output compare (OC0) from the waveform generator if either of the COM01:0 bits are set. However, the OC0 pin direction (input or output) is still controlled by the Data Direction Register (DDR) for the port pin. The Data Direction Register bit for the OC0 pin (DDR_OC0) must be set as output before the OC0 value is visible on the pin. The port override function is independent of the waveform generation mode.

The design of the output compare pin logic allows initialization of the OC0 state before the output is enabled. Note that some COM01:0 bit settings are reserved for certain modes of operation. [See “8-bit Timer/Counter Register Description” on page 103.](#)

Compare Output Mode and Waveform Generation

The waveform generator uses the COM01:0 bits differently in normal, CTC, and PWM modes. For all modes, setting the COM01:0 = 0 tells the Waveform Generator that no action on the OC0 Register is to be performed on the next compare match. For compare output actions in the non-PWM modes refer to [Table 53 on page 104](#). For fast PWM mode, refer to [Table 54 on page 104](#), and for phase correct PWM refer to [Table 55 on page 105](#).

A change of the COM01:0 bits state will have effect at the first compare match after the bits are written. For non-PWM modes, the action can be forced to have immediate effect by using the FOC0 strobe bits.

Modes of Operation

The mode of operation, i.e., the behavior of the Timer/Counter and the output compare pins, is defined by the combination of the Waveform Generation mode (WGM01:0) and Compare Output mode (COM01:0) bits. The Compare Output mode bits do not affect the counting sequence, while the Waveform Generation mode bits do. The COM01:0 bits control whether the PWM output generated should be inverted or not (inverted or non-inverted PWM). For non-PWM modes the COM01:0 bits control whether the output should be set, cleared, or toggled at a compare match (See “Compare Match Output Unit” on page 96.).

For detailed timing information refer to “Timer/Counter Timing Diagrams” on page 101.

Normal Mode

The simplest mode of operation is the normal mode (WGM01:0 = 0). In this mode the counting direction is always up (incrementing), and no counter clear is performed. The counter simply overruns when it passes its maximum 8-bit value (TOP = 0xFF) and then restarts from the bottom (0x00). In normal operation the Timer/Counter overflow flag (TOV0) will be set in the same timer clock cycle as the TCNT0 becomes zero. The TOV0 flag in this case behaves like a ninth bit, except that it is only set, not cleared. However, combined with the timer overflow interrupt that automatically clears the TOV0 flag, the timer resolution can be increased by software. There are no special cases to consider in the normal mode, a new counter value can be written anytime.

The output compare unit can be used to generate interrupts at some given time. Using the output compare to generate waveforms in normal mode is not recommended, since this will occupy too much of the CPU time.

Clear Timer on Compare Match (CTC) Mode

In Clear Timer on Compare or CTC mode (WGM01:0 = 2), the OCR0 Register is used to manipulate the counter resolution. In CTC mode the counter is cleared to zero when the counter value (TCNT0) matches the OCR0. The OCR0 defines the top value for the counter, hence also its resolution. This mode allows greater control of the compare match output frequency. It also simplifies the operation of counting external events.

The timing diagram for the CTC mode is shown in Figure 38. The counter value (TCNT0) increases until a compare match occurs between TCNT0 and OCR0, and then counter (TCNT0) is cleared.

Figure 38. CTC Mode, Timing Diagram

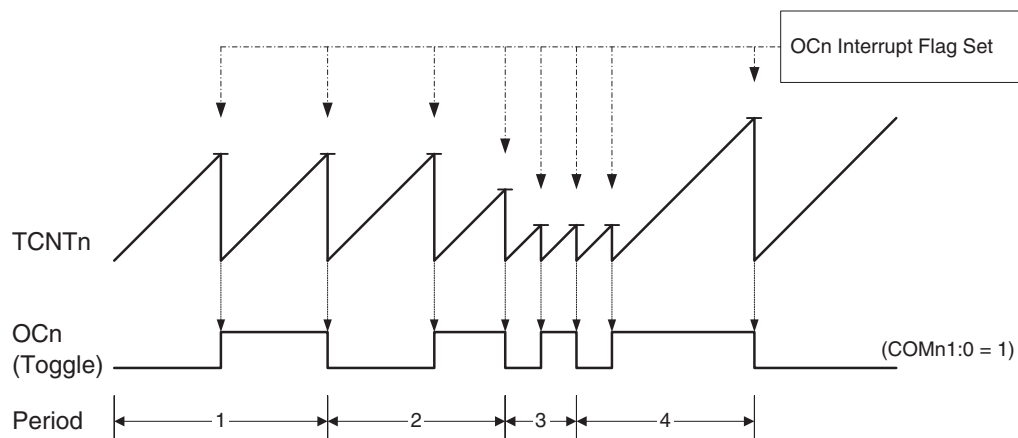

An interrupt can be generated each time the counter value reaches the TOP value by using the OCF0 flag. If the interrupt is enabled, the interrupt handler routine can be used for updating the TOP value. However, changing the TOP to a value close to BOTTOM when the counter is running with none or a low prescaler value must be done with care since the CTC mode does not have the double buffering feature. If the new value written to OCR0 is lower than the current

value of TCNT0, the counter will miss the compare match. The counter will then have to count to its maximum value (0xFF) and wrap around starting at 0x00 before the compare match can occur.

For generating a waveform output in CTC mode, the OC0 output can be set to toggle its logical level on each compare match by setting the Compare Output mode bits to Toggle mode (COM01:0 = 1). The OC0 value will not be visible on the port pin unless the data direction for the pin is set to output. The waveform generated will have a maximum frequency of $f_{OC0} = f_{clk_I/O}/2$ when OCR0 is set to zero (0x00). The waveform frequency is defined by the following equation:

$$f_{OCn} = \frac{f_{clk_I/O}}{2 \cdot N \cdot (1 + OCRn)}$$

The N variable represents the prescale factor (1, 8, 32, 64, 128, 256, or 1024).

As for the normal mode of operation, the TOV0 flag is set in the same timer clock cycle that the counter counts from MAX to 0x00.

Fast PWM Mode

The fast Pulse Width Modulation or fast PWM mode (WGM01:0 = 3) provides a high frequency PWM waveform generation option. The fast PWM differs from the other PWM option by its single-slope operation. The counter counts from BOTTOM to MAX then restarts from BOTTOM. In non-inverting Compare Output mode, the output compare (OC0) is cleared on the compare match between TCNT0 and OCR0, and set at BOTTOM. In inverting Compare Output mode, the output is set on compare match and cleared at BOTTOM. Due to the single-slope operation, the operating frequency of the fast PWM mode can be twice as high as the phase correct PWM mode that uses dual-slope operation. This high frequency makes the fast PWM mode well suited for power regulation, rectification, and DAC applications. High frequency allows physically small sized external components (coils, capacitors), and therefore reduces total system cost.

In fast PWM mode, the counter is incremented until the counter value matches the MAX value. The counter is then cleared at the following timer clock cycle. The timing diagram for the fast PWM mode is shown in [Figure 39](#). The TCNT0 value is in the timing diagram shown as a histogram for illustrating the single-slope operation. The diagram includes non-inverted and inverted PWM outputs. The small horizontal line marks on the TCNT0 slopes represent compare matches between OCR0 and TCNT0.

Figure 39. Fast PWM Mode, Timing Diagram



The Timer/Counter overflow flag (TOV0) is set each time the counter reaches Max. If the interrupt is enabled, the interrupt handler routine can be used for updating the compare value.

In fast PWM mode, the compare unit allows generation of PWM waveforms on the OC0 pin. Setting the COM01:0 bits to 2 will produce a non-inverted PWM and an inverted PWM output can be generated by setting the COM01:0 to 3 (See [Table 54 on page 104](#)). The actual OC0 value will only be visible on the port pin if the data direction for the port pin is set as output. The PWM waveform is generated by setting (or clearing) the OC0 Register at the compare match between OCR0 and TCNT0, and clearing (or setting) the OC0 Register at the timer clock cycle the counter is cleared (changes from MAX to BOTTOM).

The PWM frequency for the output can be calculated by the following equation:

$$f_{OCnPWM} = \frac{f_{clk_I/O}}{N \cdot 256}$$

The N variable represents the prescale factor (1, 8, 32, 64, 128, 256, or 1024).

The extreme values for the OCR0 Register represent special cases when generating a PWM waveform output in the fast PWM mode. If the OCR0 is set equal to BOTTOM, the output will be a narrow spike for each MAX+1 timer clock cycle. Setting the OCR0 equal to MAX will result in a constantly high or low output (depending on the polarity of the output set by the COM01:0 bits.)

A frequency (with 50% duty cycle) waveform output in fast PWM mode can be achieved by setting OC0 to toggle its logical level on each compare match (COM01:0 = 1). The waveform generated will have a maximum frequency of $f_{oc0} = f_{clk_I/O}/2$ when OCR0 is set to zero. This feature is similar to the OC0 toggle in CTC mode, except the double buffer feature of the output compare unit is enabled in the fast PWM mode.

Phase Correct PWM Mode

The phase correct PWM mode ($WGM01:0 = 1$) provides a high resolution phase correct PWM waveform generation option. The phase correct PWM mode is based on a dual-slope operation. The counter counts repeatedly from BOTTOM to MAX and then from MAX to BOTTOM. In non-inverting Compare Output mode, the output compare (OC0) is cleared on the compare match between TCNT0 and OCR0 while counting up, and set on the compare match while dncounting. In inverting Output Compare mode, the operation is inverted. The dual-slope operation has lower maximum operation frequency than single slope operation. However, due to the symmetric feature of the dual-slope PWM modes, these modes are preferred for motor control applications.

The PWM resolution for the phase correct PWM mode is fixed to 8 bits. In phase correct PWM mode the counter is incremented until the counter value matches Max. When the counter reaches MAX, it changes the count direction. The TCNT0 value will be equal to MAX for one timer clock cycle. The timing diagram for the phase correct PWM mode is shown on [Figure 40](#). The TCNT0 value is in the timing diagram shown as a histogram for illustrating the dual-slope operation. The diagram includes non-inverted and inverted PWM outputs. The small horizontal line marks on the TCNT0 slopes represent compare matches between OCR0 and TCNT0.

Figure 40. Phase Correct PWM Mode, Timing Diagram



The Timer/Counter Overflow Flag (TOV0) is set each time the counter reaches BOTTOM. The interrupt flag can be used to generate an interrupt each time the counter reaches the BOTTOM value.

In phase correct PWM mode, the compare unit allows generation of PWM waveforms on the OC0 pin. Setting the COM01:0 bits to 2 will produce a non-inverted PWM. An inverted PWM output can be generated by setting the COM01:0 to 3 (See [Table 55](#) on page 105). The actual OC0 value will only be visible on the port pin if the data direction for the port pin is set as output. The PWM waveform is generated by clearing (or setting) the OC0 Register at the compare match between OCR0 and TCNT0 when the counter increments, and setting (or clearing) the OC0 Register at compare match between OCR0 and TCNT0 when the counter decrements. The

PWM frequency for the output when using phase correct PWM can be calculated by the following equation:

$$f_{OCnPCPWM} = \frac{f_{clk_{I/O}}}{N \cdot 510}$$

The N variable represents the prescale factor (1, 8, 32, 64, 128, 256, or 1024).

The extreme values for the OCR0 Register represent special cases when generating a PWM waveform output in the phase correct PWM mode. If the OCR0 is set equal to BOTTOM, the output will be continuously low and if set equal to MAX the output will be continuously high for non-inverted PWM mode. For inverted PWM the output will have the opposite logic values.

At the very start of Period 2 in [Figure 40](#) OCn has a transition from high to low even though there is no Compare Match. The point of this transition is to guarantee symmetry around BOTTOM. There are two cases that give a transition without Compare Match:

- OCR0 changes its value from MAX, like in [Figure 40](#). When the OCR0 value is MAX the OCn pin value is the same as the result of a down-counting Compare Match. To ensure symmetry around BOTTOM the OCn value at MAX must correspond to the result of an up-counting Compare Match.
- The timer starts counting from a higher value than the one in OCR0, and for that reason misses the Compare Match and hence the OCn change that would have happened on the way up.

Timer/Counter Timing Diagrams

[Figure 41](#) and [Figure 42](#) contain timing data for the Timer/Counter operation. The Timer/Counter is a synchronous design and the timer clock (clk_{Tn}) is therefore shown as a clock enable signal. The figure shows the count sequence close to the MAX value. [Figure 43](#) and [Figure 44](#) show the same timing data, but with the prescaler enabled. The figures illustrate when interrupt flags are set.

The following figures show the Timer/Counter in Synchronous mode, and the timer clock (clk_{Tn}) is therefore shown as a clock enable signal. In asynchronous mode, $clk_{I/O}$ should be replaced by the Timer/Counter Oscillator clock. The figures include information on when interrupt flags are set. [Figure 41](#) contains timing data for basic Timer/Counter operation. The figure shows the count sequence close to the MAX value in all modes other than phase correct PWM mode.

Figure 41. Timer/Counter Timing Diagram, No Prescaling



[Figure 42](#) shows the same timing data, but with the prescaler enabled.

Figure 42. Timer/Counter Timing Diagram, with Prescaler ($f_{clk_I/O}/8$)



Figure 43 shows the setting of OCF0 in all modes except CTC mode.

Figure 43. Timer/Counter Timing Diagram, Setting of OCF0, with Prescaler ($f_{clk_I/O}/8$)



Figure 44 shows the setting of OCF0 and the clearing of TCNT0 in CTC mode.

Figure 44. Timer/Counter Timing Diagram, Clear Timer on Compare Match Mode, with Prescaler ($f_{clk_I/O}/8$)

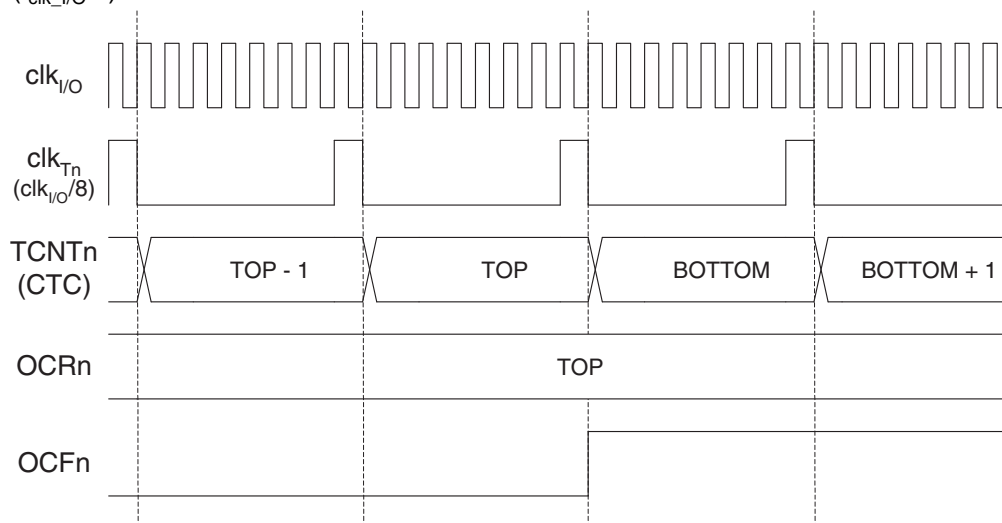

8-bit Timer/Counter Register Description

Timer/Counter Control Register – TCCR0

| Bit | 7 | 6 | 5 | 4 | 3 | 2 | 1 | 0 | |
|---------------|-------------|--------------|--------------|--------------|--------------|-------------|-------------|-------------|--------------|
| | FOC0 | WGM00 | COM01 | COM00 | WGM01 | CS02 | CS01 | CS00 | TCCR0 |
| Read/Write | W | R/W | R/W | R/W | R/W | R/W | R/W | R/W | |
| Initial Value | 0 | 0 | 0 | 0 | 0 | 0 | 0 | 0 | |

- **Bit 7 – FOC0: Force Output Compare**

The FOC0 bit is only active when the WGM bits specify a non-PWM mode. However, for ensuring compatibility with future devices, this bit must be set to zero when TCCR0 is written when operating in PWM mode. When writing a logical one to the FOC0 bit, an immediate compare match is forced on the waveform generation unit. The OC0 output is changed according to its COM01:0 bits setting. Note that the FOC0 bit is implemented as a strobe. Therefore it is the value present in the COM01:0 bits that determines the effect of the forced compare.

A FOC0 strobe will not generate any interrupt, nor will it clear the timer in CTC mode using OCR0 as TOP.

The FOC0 bit is always read as zero.

- **Bit 6, 3 – WGM01:0: Waveform Generation Mode**

These bits control the counting sequence of the counter, the source for the maximum (TOP) counter value, and what type of waveform generation to be used. Modes of operation supported by the Timer/Counter unit are: Normal mode, Clear Timer on Compare match (CTC) mode, and two types of Pulse Width Modulation (PWM) modes. See [Table 52](#) and “Modes of Operation” on [page 97](#).

Table 52. Waveform Generation Mode Bit Description

| Mode | WGM01 ⁽¹⁾ (CTC0) | WGM00 ⁽¹⁾ (PWM0) | Timer/Counter Mode of Operation | TOP | Update of OCR0 at | TOV0 Flag Set on |
|------|--------------------------------|--------------------------------|------------------------------------|------|----------------------|---------------------|
| 0 | 0 | 0 | Normal | 0xFF | Immediate | MAX |
| 1 | 0 | 1 | PWM, Phase Correct | 0xFF | TOP | BOTTOM |
| 2 | 1 | 0 | CTC | OCR0 | Immediate | MAX |
| 3 | 1 | 1 | Fast PWM | 0xFF | BOTTOM | MAX |

Note: 1. The CTC0 and PWM0 bit definition names are now obsolete. Use the WGM01:0 definitions. However, the functionality and location of these bits are compatible with previous versions of the timer.

• **Bit 5:4 – COM01:0: Compare Match Output Mode**

These bits control the output compare pin (OC0) behavior. If one or both of the COM01:0 bits are set, the OC0 output overrides the normal port functionality of the I/O pin it is connected to. However, note that the Data Direction Register (DDR) bit corresponding to OC0 pin must be set in order to enable the output driver.

When OC0 is connected to the pin, the function of the COM01:0 bits depends on the WGM01:0 bit setting. [Table 53](#) shows the COM01:0 bit functionality when the WGM01:0 bits are set to a normal or CTC mode (non-PWM).

Table 53. Compare Output Mode, non-PWM Mode

| COM01 | COM00 | Description |
|-------|-------|--|
| 0 | 0 | Normal port operation, OC0 disconnected. |
| 0 | 1 | Toggle OC0 on compare match |
| 1 | 0 | Clear OC0 on compare match |
| 1 | 1 | Set OC0 on compare match |

[Table 54](#) shows the COM01:0 bit functionality when the WGM01:0 bits are set to fast PWM mode.

Table 54. Compare Output Mode, Fast PWM Mode⁽¹⁾

| COM01 | COM00 | Description |
|-------|-------|---|
| 0 | 0 | Normal port operation, OC0 disconnected. |
| 0 | 1 | Reserved |
| 1 | 0 | Clear OC0 on compare match, set OC0 at BOTTOM, (non-inverting mode) |
| 1 | 1 | Set OC0 on compare match, clear OC0 at BOTTOM, (inverting mode) |

Note: 1. A special case occurs when OCR0 equals TOP and COM01 is set. In this case, the compare match is ignored, but the set or clear is done at BOTTOM. See “Fast PWM Mode” on page 98 for more details.

[Table 55](#) shows the COM01:0 bit functionality when the WGM01:0 bits are set to phase correct PWM mode.

Table 55. Compare Output Mode, Phase Correct PWM Mode⁽¹⁾

| COM01 | COM00 | Description |
|-------|-------|--|
| 0 | 0 | Normal port operation, OC0 disconnected. |
| 0 | 1 | Reserved |
| 1 | 0 | Clear OC0 on compare match when up-counting. Set OC0 on compare match when downcounting. |
| 1 | 1 | Set OC0 on compare match when up-counting. Clear OC0 on compare match when downcounting. |

Note: 1. A special case occurs when OCR0 equals TOP and COM01 is set. In this case, the compare match is ignored, but the set or clear is done at TOP. See “Phase Correct PWM Mode” on page 100 for more details.

• **Bit 2:0 – CS02:0: Clock Select**

The three clock select bits select the clock source to be used by the Timer/Counter, see Table 56.

Table 56. Clock Select Bit Description

| CS02 | CS01 | CS00 | Description |
|------|------|------|---|
| 0 | 0 | 0 | No clock source (Timer/Counter stopped) |
| 0 | 0 | 1 | clk _{T0S} /(No prescaling) |
| 0 | 1 | 0 | clk _{T0S} /8 (From prescaler) |
| 0 | 1 | 1 | clk _{T0S} /32 (From prescaler) |
| 1 | 0 | 0 | clk _{T0S} /64 (From prescaler) |
| 1 | 0 | 1 | clk _{T0S} /128 (From prescaler) |
| 1 | 1 | 0 | clk _{T0S} /256 (From prescaler) |
| 1 | 1 | 1 | clk _{T0S} /1024 (From prescaler) |

Timer/Counter Register – TCNT0

| | | | | | | | | | |
|---------------|-------------------|-----|-----|-----|-----|-----|-----|-----|--------------|
| Bit | 7 | 6 | 5 | 4 | 3 | 2 | 1 | 0 | |
| | TCNT0[7:0] | | | | | | | | TCNT0 |
| Read/Write | R/W | R/W | R/W | R/W | R/W | R/W | R/W | R/W | |
| Initial Value | 0 | 0 | 0 | 0 | 0 | 0 | 0 | 0 | |

The Timer/Counter Register gives direct access, both for read and write operations, to the Timer/Counter unit 8-bit counter. Writing to the TCNT0 Register blocks (removes) the compare match on the following timer clock. Modifying the counter (TCNT0) while the counter is running, introduces a risk of missing a compare match between TCNT0 and the OCR0 Register.

Output Compare Register – OCR0

| | | | | | | | | | |
|---------------|------------------|-----|-----|-----|-----|-----|-----|-----|-------------|
| Bit | 7 | 6 | 5 | 4 | 3 | 2 | 1 | 0 | |
| | OCR0[7:0] | | | | | | | | OCR0 |
| Read/Write | R/W | R/W | R/W | R/W | R/W | R/W | R/W | R/W | |
| Initial Value | 0 | 0 | 0 | 0 | 0 | 0 | 0 | 0 | |

The Output Compare Register contains an 8-bit value that is continuously compared with the counter value (TCNT0). A match can be used to generate an output compare interrupt, or to generate a waveform output on the OC0 pin.



Asynchronous Operation of the Timer/Counter

Asynchronous Status Register – ASSR

| | | | | | | | | | |
|---------------|---|---|---|---|-----|--------|--------|--------|------|
| Bit | 7 | 6 | 5 | 4 | 3 | 2 | 1 | 0 | |
| | – | – | – | – | AS0 | TCN0UB | OCR0UB | TCR0UB | ASSR |
| Read/Write | R | R | R | R | R/W | R | R | R | |
| Initial Value | 0 | 0 | 0 | 0 | 0 | 0 | 0 | 0 | |

- **Bit 3 – AS0: Asynchronous Timer/Counter0**

When AS0 is written to zero, Timer/Counter0 is clocked from the I/O clock, $clk_{I/O}$. When AS0 is written to one, Timer/Counter is clocked from a crystal Oscillator connected to the Timer Oscillator 1 (TOSC1) pin. When the value of AS0 is changed, the contents of TCNT0, OCR0, and TCCR0 might be corrupted.

- **Bit 2 – TCN0UB: Timer/Counter0 Update Busy**

When Timer/Counter0 operates asynchronously and TCNT0 is written, this bit becomes set. When TCNT0 has been updated from the temporary storage register, this bit is cleared by hardware. A logical zero in this bit indicates that TCNT0 is ready to be updated with a new value.

- **Bit 1 – OCR0UB: Output Compare Register0 Update Busy**

When Timer/Counter0 operates asynchronously and OCR0 is written, this bit becomes set. When OCR0 has been updated from the temporary storage register, this bit is cleared by hardware. A logical zero in this bit indicates that OCR0 is ready to be updated with a new value.

- **Bit 0 – TCR0UB: Timer/Counter Control Register0 Update Busy**

When Timer/Counter0 operates asynchronously and TCCR0 is written, this bit becomes set. When TCCR0 has been updated from the temporary storage register, this bit is cleared by hardware. A logical zero in this bit indicates that TCCR0 is ready to be updated with a new value.

If a write is performed to any of the three Timer/Counter0 Registers while its update busy flag is set, the updated value might get corrupted and cause an unintentional interrupt to occur.

The mechanisms for reading TCNT0, OCR0, and TCCR0 are different. When reading TCNT0, the actual timer value is read. When reading OCR0 or TCCR0, the value in the temporary storage register is read.

Asynchronous Operation of Timer/Counter0

When Timer/Counter0 operates asynchronously, some considerations must be taken.

- **Warning:** When switching between asynchronous and synchronous clocking of Timer/Counter0, the Timer Registers TCNT0, OCR0, and TCCR0 might be corrupted. A safe procedure for switching clock source is:
 1. Disable the Timer/Counter0 interrupts by clearing OCIE0 and TOIE0.
 2. Select clock source by setting AS0 as appropriate.
 3. Write new values to TCNT0, OCR0, and TCCR0.
 4. To switch to asynchronous operation: Wait for TCN0UB, OCR0UB, and TCR0UB.
 5. Clear the Timer/Counter0 interrupt flags.
 6. Enable interrupts, if needed.
- The Oscillator is optimized for use with a 32.768 kHz watch crystal. Applying an external clock to the TOSC1 pin may result in incorrect Timer/Counter0 operation. The CPU main clock frequency must be more than four times the Oscillator frequency.

- When writing to one of the registers TCNT0, OCR0, or TCCR0, the value is transferred to a temporary register, and latched after two positive edges on TOSC1. The user should not write a new value before the contents of the Temporary Register have been transferred to its destination. Each of the three mentioned registers have their individual temporary register, which means that e.g., writing to TCNT0 does not disturb an OCR0 write in progress. To detect that a transfer to the destination register has taken place, the Asynchronous Status Register – ASSR has been implemented.
- When entering Power-save or Extended Standby mode after having written to TCNT0, OCR0, or TCCR0, the user must wait until the written register has been updated if Timer/Counter0 is used to wake up the device. Otherwise, the MCU will enter sleep mode before the changes are effective. This is particularly important if the Output Compare0 interrupt is used to wake up the device, since the output compare function is disabled during writing to OCR0 or TCNT0. If the write cycle is not finished, and the MCU enters sleep mode before the OCR0UB bit returns to zero, the device will never receive a compare match interrupt, and the MCU will not wake up.
- If Timer/Counter0 is used to wake the device up from Power-save or Extended Standby mode, precautions must be taken if the user wants to re-enter one of these modes: The interrupt logic needs one TOSC1 cycle to be reset. If the time between wake-up and re-entering sleep mode is less than one TOSC1 cycle, the interrupt will not occur, and the device will fail to wake up. If the user is in doubt whether the time before re-entering Power-save or Extended Standby mode is sufficient, the following algorithm can be used to ensure that one TOSC1 cycle has elapsed:
 1. Write a value to TCCR0, TCNT0, or OCR0.
 2. Wait until the corresponding Update Busy flag in ASSR returns to zero.
 3. Enter Power-save or Extended Standby mode.
- When the asynchronous operation is selected, the 32.768kHz Oscillator for Timer/Counter0 is always running, except in Power-down and Standby modes. After a Power-up Reset or wake-up from Power-down or Standby mode, the user should be aware of the fact that this Oscillator might take as long as one second to stabilize. The user is advised to wait for at least one second before using Timer/Counter0 after power-up or wake-up from Power-down or Standby mode. The contents of all Timer/Counter0 Registers must be considered lost after a wake-up from Power-down or Standby mode due to unstable clock signal upon start-up, no matter whether the Oscillator is in use or a clock signal is applied to the TOSC1 pin.
- Description of wake up from Power-save or Extended Standby mode when the timer is clocked asynchronously: When the interrupt condition is met, the wake up process is started on the following cycle of the timer clock, that is, the timer is always advanced by at least one before the processor can read the counter value. After wake-up, the MCU is halted for four cycles, it executes the interrupt routine, and resumes execution from the instruction following SLEEP.
- Reading of the TCNT0 Register shortly after wake-up from Power-save may give an incorrect result. Since TCNT0 is clocked on the asynchronous TOSC clock, reading TCNT0 must be done through a register synchronized to the internal I/O clock domain. Synchronization takes place for every rising TOSC1 edge. When waking up from Power-save mode, and the I/O clock ($clk_{I/O}$) again becomes active, TCNT0 will read as the previous value (before entering sleep) until the next rising TOSC1 edge. The phase of the TOSC clock after waking up from Power-save mode is essentially unpredictable, as it depends on the wake-up time. The recommended procedure for reading TCNT0 is thus as follows:
 1. Write any value to either of the registers OCR0 or TCCR0.
 2. Wait for the corresponding Update Busy Flag to be cleared.
 3. Read TCNT0.

- During asynchronous operation, the synchronization of the interrupt flags for the asynchronous timer takes three processor cycles plus one timer cycle. The timer is therefore advanced by at least one before the processor can read the timer value causing the setting of the interrupt flag. The output compare pin is changed on the timer clock and is not synchronized to the processor clock.

Timer/Counter Interrupt Mask Register – TIMSK

| Bit | 7 | 6 | 5 | 4 | 3 | 2 | 1 | 0 | |
|---------------|-------|-------|--------|--------|--------|-------|-------|-------|-------|
| | OCIE2 | TOIE2 | TICIE1 | OCIE1A | OCIE1B | TOIE1 | OCIE0 | TOIE0 | TIMSK |
| Read/Write | R/W | R/W | R/W | R/W | R/W | R/W | R/W | R/W | |
| Initial Value | 0 | 0 | 0 | 0 | 0 | 0 | 0 | 0 | |

- **Bit 1 – OCIE0: Timer/Counter0 Output Compare Match Interrupt Enable**

When the OCIE0 bit is written to one, and the I-bit in the Status Register is set (one), the Timer/Counter0 Compare Match interrupt is enabled. The corresponding interrupt is executed if a compare match in Timer/Counter0 occurs, i.e., when the OCF0 bit is set in the Timer/Counter Interrupt Flag Register – TIFR.

- **Bit 0 – TOIE0: Timer/Counter0 Overflow Interrupt Enable**

When the TOIE0 bit is written to one, and the I-bit in the Status Register is set (one), the Timer/Counter0 Overflow interrupt is enabled. The corresponding interrupt is executed if an overflow in Timer/Counter0 occurs, i.e., when the TOV0 bit is set in the Timer/Counter Interrupt Flag Register – TIFR.

Timer/Counter Interrupt Flag Register – TIFR

| Bit | 7 | 6 | 5 | 4 | 3 | 2 | 1 | 0 | |
|---------------|------|------|------|-------|-------|------|------|------|------|
| | OCF2 | TOV2 | ICF1 | OCF1A | OCF1B | TOV1 | OCF0 | TOV0 | TIFR |
| Read/Write | R/W | R/W | R/W | R/W | R/W | R/W | R/W | R/W | |
| Initial Value | 0 | 0 | 0 | 0 | 0 | 0 | 0 | 0 | |

- **Bit 1 – OCF0: Output Compare Flag 0**

The OCF0 bit is set (one) when a compare match occurs between the Timer/Counter0 and the data in OCR0 – Output Compare Register0. OCF0 is cleared by hardware when executing the corresponding interrupt handling vector. Alternatively, OCF0 is cleared by writing a logic one to the flag. When the I-bit in SREG, OCIE0 (Timer/Counter0 Compare Match Interrupt Enable), and OCF0 are set (one), the Timer/Counter0 Compare Match Interrupt is executed.

- **Bit 0 – TOV0: Timer/Counter0 Overflow Flag**

The bit TOV0 is set (one) when an overflow occurs in Timer/Counter0. TOV0 is cleared by hardware when executing the corresponding interrupt handling vector. Alternatively, TOV0 is cleared by writing a logic one to the flag. When the SREG I-bit, TOIE0 (Timer/Counter0 Overflow Interrupt Enable), and TOV0 are set (one), the Timer/Counter0 Overflow Interrupt is executed. In PWM mode, this bit is set when Timer/Counter0 changes counting direction at \$00.

Timer/Counter Prescaler

Figure 45. Prescaler for Timer/Counter0



The clock source for Timer/Counter0 is named clk_{T0} . clk_{T0} is by default connected to the main system clock $clk_{I/O}$. By setting the AS0 bit in ASSR, Timer/Counter0 is asynchronously clocked from the TOSC1 pin. This enables use of Timer/Counter0 as a Real Time Counter (RTC). When AS0 is set, pins TOSC1 and TOSC2 are disconnected from Port C. A crystal can then be connected between the TOSC1 and TOSC2 pins to serve as an independent clock source for Timer/Counter0. The Oscillator is optimized for use with a 32.768kHz crystal. Applying an external clock source to TOSC1 is not recommended.

For Timer/Counter0, the possible prescaled selections are: $clk_{T0S}/8$, $clk_{T0S}/32$, $clk_{T0S}/64$, $clk_{T0S}/128$, $clk_{T0S}/256$, and $clk_{T0S}/1024$. Additionally, clk_{T0S} as well as 0 (stop) may be selected. Setting the PSR0 bit in SFIOR resets the prescaler. This allows the user to operate with a predictable prescaler.

Special Function IO Register – SFIOR

| Bit | 7 | 6 | 5 | 4 | 3 | 2 | 1 | 0 | |
|---------------|------------|---|---|---|-------------|------------|-------------|---------------|-------|
| | TSM | – | – | – | ACME | PUD | PSR0 | PSR321 | SFIOR |
| Read/Write | R/W | R | R | R | R/W | R/W | R/W | R/W | |
| Initial Value | 0 | 0 | 0 | 0 | 0 | 0 | 0 | 0 | |

• Bit 7 – TSM: Timer/Counter Synchronization Mode

Writing the TSM bit to one activates the Timer/Counter Synchronization mode. In this mode, the value that is written to the PSR0 and PSR321 bits is kept, hence keeping the corresponding prescaler reset signals asserted. This ensures that the corresponding Timer/Counters are halted and can be configured to the same value without the risk of one of them advancing during configuration. When the TSM bit is written to zero, the PSR0 and PSR321 bits are cleared by hardware, and the Timer/Counters start counting simultaneously.

- **Bit 1 – PSR0: Prescaler Reset Timer/Counter0**

When this bit is one, the Timer/Counter0 prescaler will be reset. This bit is normally cleared immediately by hardware. If this bit is written when Timer/Counter0 is operating in asynchronous mode, the bit will remain one until the prescaler has been reset. The bit will not be cleared by hardware if the TSM bit is set.

16-bit Timer/Counter (Timer/Counter 1 and Timer/Counter3)

The 16-bit Timer/Counter unit allows accurate program execution timing (event management), wave generation, and signal timing measurement. The main features are:

- **True 16-bit Design (i.e., Allows 16-bit PWM)**
- **Three Independent Output Compare Units**
- **Double Buffered Output Compare Registers**
- **One Input Capture Unit**
- **Input Capture Noise Canceler**
- **Clear Timer on Compare Match (Auto Reload)**
- **Glitch-free, Phase Correct Pulse width Modulator (PWM)**
- **Variable PWM Period**
- **Frequency Generator**
- **External Event Counter**
- **Ten Independent Interrupt Sources (TOV1, OCF1A, OCF1B, OCF1C, ICF1, TOV3, OCF3A, OCF3B, OCF3C, and ICF3)**

Restrictions in ATmega103 Compatibility Mode

Note that in Atmel® AVR® ATmega103 compatibility mode, only one 16-bit Timer/Counter is available (Timer/Counter1). Also note that in ATmega103 compatibility mode, the Timer/Counter1 has two Compare Registers (Compare A and Compare B) only.

Overview

Most register and bit references in this section are written in general form. A lower case “n” replaces the Timer/Counter number, and a lower case “x” replaces the Output Compare unit channel. However, when using the register or bit defines in a program, the precise form must be used i.e., TCNT1 for accessing Timer/Counter1 counter value and so on.

A simplified block diagram of the 16-bit Timer/Counter is shown in [Figure 46](#). For the actual placement of I/O pins, refer to [“Pin Configurations” on page 2](#). CPU accessible I/O Registers, including I/O bits and I/O pins, are shown in bold. The device-specific I/O Register and bit locations are listed in the [“16-bit Timer/Counter Register Description” on page 132](#).

Figure 46. 16-bit Timer/Counter Block Diagram



Note: Refer to [Figure 1 on page 2](#), [Table 30 on page 73](#), and [Table 39 on page 80](#) for Timer/Counter1 and 3 pin placement and description.

Registers

The *Timer/Counter* (TCNTn), *Output Compare Registers* (OCRnA/B/C), and *Input Capture Register* (ICRn) are all 16-bit registers. Special procedures must be followed when accessing the 16-bit registers. These procedures are described in the section [“Accessing 16-bit Registers” on page 114](#). The *Timer/Counter Control Registers* (TCCRnA/B/C) are 8-bit registers and have no CPU access restrictions. Interrupt requests (shortened as Int.Req.) signals are all visible in the *Timer Interrupt Flag Register* (TIFR) and *Extended Timer Interrupt Flag Register* (ETIFR). All interrupts are individually masked with the *Timer Interrupt Mask Register* (TIMSK) and *Extended Timer Interrupt Mask Register* (ETIMSK). (E)TIFR and (E)TIMSK are not shown in the figure since these registers are shared by other timer units.

The Timer/Counter can be clocked internally, via the prescaler, or by an external clock source on the Tn pin. The Clock Select logic block controls which clock source and edge the Timer/Counter uses to increment (or decrement) its value. The Timer/Counter is inactive when no clock source is selected. The output from the clock select logic is referred to as the timer clock (clk_{Tn}).

The double buffered Output Compare Registers (OCRnA/B/C) are compared with the Timer/Counter value at all time. The result of the compare can be used by the waveform generator to generate a PWM or variable frequency output on the Output Compare Pin (OCnA/B/C).

See “Output Compare Units” on page 120.. The compare match event will also set the compare match flag (OCFnA/B/C) which can be used to generate an output compare interrupt request.

The Input Capture Register can capture the Timer/Counter value at a given external (edge triggered) event on either the Input Capture Pin (ICPn) or on the Analog Comparator pins (See “Analog Comparator” on page 227.) The Input Capture unit includes a digital filtering unit (Noise Canceler) for reducing the chance of capturing noise spikes.

The TOP value, or maximum Timer/Counter value, can in some modes of operation be defined by either the OCRnA Register, the ICRn Register, or by a set of fixed values. When using OCRnA as TOP value in a PWM mode, the OCRnA Register can not be used for generating a PWM output. However, the TOP value will in this case be double buffered allowing the TOP value to be changed in run time. If a fixed TOP value is required, the ICRn Register can be used as an alternative, freeing the OCRnA to be used as PWM output.

Definitions

The following definitions are used extensively throughout the document:

Table 57. Definitions

| | |
|--------|--|
| BOTTOM | The counter reaches the <i>BOTTOM</i> when it becomes 0x0000. |
| MAX | The counter reaches its <i>MAX</i> imum when it becomes 0xFFFF (decimal 65535). |
| TOP | The counter reaches the <i>TOP</i> when it becomes equal to the highest value in the count sequence. The TOP value can be assigned to be one of the fixed values: 0x00FF, 0x01FF, or 0x03FF, or to the value stored in the OCRnA or ICRn Register. The assignment is dependent of the mode of operation. |

Compatibility

The 16-bit Timer/Counter has been updated and improved from previous versions of the 16-bit AVR Timer/Counter. This 16-bit Timer/Counter is fully compatible with the earlier version regarding:

- All 16-bit Timer/Counter related I/O register address locations, including timer interrupt registers.
- Bit locations inside all 16-bit Timer/Counter Registers, including Timer Interrupt Registers.
- Interrupt vectors.

The following control bits have changed name, but have same functionality and register location:

- PWMn0 is changed to WGMn0.
- PWMn1 is changed to WGMn1.
- CTCn is changed to WGMn2.

The following registers are added to the 16-bit Timer/Counter:

- Timer/Counter Control Register C (TCCRnC).
- Output Compare Register C, OCRnCH and OCRnCL, combined OCRnC.

The following bits are added to the 16-bit Timer/Counter Control Registers:

- COM1C1:0 are added to TCCR1A.
- FOCnA, FOCnB, and FOCnC are added in the new TCCRnC Register.
- WGMn3 is added to TCCRnB.

Interrupt flag and mask bits for output compare unit C are added.

The 16-bit Timer/Counter has improvements that will affect the compatibility in some special cases.

Accessing 16-bit Registers

The TCNTn, OCRnA/B/C, and ICRn are 16-bit registers that can be accessed by the AVR CPU via the 8-bit data bus. The 16-bit register must be byte accessed using two read or write operations. Each 16-bit timer has a single 8-bit register for temporary storing of the high byte of the 16-bit access. The same Temporary Register is shared between all 16-bit registers within each 16-bit timer. Accessing the low byte triggers the 16-bit read or write operation. When the low byte of a 16-bit register is written by the CPU, the high byte stored in the Temporary Register, and the low byte written are both copied into the 16-bit register in the same clock cycle. When the low byte of a 16-bit register is read by the CPU, the high byte of the 16-bit register is copied into the Temporary Register in the same clock cycle as the low byte is read.

Not all 16-bit accesses uses the Temporary Register for the high byte. Reading the OCRnA/B/C 16-bit registers does not involve using the Temporary Register.

To do a 16-bit write, *the high byte must be written before the low byte*. For a 16-bit read, *the low byte must be read before the high byte*.

The following code examples show how to access the 16-bit timer registers assuming that no interrupts updates the temporary register. The same principle can be used directly for accessing the OCRnA/B/C and ICRn Registers. Note that when using “C”, the compiler handles the 16-bit access.

Assembly Code Examples⁽¹⁾

```

...
; Set TCNTn to 0x01FF
ldi r17,0x01
ldi r16,0xFF
out TCNTnH,r17
out TCNTnL,r16
; Read TCNTn into r17:r16
in r16,TCNTnL
in r17,TCNTnH
...

```

C Code Examples⁽¹⁾

```

unsigned int i;
...
/* Set TCNTn to 0x01FF */
TCNTn = 0x1FF;
/* Read TCNTn into i */
i = TCNTn;
...

```

Note: 1. See “About Code Examples” on page 8.

The assembly code example returns the TCNTn value in the r17:r16 register pair.

It is important to notice that accessing 16-bit registers are atomic operations. If an interrupt occurs between the two instructions accessing the 16-bit register, and the interrupt code updates the temporary register by accessing the same or any other of the 16-bit Timer Registers, then the result of the access outside the interrupt will be corrupted. Therefore, when both the main code and the interrupt code update the temporary register, the main code must disable the interrupts during the 16-bit access.

The following code examples show how to do an atomic read of the TCNTn Register contents. Reading any of the OCRnA/B/C or ICRn Registers can be done by using the same principle.

Assembly Code Example⁽¹⁾

```
TIM16_ReadTCNTn:
    ; Save global interrupt flag
    in r18,SREG
    ; Disable interrupts
    cli
    ; Read TCNTn into r17:r16
    in r16,TCNTnL
    in r17,TCNTnH
    ; Restore global interrupt flag
    out SREG,r18
    ret
```

C Code Example⁽¹⁾

```
unsigned int TIM16_ReadTCNTn( void )
{
    unsigned char sreg;
    unsigned int i;
    /* Save global interrupt flag */
    sreg = SREG;
    /* Disable interrupts */
    __disable_interrupt();
    /* Read TCNTn into i */
    i = TCNTn;
    /* Restore global interrupt flag */
    SREG = sreg;
    return i;
}
```

Note: 1. See “About Code Examples” on page 8.

The assembly code example returns the TCNTn value in the r17:r16 register pair.

The following code examples show how to do an atomic write of the TCNTn Register contents. Writing any of the OCRnA/B/C or ICRn Registers can be done by using the same principle.

Assembly Code Example⁽¹⁾

```
TIM16_WriteTCNTn:
    ; Save global interrupt flag
    in r18,SREG
    ; Disable interrupts
    cli
    ; Set TCNTn to r17:r16
    out TCNTnH,r17
    out TCNTnL,r16
    ; Restore global interrupt flag
    out SREG,r18
    ret
```

C Code Example⁽¹⁾

```
void TIM16_WriteTCNTn( unsigned int i )
{
    unsigned char sreg;
    unsigned int i;
    /* Save global interrupt flag */
    sreg = SREG;
    /* Disable interrupts */
    __disable_interrupt();
    /* Set TCNTn to i */
    TCNTn = i;
    /* Restore global interrupt flag */
    SREG = sreg;
}
```

Note: 1. See “About Code Examples” on page 8.
The assembly code example requires that the r17:r16 register pair contains the value to be written to TCNTn.

Reusing the Temporary High Byte Register

If writing to more than one 16-bit register where the high byte is the same for all registers written, then the high byte only needs to be written once. However, note that the same rule of atomic operation described previously also applies in this case.

Timer/Counter Clock Sources

The Timer/Counter can be clocked by an internal or an external clock source. The clock source is selected by the clock select logic which is controlled by the *Clock Select* (CSn2:0) bits located in the *Timer/Counter Control Register B* (TCCRnB). For details on clock sources and prescaler, see “[Timer/Counter3, Timer/Counter2, and Timer/Counter1 Prescalers](#)” on page 143.

Counter Unit

The main part of the 16-bit Timer/Counter is the programmable 16-bit bi-directional counter unit. [Figure 47](#) shows a block diagram of the counter and its surroundings.

Figure 47. Counter Unit Block Diagram

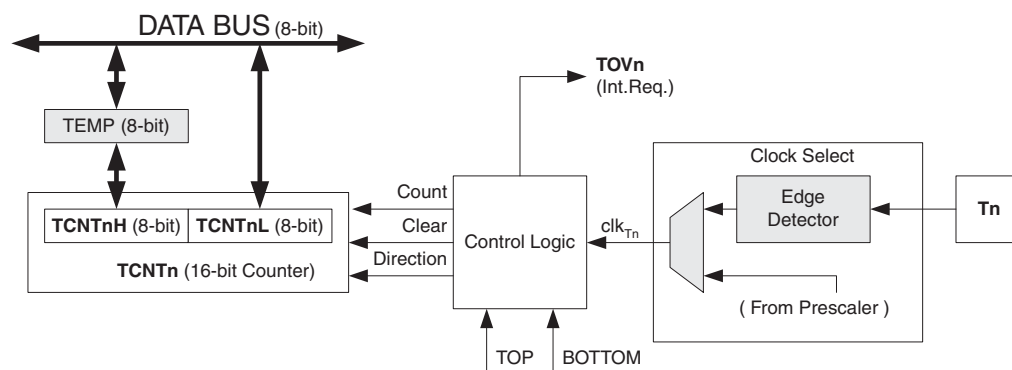

Signal description (internal signals):

- Count** Increment or decrement TCNTn by 1.
- Direction** Select between increment and decrement.
- Clear** Clear TCNTn (set all bits to zero).
- clk_{Tn}** Timer/Counter clock.
- TOP** Signalize that TCNTn has reached maximum value.
- BOTTOM** Signalize that TCNTn has reached minimum value (zero).

The 16-bit counter is mapped into two 8-bit I/O memory locations: *Counter High* (TCNTnH) containing the upper 8-bits of the counter, and *Counter Low* (TCNTnL) containing the lower 8-bits. The TCNTnH Register can only be indirectly accessed by the CPU. When the CPU does an access to the TCNTnH I/O location, the CPU accesses the high byte Temporary Register (TEMP). The Temporary Register is updated with the TCNTnH value when the TCNTnL is read, and TCNTnH is updated with the Temporary Register value when TCNTnL is written. This allows the CPU to read or write the entire 16-bit counter value within one clock cycle via the 8-bit data bus. It is important to notice that there are special cases of writing to the TCNTn Register when the counter is counting that will give unpredictable results. The special cases are described in the sections where they are of importance.

Depending on the mode of operation used, the counter is cleared, incremented, or decremented at each *Timer Clock* (clk_{Tn}). The clk_{Tn} can be generated from an external or internal clock source, selected by the *Clock Select* bits (CSn2:0). When no clock source is selected (CSn2:0 = 0) the timer is stopped. However, the TCNTn value can be accessed by the CPU, independent of whether clk_{Tn} is present or not. A CPU write overrides (has priority over) all counter clear or count operations.

The counting sequence is determined by the setting of the *Waveform Generation mode* bits (WGMn3:0) located in the *Timer/Counter Control Registers A and B* (TCCRnA and TCCRnB). There are close connections between how the counter behaves (counts) and how waveforms

are generated on the output compare outputs OCnx. For more details about advanced counting sequences and waveform generation, see “Modes of Operation” on page 123.

The *Timer/Counter Overflow* (TOVn) flag is set according to the mode of operation selected by the WGMn3:0 bits. TOVn can be used for generating a CPU interrupt.

Input Capture Unit

The Timer/Counter incorporates an Input Capture unit that can capture external events and give them a time-stamp indicating time of occurrence. The external signal indicating an event, or multiple events, can be applied via the ICPn pin or alternatively, for the Timer/Counter1 only, via the Analog Comparator unit. The time-stamps can then be used to calculate frequency, duty-cycle, and other features of the signal applied. Alternatively the time-stamps can be used for creating a log of the events.

The Input Capture unit is illustrated by the block diagram shown in Figure 48. The elements of the block diagram that are not directly a part of the Input Capture unit are gray shaded. The small “n” in register and bit names indicates the Timer/Counter number.

Figure 48. Input Capture Unit Block Diagram



Note: The Analog Comparator Output (ACO) can only trigger the Timer/Counter1 ICP – not Timer/Counter3.

When a change of the logic level (an event) occurs on the *Input Capture Pin* (ICPn), alternatively on the *analog Comparator output* (ACO), and this change confirms to the setting of the edge detector, a capture will be triggered. When a capture is triggered, the 16-bit value of the counter (TCNTn) is written to the *Input Capture Register* (ICRn). The *Input Capture Flag* (ICFn) is set at the same system clock as the TCNTn value is copied into ICRn Register. If enabled (TICIE_n = 1), the Input Capture flag generates an Input Capture interrupt. The ICFn flag is automatically cleared when the interrupt is executed. Alternatively the ICFn flag can be cleared by software by writing a logical one to its I/O bit location.

Reading the 16-bit value in the *Input Capture Register* (ICRn) is done by first reading the low byte (ICRnL) and then the high byte (ICRnH). When the low byte is read the high byte is copied

into the high byte Temporary Register (TEMP). When the CPU reads the ICRnH I/O location it will access the TEMP Register.

The ICRn Register can only be written when using a Waveform Generation mode that utilizes the ICRn Register for defining the counter's TOP value. In these cases the *Waveform Generation mode* (WGMn3:0) bits must be set before the TOP value can be written to the ICRn Register. When writing the ICRn Register the high byte must be written to the ICRnH I/O location before the low byte is written to ICRnL.

For more information on how to access the 16-bit registers refer to [“Accessing 16-bit Registers” on page 114](#).

Input Capture Pin Source

The main trigger source for the Input Capture unit is the *Input Capture Pin* (ICPn). Timer/Counter1 can alternatively use the analog comparator output as trigger source for the Input Capture unit. The Analog Comparator is selected as trigger source by setting the *analog Comparator Input Capture* (ACIC) bit in the *Analog Comparator Control and Status Register* (ACSR). Be aware that changing trigger source can trigger a capture. The Input Capture flag must therefore be cleared after the change.

Both the *Input Capture Pin* (ICPn) and the *Analog Comparator output* (ACO) inputs are sampled using the same technique as for the Tn pin ([Figure 59 on page 143](#)). The edge detector is also identical. However, when the noise canceler is enabled, additional logic is inserted before the edge detector, which increases the delay by four system clock cycles. Note that the input of the noise canceler and edge detector is always enabled unless the Timer/Counter is set in a Waveform Generation mode that uses ICRn to define TOP.

An Input Capture can be triggered by software by controlling the port of the ICPn pin.

Noise Canceler

The noise canceler improves noise immunity by using a simple digital filtering scheme. The noise canceler input is monitored over four samples, and all four must be equal for changing the output that in turn is used by the edge detector.

The noise canceler is enabled by setting the *Input Capture Noise Canceler* (ICNcN) bit in *Timer/Counter Control Register B* (TCCRnB). When enabled the noise canceler introduces additional four system clock cycles of delay from a change applied to the input, to the update of the ICRn Register. The noise canceler uses the system clock and is therefore not affected by the prescaler.

Using the Input Capture Unit

The main challenge when using the Input Capture unit is to assign enough processor capacity for handling the incoming events. The time between two events is critical. If the processor has not read the captured value in the ICRn Register before the next event occurs, the ICRn will be overwritten with a new value. In this case the result of the capture will be incorrect.

When using the Input Capture interrupt, the ICRn Register should be read as early in the interrupt handler routine as possible. Even though the Input Capture interrupt has relatively high priority, the maximum interrupt response time is dependent on the maximum number of clock cycles it takes to handle any of the other interrupt requests.

Using the Input Capture unit in any mode of operation when the TOP value (resolution) is actively changed during operation, is not recommended.

Measurement of an external signal's duty cycle requires that the trigger edge is changed after each capture. Changing the edge sensing must be done as early as possible after the ICRn Register has been read. After a change of the edge, the Input Capture flag (ICFn) must be cleared by software (writing a logical one to the I/O bit location). For measuring frequency only, the clearing of the ICFn flag is not required (if an interrupt handler is used).

Output Compare Units

The 16-bit comparator continuously compares TCNTn with the *Output Compare Register* (OCRnx). If TCNT equals OCRnx the comparator signals a match. A match will set the *Output Compare Flag* (OCFnx) at the next timer clock cycle. If enabled (OCIE_n = 1), the output compare flag generates an output compare interrupt. The OCFnx flag is automatically cleared when the interrupt is executed. Alternatively the OCFnx flag can be cleared by software by writing a logical one to its I/O bit location. The Waveform Generator uses the match signal to generate an output according to operating mode set by the *Waveform Generation mode* (WGM_{n3:0}) bits and *Compare Output mode* (COM_{n1:0}) bits. The TOP and BOTTOM signals are used by the waveform generator for handling the special cases of the extreme values in some modes of operation (See “Modes of Operation” on page 123.)

A special feature of output compare unit A allows it to define the Timer/Counter TOP value (i.e., counter resolution). In addition to the counter resolution, the TOP value defines the period time for waveforms generated by the waveform generator.

Figure 49 shows a block diagram of the output compare unit. The small “n” in the register and bit names indicates the device number (n = n for Timer/Counter n), and the “x” indicates output compare unit (A/B/C). The elements of the block diagram that are not directly a part of the output compare unit are gray shaded.

Figure 49. Output Compare Unit, Block Diagram



The OCRnx Register is double buffered when using any of the twelve *Pulse Width Modulation* (PWM) modes. For the normal and *Clear Timer on Compare* (CTC) modes of operation, the double buffering is disabled. The double buffering synchronizes the update of the OCRnx Compare Register to either TOP or BOTTOM of the counting sequence. The synchronization prevents the occurrence of odd-length, non-symmetrical PWM pulses, thereby making the output glitch-free.

The OCRnx Register access may seem complex, but this is not case. When the double buffering is enabled, the CPU has access to the OCRnx buffer register, and if double buffering is disabled the CPU will access the OCRnx directly. The content of the OCR1x (buffer or compare) register is only changed by a write operation (the Timer/Counter does not update this register automatically as the TCNTn- and ICRn Register). Therefore OCRnx is not read via the high byte Temporary Register (TEMP). However, it is a good practice to read the low byte first as when accessing other 16-bit registers. Writing the OCRnx registers must be done via the TEMP Register since the compare of all 16 bits is done continuously. The high byte (OCRnxH) has to be written first. When the high byte I/O location is written by the CPU, the TEMP Register will be updated by the value written. Then when the low byte (OCRnxL) is written to the lower 8 bits, the high byte will be copied into the upper 8 bits of either the OCRnx buffer or OCRnx Compare Register in the same system clock cycle.

For more information of how to access the 16-bit registers refer to [“Accessing 16-bit Registers” on page 114](#).

Force Output Compare

In non-PWM Waveform Generation modes, the match output of the comparator can be forced by writing a one to the *Force Output Compare* (FOCnx) bit. Forcing compare match will not set the OCFnx flag or reload/clear the timer, but the OCnx pin will be updated as if a real compare match had occurred (the COMnx1:0 bits settings define whether the OCnx pin is set, cleared or toggled).

Compare Match Blocking by TCNTn Write

All CPU writes to the TCNTn Register will block any compare match that occurs in the next timer clock cycle, even when the timer is stopped. This feature allows OCRnx to be initialized to the same value as TCNTn without triggering an interrupt when the Timer/Counter clock is enabled.

Using the Output Compare Unit

Since writing TCNTn in any mode of operation will block all compare matches for one timer clock cycle, there are risks involved when changing TCNTn when using any of the output compare channels, independent of whether the Timer/Counter is running or not. If the value written to TCNTn equals the OCRnx value, the compare match will be missed, resulting in incorrect waveform generation. Do not write the TCNTn equal to TOP in PWM modes with variable TOP values. The compare match for the TOP will be ignored and the counter will continue to 0xFFFF. Similarly, do not write the TCNTn value equal to BOTTOM when the counter is downcounting.

The setup of the OCnx should be performed before setting the Data Direction Register for the port pin to output. The easiest way of setting the OCnx value is to use the force output compare (FOCnx) strobe bits in normal mode. The OCnx Register keeps its value even when changing between waveform generation modes.

Be aware that the COMnx1:0 bits are not double buffered together with the compare value. Changing the COMnx1:0 bits will take effect immediately.

Compare Match Output Unit

The *Compare Output mode* (COMnx1:0) bits have two functions. The waveform generator uses the COMnx1:0 bits for defining the output compare (OCnx) state at the next compare match. Secondly the COMnx1:0 bits control the OCnx pin output source. [Figure 50](#) shows a simplified schematic of the logic affected by the COMnx1:0 bit setting. The I/O registers, I/O bits, and I/O pins in the figure are shown in bold. Only the parts of the general I/O port control registers (DDR and PORT) that are affected by the COMnx1:0 bits are shown. When referring to the OCnx state, the reference is for the internal OCnx Register, not the OCnx pin. If a system Reset occur, the OCnx Register is reset to “0”.

Figure 50. Compare Match Output Unit, Schematic

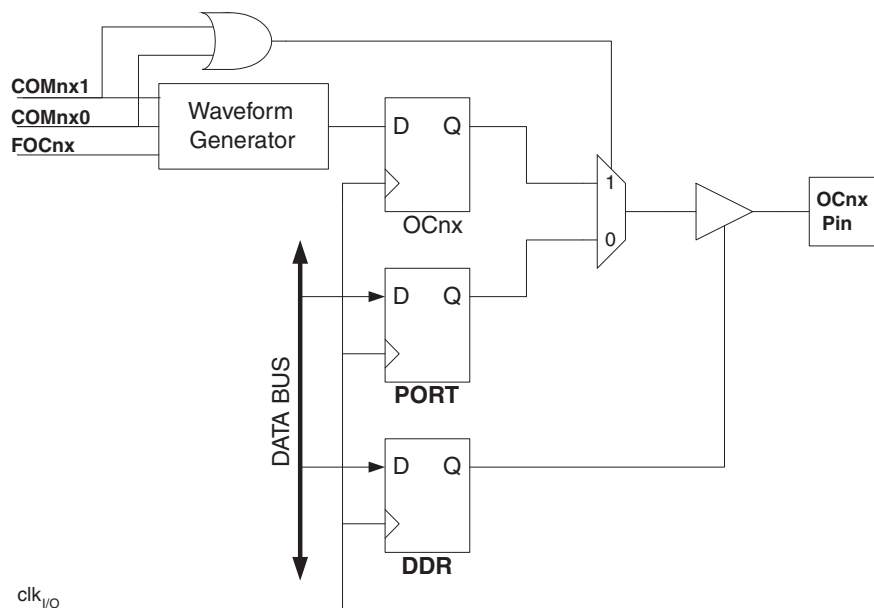

The general I/O port function is overridden by the output compare (OCnx) from the Waveform Generator if either of the COMnx1:0 bits are set. However, the OCnx pin direction (input or output) is still controlled by the *Data Direction Register* (DDR) for the port pin. The data direction register bit for the OCnx pin (DDR_OCnx) must be set as output before the OCnx value is visible on the pin. The port override function is generally independent of the waveform generation mode, but there are some exceptions. Refer to [Table 58](#), [Table 59](#) and [Table 60](#) for details.

The design of the output compare pin logic allows initialization of the OCnx state before the output is enabled. Note that some COMnx1:0 bit settings are reserved for certain modes of operation. See [“16-bit Timer/Counter Register Description”](#) on page 132.

The COMnx1:0 bits have no effect on the Input Capture unit.

Compare Output Mode and Waveform Generation

The waveform generator uses the COMnx1:0 bits differently in normal, CTC, and PWM modes. For all modes, setting the COMnx1:0 = 0 tells the waveform generator that no action on the OCnx Register is to be performed on the next compare match. For compare output actions in the non-PWM modes refer to [Table 58](#) on page 132. For fast PWM mode refer to [Table 59](#) on page 133, and for phase correct and phase and frequency correct PWM refer to [Table 60](#) on page 133.

A change of the COMnx1:0 bits state will have effect at the first compare match after the bits are written. For non-PWM modes, the action can be forced to have immediate effect by using the FOCnx strobe bits.

Modes of Operation

The mode of operation, i.e., the behavior of the Timer/Counter and the output compare pins, is defined by the combination of the *Waveform Generation mode* (WGMn3:0) and *Compare Output mode* (COMnx1:0) bits. The Compare Output mode bits do not affect the counting sequence, while the waveform generation mode bits do. The COMnx1:0 bits control whether the PWM output generated should be inverted or not (inverted or non-inverted PWM). For non-PWM modes the COMnx1:0 bits control whether the output should be set, cleared or toggle at a compare match (See “Compare Match Output Unit” on page 122.)

For detailed timing information refer to “Timer/Counter Timing Diagrams” on page 130.

Normal Mode

The simplest mode of operation is the *normal* mode (WGMn3:0 = 0). In this mode the counting direction is always up (incrementing), and no counter clear is performed. The counter simply overruns when it passes its maximum 16-bit value (MAX = 0xFFFF) and then restarts from the BOTTOM (0x0000). In normal operation the *Timer/Counter Overflow Flag* (TOVn) will be set in the same timer clock cycle as the TCNTn becomes zero. The TOVn flag in this case behaves like a 17th bit, except that it is only set, not cleared. However, combined with the timer overflow interrupt that automatically clears the TOVn flag, the timer resolution can be increased by software. There are no special cases to consider in the normal mode, a new counter value can be written anytime.

The Input Capture unit is easy to use in normal mode. However, observe that the maximum interval between the external events must not exceed the resolution of the counter. If the interval between events are too long, the timer overflow interrupt or the prescaler must be used to extend the resolution for the capture unit.

The output compare units can be used to generate interrupts at some given time. Using the output compare to generate waveforms in normal mode is not recommended, since this will occupy too much of the CPU time.

Clear Timer on Compare Match (CTC) Mode

In *Clear Timer on Compare* or CTC mode (WGMn3:0 = 4 or 12), the OCRnA or ICRn Register are used to manipulate the counter resolution. In CTC mode the counter is cleared to zero when the counter value (TCNTn) matches either the OCRnA (WGMn3:0 = 4) or the ICRn (WGMn3:0 = 12). The OCRnA or ICRn define the top value for the counter, hence also its resolution. This mode allows greater control of the compare match output frequency. It also simplifies the operation of counting external events.

The timing diagram for the CTC mode is shown in Figure 51. The counter value (TCNTn) increases until a compare match occurs with either OCRnA or ICRn, and then counter (TCNTn) is cleared.

Figure 51. CTC Mode, Timing Diagram



An interrupt can be generated at each time the counter value reaches the TOP value by either using the OCFnA or ICFn flag according to the register used to define the TOP value. If the interrupt is enabled, the interrupt handler routine can be used for updating the TOP value. However, changing the TOP to a value close to BOTTOM when the counter is running with none or a low prescaler value must be done with care since the CTC mode does not have the double buffering feature. If the new value written to OCRnA or ICRn is lower than the current value of TCNTn, the counter will miss the compare match. The counter will then have to count to its maximum value (0xFFFF) and wrap around starting at 0x0000 before the compare match can occur. In many cases this feature is not desirable. An alternative will then be to use the fast PWM mode using OCRnA for defining TOP (WGMn3:0 = 15) since the OCRnA then will be double buffered.

For generating a waveform output in CTC mode, the OCnA output can be set to toggle its logical level on each compare match by setting the compare output mode bits to toggle mode (COMnA1:0 = 1). The OCnA value will not be visible on the port pin unless the data direction for the pin is set to output (DDR_OCnA = 1). The waveform generated will have a maximum frequency of $f_{OCnA} = f_{clk_I/O}/2$ when OCRnA is set to zero (0x0000). The waveform frequency is defined by the following equation:

$$f_{OCnA} = \frac{f_{clk_I/O}}{2 \cdot N \cdot (1 + OCRnA)}$$

The N variable represents the prescaler factor (1, 8, 64, 256, or 1024).

As for the normal mode of operation, the TOVn flag is set in the same timer clock cycle that the counter counts from MAX to 0x0000.

Fast PWM Mode

The *fast Pulse Width Modulation* or fast PWM mode (WGMn3:0 = 5,6,7,14, or 15) provides a high frequency PWM waveform generation option. The fast PWM differs from the other PWM options by its single-slope operation. The counter counts from BOTTOM to TOP then restarts from BOTTOM. In non-inverting Compare Output mode, the output compare (OCnx) is cleared on the compare match between TCNTn and OCRnx, and set at BOTTOM. In inverting compare output mode output is set on compare match and cleared at BOTTOM. Due to the single-slope operation, the operating frequency of the fast PWM mode can be twice as high as the phase correct and phase and frequency correct PWM modes that use dual-slope operation. This high frequency makes the fast PWM mode well suited for power regulation, rectification, and DAC applications. High frequency allows physically small sized external components (coils, capacitors), hence reduces total system cost.

The PWM resolution for fast PWM can be fixed to 8-bit, 9-bit, or 10-bit, or defined by either ICRn or OCRnA. The minimum resolution allowed is 2-bit (ICRn or OCRnA set to 0x0003), and the maximum resolution is 16-bit (ICRn or OCRnA set to MAX). The PWM resolution in bits can be calculated by using the following equation:

$$R_{FPWM} = \frac{\log(TOP + 1)}{\log(2)}$$

In fast PWM mode the counter is incremented until the counter value matches either one of the fixed values 0x00FF, 0x01FF, or 0x03FF (WGMn3:0 = 5, 6, or 7), the value in ICRn (WGMn3:0 = 14), or the value in OCRnA (WGMn3:0 = 15). The counter is then cleared at the following timer clock cycle. The timing diagram for the fast PWM mode is shown in [Figure 52](#). The figure shows fast PWM mode when OCRnA or ICRn is used to define TOP. The TCNTn value is in the timing diagram shown as a histogram for illustrating the single-slope operation. The diagram includes non-inverted and inverted PWM outputs. The small horizontal line marks on the TCNTn slopes represent compare matches between OCRnx and TCNTn. The OCnx interrupt flag will be set when a compare match occurs.

Figure 52. Fast PWM Mode, Timing Diagram

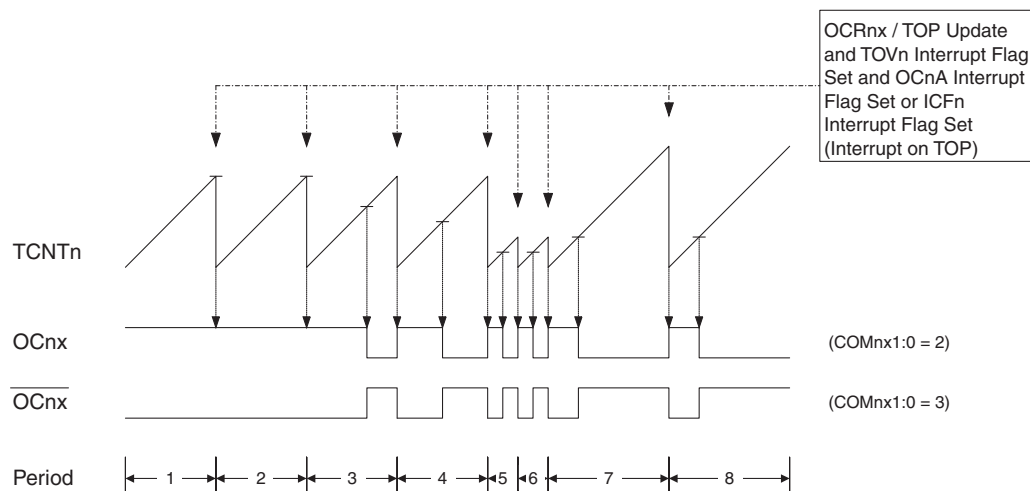

The Timer/Counter Overflow Flag (TOVn) is set each time the counter reaches TOP. In addition the OCnA or ICFn flag is set at the same timer clock cycle as TOVn is set when either OCRnA or ICRn is used for defining the TOP value. If one of the interrupts are enabled, the interrupt handler routine can be used for updating the TOP and compare values.

When changing the TOP value the program must ensure that the new TOP value is higher or equal to the value of all of the compare registers. If the TOP value is lower than any of the compare registers, a compare match will never occur between the TCNTn and the OCRnx. Note that when using fixed TOP values the unused bits are masked to zero when any of the OCRnx Registers are written.

The procedure for updating ICRn differs from updating OCRnA when used for defining the TOP value. The ICRn Register is not double buffered. This means that if ICRn is changed to a low value when the counter is running with none or a low prescaler value, there is a risk that the new ICRn value written is lower than the current value of TCNTn. The result will then be that the counter will miss the compare match at the TOP value. The counter will then have to count to the MAX value (0xFFFF) and wrap around starting at 0x0000 before the compare match can occur. The OCRnA Register however, is double buffered. This feature allows the OCRnA I/O location to be written anytime. When the OCRnA I/O location is written the value written will be put into the OCRnA buffer Register. The OCRnA Compare Register will then be updated with the value in the buffer register at the next timer clock cycle the TCNTn matches TOP. The update is done at the same timer clock cycle as the TCNTn is cleared and the TOVn flag is set.

Using the ICRn Register for defining TOP works well when using fixed TOP values. By using ICRn, the OCRnA Register is free to be used for generating a PWM output on OCnA. However, if the base PWM frequency is actively changed (by changing the TOP value), using the OCRnA as TOP is clearly a better choice due to its double buffer feature.

In fast PWM mode, the compare units allow generation of PWM waveforms on the OCnx pins. Setting the COMnx1:0 bits to 2 will produce a non-inverted PWM and an inverted PWM output can be generated by setting the COMnx1:0 to 3 (See [Table 59 on page 133](#)). The actual OCnx value will only be visible on the port pin if the data direction for the port pin is set as output (DDR_OCnx). The PWM waveform is generated by setting (or clearing) the OCnx Register at the compare match between OCRnx and TCNTn, and clearing (or setting) the OCnx Register at the timer clock cycle the counter is cleared (changes from TOP to BOTTOM).

The PWM frequency for the output can be calculated by the following equation:

$$f_{OCnXPWM} = \frac{f_{clk_I/O}}{N \cdot (1 + TOP)}$$

The N variable represents the prescaler divider (1, 8, 64, 256, or 1024).

The extreme values for the OCRnx Register represents special cases when generating a PWM waveform output in the fast PWM mode. If the OCRnx is set equal to BOTTOM (0x0000) the output will be a narrow spike for each TOP+1 timer clock cycle. Setting the OCRnx equal to TOP will result in a constant high or low output (depending on the polarity of the output set by the COMnx1:0 bits.)

A frequency (with 50% duty cycle) waveform output in fast PWM mode can be achieved by setting OCnA to toggle its logical level on each compare match (COMnA1:0 = 1). This applies only if OCRnA is used to define the TOP value (WGMn3:0 = 15). The waveform generated will have a maximum frequency of $f_{OCnA} = f_{clk_I/O}/2$ when OCRnA is set to zero (0x0000). This feature is similar to the OCnA toggle in CTC mode, except the double buffer feature of the output compare unit is enabled in the fast PWM mode.

Phase Correct PWM Mode

The *phase correct Pulse Width Modulation* or phase correct PWM mode (WGMn3:0 = 1, 2, 3, 10, or 11) provides a high resolution phase correct PWM waveform generation option. The phase correct PWM mode is, like the phase and frequency correct PWM mode, based on a dual-slope operation. The counter counts repeatedly from BOTTOM (0x0000) to TOP and then from TOP to BOTTOM. In non-inverting compare output mode, the output compare (OCnx) is cleared on the compare match between TCNTn and OCRnx while counting up, and set on the compare match while downcounting. In inverting Output Compare mode, the operation is inverted. The dual-slope operation has lower maximum operation frequency than single slope operation. However, due to the symmetric feature of the dual-slope PWM modes, these modes are preferred for motor control applications.

The PWM resolution for the phase correct PWM mode can be fixed to 8-bit, 9-bit, or 10-bit, or defined by either ICRn or OCRnA. The minimum resolution allowed is 2 bit (ICRn or OCRnA set to 0x0003), and the maximum resolution is 16 bit (ICRn or OCRnA set to MAX). The PWM resolution in bits can be calculated by using the following equation:

$$R_{PCPWM} = \frac{\log(TOP + 1)}{\log(2)}$$

In phase correct PWM mode the counter is incremented until the counter value matches either one of the fixed values 0x00FF, 0x01FF, or 0x03FF (WGMn3:0 = 1, 2, or 3), the value in ICRn (WGMn3:0 = 10), or the value in OCRnA (WGMn3:0 = 11). The counter has then reached the TOP and changes the count direction. The TCNTn value will be equal to TOP for one timer clock cycle. The timing diagram for the phase correct PWM mode is shown on [Figure 53](#). The figure shows phase correct PWM mode when OCRnA or ICRn is used to define TOP. The TCNTn value is in the timing diagram shown as a histogram for illustrating the dual-slope operation. The diagram includes non-inverted and inverted PWM outputs. The small horizontal line marks on the TCNTn slopes represent compare matches between OCRnx and TCNTn. The OCnx interrupt flag will be set when a compare match occurs.

Figure 53. Phase Correct PWM Mode, Timing Diagram



The Timer/Counter Overflow Flag (TOVn) is set each time the counter reaches BOTTOM. When either OCRnA or ICRn is used for defining the TOP value, the OCnA or ICFn flag is set accordingly at the same timer clock cycle as the OCRnX Registers are updated with the double buffer value (at TOP). The interrupt flags can be used to generate an interrupt each time the counter reaches the TOP or BOTTOM value.

When changing the TOP value the program must ensure that the new TOP value is higher or equal to the value of all of the compare registers. If the TOP value is lower than any of the compare registers, a compare match will never occur between the TCNTn and the OCRnX. Note that when using fixed TOP values, the unused bits are masked to zero when any of the OCRnX Registers are written. As the third period shown in [Figure 53](#) illustrates, changing the TOP actively while the Timer/Counter is running in the phase correct mode can result in an unsymmetrical output. The reason for this can be found in the time of update of the OCRnX Register. Since the OCRnX update occurs at TOP, the PWM period starts and ends at TOP. This implies that the length of the falling slope is determined by the previous TOP value, while the length of the rising slope is determined by the new TOP value. When these two values differ the two slopes of the period will differ in length. The difference in length gives the unsymmetrical result on the output.

It is recommended to use the phase and frequency correct mode instead of the phase correct mode when changing the TOP value while the Timer/Counter is running. When using a static TOP value there are practically no differences between the two modes of operation.

In phase correct PWM mode, the compare units allow generation of PWM waveforms on the OCnx pins. Setting the COMnx1:0 bits to 2 will produce a non-inverted PWM and an inverted PWM output can be generated by setting the COMnx1:0 to 3 (See [Table 60 on page 133](#)). The actual OCnx value will only be visible on the port pin if the data direction for the port pin is set as output (DDR_OCnx). The PWM waveform is generated by setting (or clearing) the OCnx Register at the compare match between OCRnX and TCNTn when the counter increments, and clearing (or setting) the OCnx Register at compare match between OCRnX and TCNTn when

the counter decrements. The PWM frequency for the output when using phase correct PWM can be calculated by the following equation:

$$f_{OCnxPCPWM} = \frac{f_{clk_I/O}}{2 \cdot N \cdot TOP}$$

The N variable represents the prescaler divider (1, 8, 64, 256, or 1024).

The extreme values for the OCRnx Register represents special cases when generating a PWM waveform output in the phase correct PWM mode. If the OCRnx is set equal to BOTTOM the output will be continuously low and if set equal to TOP the output will be continuously high for non-inverted PWM mode. For inverted PWM the output will have the opposite logic values.

If OCnA is used to define the TOP value (WGMn3:0 = 11) and COMnA1:0 = 1, the OCnA Output will toggle with a 50% duty cycle.

Phase and Frequency Correct PWM Mode

The *phase and frequency correct Pulse Width Modulation*, or phase and frequency correct PWM mode (WGMn3:0 = 8 or 9) provides a high resolution phase and frequency correct PWM waveform generation option. The phase and frequency correct PWM mode is, like the phase correct PWM mode, based on a dual-slope operation. The counter counts repeatedly from BOTTOM (0x0000) to TOP and then from TOP to BOTTOM. In non-inverting Compare Output mode, the output compare (OCnx) is cleared on the compare match between TCNTn and OCRnx while counting up, and set on the compare match while downcounting. In inverting Compare Output mode, the operation is inverted. The dual-slope operation gives a lower maximum operation frequency compared to the single-slope operation. However, due to the symmetric feature of the dual-slope PWM modes, these modes are preferred for motor control applications.

The main difference between the phase correct, and the phase and frequency correct PWM mode is the time the OCRnx Register is updated by the OCRnx buffer Register, (see [Figure 53](#) and [Figure 54](#)).

The PWM resolution for the phase and frequency correct PWM mode can be defined by either ICRn or OCRnA. The minimum resolution allowed is 2-bit (ICRn or OCRnA set to 0x0003), and the maximum resolution is 16-bit (ICRn or OCRnA set to MAX). The PWM resolution in bits can be calculated using the following equation:

$$R_{PFCPWM} = \frac{\log(TOP + 1)}{\log(2)}$$

In phase and frequency correct PWM mode the counter is incremented until the counter value matches either the value in ICRn (WGMn3:0 = 8), or the value in OCRnA (WGMn3:0 = 9). The counter has then reached the TOP and changes the count direction. The TCNTn value will be equal to TOP for one timer clock cycle. The timing diagram for the phase correct and frequency correct PWM mode is shown on [Figure 54](#). The figure shows phase and frequency correct PWM mode when OCRnA or ICRn is used to define TOP. The TCNTn value is in the timing diagram shown as a histogram for illustrating the dual-slope operation. The diagram includes non-inverted and inverted PWM outputs. The small horizontal line marks on the TCNTn slopes represent compare matches between OCRnx and TCNTn. The OCnx interrupt flag will be set when a compare match occurs.

Figure 54. Phase and Frequency Correct PWM Mode, Timing Diagram



The Timer/Counter Overflow Flag (TOVn) is set at the same timer clock cycle as the OCRnx Registers are updated with the double buffer value (at BOTTOM). When either OCRnA or ICRn is used for defining the TOP value, the OCnA or ICFn flag set when TCNTn has reached TOP. The interrupt flags can then be used to generate an interrupt each time the counter reaches the TOP or BOTTOM value.

When changing the TOP value the program must ensure that the new TOP value is higher or equal to the value of all of the compare registers. If the TOP value is lower than any of the compare registers, a compare match will never occur between the TCNTn and the OCRnx.

As Figure 54 shows the output generated is, in contrast to the phase correct mode, symmetrical in all periods. Since the OCRnx Registers are updated at BOTTOM, the length of the rising and the falling slopes will always be equal. This gives symmetrical output pulses and is therefore frequency correct.

Using the ICRn Register for defining TOP works well when using fixed TOP values. By using ICRn, the OCRnA Register is free to be used for generating a PWM output on OCnA. However, if the base PWM frequency is actively changed by changing the TOP value, using the OCRnA as TOP is clearly a better choice due to its double buffer feature.

In phase and frequency correct PWM mode, the compare units allow generation of PWM waveforms on the OCnx pins. Setting the COMnx1:0 bits to 2 will produce a non-inverted PWM and an inverted PWM output can be generated by setting the COMnx1:0 to 3 (See Table 60 on page 133). The actual OCnx value will only be visible on the port pin if the data direction for the port pin is set as output (DDR_OCnx). The PWM waveform is generated by setting (or clearing) the OCnx Register at the compare match between OCRnx and TCNTn when the counter increments, and clearing (or setting) the OCnx Register at compare match between OCRnx and TCNTn when the counter decrements. The PWM frequency for the output when using phase and frequency correct PWM can be calculated by the following equation:

$$f_{OCnxPFCPWM} = \frac{f_{clk_I/O}}{2 \cdot N \cdot TOP}$$

The N variable represents the prescaler divider (1, 8, 64, 256, or 1024).

The extreme values for the OCRnx Register represent special cases when generating a PWM waveform output in the phase correct PWM mode. If the OCRnx is set equal to BOTTOM the output will be continuously low and if set equal to TOP the output will be set to high for non-inverted PWM mode. For inverted PWM the output will have the opposite logic values.

If OCRnA is used to define the TOP value ($WGMn3:0 = 9$) and $COMnA1:0 = 1$, the OCnA Output will toggle with a 50% duty cycle.

Timer/Counter Timing Diagrams

The Timer/Counter is a synchronous design and the timer clock (clk_{Tn}) is therefore shown as a clock enable signal in the following figures. The figures include information on when interrupt flags are set, and when the OCRnx Register is updated with the OCRnx buffer value (only for modes utilizing double buffering). [Figure 55](#) shows a timing diagram for the setting of OCFnx.

Figure 55. Timer/Counter Timing Diagram, Setting of OCFnx, no Prescaling



[Figure 56](#) shows the same timing data, but with the prescaler enabled.

Figure 56. Timer/Counter Timing Diagram, Setting of OCFnx, with Prescaler ($f_{clk_I/O}/8$)



Figure 57 shows the count sequence close to TOP in various modes. When using phase and frequency correct PWM mode the OCRnx Register is updated at BOTTOM. The timing diagrams will be the same, but TOP should be replaced by BOTTOM, TOP-1 by BOTTOM+1 and so on. The same renaming applies for modes that set the TOVn flag at BOTTOM.

Figure 57. Timer/Counter Timing Diagram, no Prescaling



Figure 58 shows the same timing data, but with the prescaler enabled.

Figure 58. Timer/Counter Timing Diagram, with Prescaler ($f_{clk_{I/O}}/8$)



16-bit Timer/Counter Register Description

Timer/Counter1 Control Register A – TCCR1A

| | | | | | | | | | |
|---------------|--------|--------|--------|--------|--------|--------|-------|-------|--------|
| Bit | 7 | 6 | 5 | 4 | 3 | 2 | 1 | 0 | |
| | COM1A1 | COM1A0 | COM1B1 | COM1B0 | COM1C1 | COM1C0 | WGM11 | WGM10 | TCCR1A |
| Read/Write | R/W | R/W | R/W | R/W | R/W | R/W | R/W | R/W | |
| Initial Value | 0 | 0 | 0 | 0 | 0 | 0 | 0 | 0 | |

Timer/Counter3 Control Register A – TCCR3A

| | | | | | | | | | |
|---------------|--------|--------|--------|--------|--------|--------|-------|-------|--------|
| Bit | 7 | 6 | 5 | 4 | 3 | 2 | 1 | 0 | |
| | COM3A1 | COM3A0 | COM3B1 | COM3B0 | COM3C1 | COM3C0 | WGM31 | WGM30 | TCCR3A |
| Read/Write | R/W | R/W | R/W | R/W | R/W | R/W | R/W | R/W | |
| Initial Value | 0 | 0 | 0 | 0 | 0 | 0 | 0 | 0 | |

- **Bit 7:6 – COMnA1:0: Compare Output Mode for Channel A**
- **Bit 5:4 – COMnB1:0: Compare Output Mode for Channel B**
- **Bit 3:2 – COMnC1:0: Compare Output Mode for Channel C**

The COMnA1:0, COMnB1:0, and COMnC1:0 control the output compare pins (OCnA, OCnB, and OCnC respectively) behavior. If one or both of the COMnA1:0 bits are written to one, the OCnA output overrides the normal port functionality of the I/O pin it is connected to. If one or both of the COMnB1:0 bits are written to one, the OCnB output overrides the normal port functionality of the I/O pin it is connected to. If one or both of the COMnC1:0 bits are written to one, the OCnC output overrides the normal port functionality of the I/O pin it is connected to. However, note that the *Data Direction Register* (DDR) bit corresponding to the OCnA, OCnB or OCnC pin must be set in order to enable the output driver.

When the OCnA, OCnB or OCnC is connected to the pin, the function of the COMnx1:0 bits is dependent of the WGMn3:0 bits setting. [Table 58](#) shows the COMnx1:0 bit functionality when the WGMn3:0 bits are set to a normal or a CTC mode (non-PWM).

Table 58. Compare Output Mode, non-PWM

| COMnA1/COMnB1/ COMnC1 | COMnA0/COMnB0/ COMnC0 | Description |
|--------------------------|--------------------------|--|
| 0 | 0 | Normal port operation, OCnA/OCnB/OCnC disconnected. |
| 0 | 1 | Toggle OCnA/OCnB/OCnC on compare match. |
| 1 | 0 | Clear OCnA/OCnB/OCnC on compare match (set output to low level). |
| 1 | 1 | Set OCnA/OCnB/OCnC on compare match (set output to high level). |

Table 59 shows the COMnx1:0 bit functionality when the WGMn3:0 bits are set to the fast PWM mode

Table 59. Compare Output Mode, Fast PWM

| COMnA1/COMnB1/ COMnC1 | COMnA0/COMnB0/ COMnC0 | Description |
|--------------------------|--------------------------|---|
| 0 | 0 | Normal port operation, OCnA/OCnB/OCnC disconnected. |
| 0 | 1 | WGMn3:0 = 15: Toggle OCnA on Compare Match, OCnB/OCnC disconnected (normal port operation). For all other WGMn settings, normal port operation, OCnA/OCnB/OCnC disconnected. |
| 1 | 0 | Clear OCnA/OCnB/OCnC on compare match, set OCnA/OCnB/OCnC at BOTTOM, (non-inverting mode) |
| 1 | 1 | Set OCnA/OCnB/OCnC on compare match, clear OCnA/OCnB/OCnC at BOTTOM, (inverting mode) |

Note: A special case occurs when OCRnA/OCRnB/OCRnC equals TOP and COMnA1/COMnB1/COMnC1 is set. In this case the compare match is ignored, but the set or clear is done at BOTTOM. See “Fast PWM Mode” on page 124. for more details.

Table 59 shows the COMnx1:0 bit functionality when the WGMn3:0 bits are set to the phase correct and frequency correct PWM mode.

Table 60. Compare Output Mode, Phase Correct and Phase and Frequency Correct PWM

| COMnA1/COMnB1/ COMnC1 | COMnA0/COMnB0/ COMnC0 | Description |
|--------------------------|--------------------------|--|
| 0 | 0 | Normal port operation, OCnA/OCnB/OCnC disconnected. |
| 0 | 1 | WGMn3:0 = 9 or 11: Toggle OCnA on Compare Match, OCnB/OCnC disconnected (normal port operation). For all other WGMn settings, normal port operation, OCnA/OCnB/OCnC disconnected. |
| 1 | 0 | Clear OCnA/OCnB/OCnC on compare match when up-counting. Set OCnA/OCnB/OCnC on compare match when downcounting. |
| 1 | 1 | Set OCnA/OCnB/OCnC on compare match when up-counting. Clear OCnA/OCnB/OCnC on compare match when downcounting. |

Note: A special case occurs when OCRnA/OCRnB/OCRnC equals TOP and COMnA1/COMnB1//COMnC1 is set. See “Phase Correct PWM Mode” on page 126. for more details.

• **Bit 1:0 – WGMn1:0: Waveform Generation Mode**

Combined with the WGMn3:2 bits found in the TCCRnB Register, these bits control the counting sequence of the counter, the source for maximum (TOP) counter value, and what type of waveform generation to be used, see [Table 61](#). Modes of operation supported by the Timer/Counter unit are: Normal mode (counter), Clear Timer on Compare match (CTC) mode, and three types of Pulse Width Modulation (PWM) modes. (See “Modes of Operation” on page 123.)

Table 61. Waveform Generation Mode Bit Description

| Mode | WGMn3 | WGMn2 (CTCn) | WGMn1 (PWMn1) | WGMn0 (PWMn0) | Timer/Counter Mode of Operation ⁽¹⁾ | TOP | Update of OCRnx at | TOVn Flag Set on |
|------|-------|--------------|---------------|---------------|--|--------|--------------------|------------------|
| 0 | 0 | 0 | 0 | 0 | Normal | 0xFFFF | Immediate | MAX |
| 1 | 0 | 0 | 0 | 1 | PWM, Phase Correct, 8-bit | 0x00FF | TOP | BOTTOM |
| 2 | 0 | 0 | 1 | 0 | PWM, Phase Correct, 9-bit | 0x01FF | TOP | BOTTOM |
| 3 | 0 | 0 | 1 | 1 | PWM, Phase Correct, 10-bit | 0x03FF | TOP | BOTTOM |
| 4 | 0 | 1 | 0 | 0 | CTC | OCRnA | Immediate | MAX |
| 5 | 0 | 1 | 0 | 1 | Fast PWM, 8-bit | 0x00FF | BOTTOM | TOP |
| 6 | 0 | 1 | 1 | 0 | Fast PWM, 9-bit | 0x01FF | BOTTOM | TOP |
| 7 | 0 | 1 | 1 | 1 | Fast PWM, 10-bit | 0x03FF | BOTTOM | TOP |
| 8 | 1 | 0 | 0 | 0 | PWM, Phase and Frequency Correct | ICRn | BOTTOM | BOTTOM |
| 9 | 1 | 0 | 0 | 1 | PWM, Phase and Frequency Correct | OCRnA | BOTTOM | BOTTOM |
| 10 | 1 | 0 | 1 | 0 | PWM, Phase Correct | ICRn | TOP | BOTTOM |
| 11 | 1 | 0 | 1 | 1 | PWM, Phase Correct | OCRnA | TOP | BOTTOM |
| 12 | 1 | 1 | 0 | 0 | CTC | ICRn | Immediate | MAX |
| 13 | 1 | 1 | 0 | 1 | (Reserved) | – | – | – |
| 14 | 1 | 1 | 1 | 0 | Fast PWM | ICRn | BOTTOM | TOP |
| 15 | 1 | 1 | 1 | 1 | Fast PWM | OCRnA | BOTTOM | TOP |

Note: 1. The CTCn and PWMn1:0 bit definition names are obsolete. Use the WGMn2:0 definitions. However, the functionality and location of these bits are compatible with previous versions of the timer.

Timer/Counter1 Control Register B – TCCR1B

| Bit | 7 | 6 | 5 | 4 | 3 | 2 | 1 | 0 | |
|---------------|-------|-------|---|-------|-------|------|------|------|--------|
| | ICNC1 | ICES1 | – | WGM13 | WGM12 | CS12 | CS11 | CS10 | TCCR1B |
| Read/Write | R/W | R/W | R | R/W | R/W | R/W | R/W | R/W | |
| Initial Value | 0 | 0 | 0 | 0 | 0 | 0 | 0 | 0 | |

Timer/Counter3 Control Register B – TCCR3B

| Bit | 7 | 6 | 5 | 4 | 3 | 2 | 1 | 0 | |
|---------------|-------|-------|---|-------|-------|------|------|------|--------|
| | ICNC3 | ICES3 | – | WGM33 | WGM32 | CS32 | CS31 | CS30 | TCCR3B |
| Read/Write | R/W | R/W | R | R/W | R/W | R/W | R/W | R/W | |
| Initial Value | 0 | 0 | 0 | 0 | 0 | 0 | 0 | 0 | |

- **Bit 7 – ICNCn: Input Capture Noise Canceler**

Setting this bit (to one) activates the Input Capture Noise Canceler. When the Noise Canceler is activated, the input from the Input Capture Pin (ICPn) is filtered. The filter function requires four successive equal valued samples of the ICPn pin for changing its output. The Input Capture is therefore delayed by four Oscillator cycles when the noise canceler is enabled.

- **Bit 6 – ICESn: Input Capture Edge Select**

This bit selects which edge on the Input Capture Pin (ICPn) that is used to trigger a capture event. When the ICESn bit is written to zero, a falling (negative) edge is used as trigger, and when the ICESn bit is written to one, a rising (positive) edge will trigger the capture.

When a capture is triggered according to the ICESn setting, the counter value is copied into the Input Capture Register (ICRn). The event will also set the Input Capture Flag (ICF_n), and this can be used to cause an Input Capture Interrupt, if this interrupt is enabled.

When the ICRn is used as TOP value (see description of the WGMn3:0 bits located in the TCCRnA and the TCCRnB Register), the ICPn is disconnected and consequently the Input Capture function is disabled.

- **Bit 5 – Reserved Bit**

This bit is reserved for future use. For ensuring compatibility with future devices, this bit must be written to zero when TCCRnB is written.

- **Bit 4:3 – WGMn3:2: Waveform Generation Mode**

See TCCRnA Register description.

- **Bit 2:0 – CSn2:0: Clock Select**

The three clock select bits select the clock source to be used by the Timer/Counter, see [Figure 55](#) and [Figure 56](#).

Table 62. Clock Select Bit Description

| CSn2 | CSn1 | CSn0 | Description |
|------|------|------|--|
| 0 | 0 | 0 | No clock source. (Timer/Counter stopped) |
| 0 | 0 | 1 | clk _{I/O} /1 (No prescaling) |
| 0 | 1 | 0 | clk _{I/O} /8 (From prescaler) |
| 0 | 1 | 1 | clk _{I/O} /64 (From prescaler) |
| 1 | 0 | 0 | clk _{I/O} /256 (From prescaler) |
| 1 | 0 | 1 | clk _{I/O} /1024 (From prescaler) |
| 1 | 1 | 0 | External clock source on Tn pin. Clock on falling edge |
| 1 | 1 | 1 | External clock source on Tn pin. Clock on rising edge |

If external pin modes are used for the Timer/Counter, transitions on the Tn pin will clock the counter even if the pin is configured as an output. This feature allows software control of the counting.

Timer/Counter1 Control Register C – TCCR1C

| Bit | 7 | 6 | 5 | 4 | 3 | 2 | 1 | 0 | |
|---------------|--------------|--------------|--------------|---|---|---|---|---|---------------|
| | FOC1A | FOC1B | FOC1C | – | – | – | – | – | TCCR1C |
| Read/Write | W | W | W | R | R | R | R | R | |
| Initial Value | 0 | 0 | 0 | 0 | 0 | 0 | 0 | 0 | |

Timer/Counter3 Control Register C – TCCR3C

| Bit | 7 | 6 | 5 | 4 | 3 | 2 | 1 | 0 | |
|---------------|--------------|--------------|--------------|---|---|---|---|---|---------------|
| | FOC3A | FOC3B | FOC3C | – | – | – | – | – | TCCR3C |
| Read/Write | W | W | W | R | R | R | R | R | |
| Initial Value | 0 | 0 | 0 | 0 | 0 | 0 | 0 | 0 | |

- **Bit 7 – FOCnA: Force Output Compare for Channel A**
- **Bit 6 – FOCnB: Force Output Compare for Channel B**
- **Bit 5 – FOCnC: Force Output Compare for Channel C**

The FOCnA/FOCnB/FOCnC bits are only active when the WGMn3:0 bits specifies a non-PWM mode. When writing a logical one to the FOCnA/FOCnB/FOCnC bit, an immediate compare match is forced on the waveform generation unit. The OCnA/OCnB/OCnC output is changed according to its COMnx1:0 bits setting. Note that the FOCnA/FOCnB/FOCnC bits are implemented as strobes. Therefore it is the value present in the COMnx1:0 bits that determine the effect of the forced compare.

A FOCnA/FOCnB/FOCnC strobe will not generate any interrupt nor will it clear the timer in Clear Timer on Compare Match (CTC) mode using OCRnA as TOP.

The FOCnA/FOCnB/FOCnB bits are always read as zero.

- **Bit 4:0 – Reserved Bits**

These bits are reserved for future use. For ensuring compatibility with future devices, these bits must be written to zero when TCCRnC is written.

Timer/Counter1 – TCNT1H and TCNT1L

| | | | | | | | | | |
|---------------|-------------|-----|-----|-----|-----|-----|-----|-----|------------------|
| Bit | 7 | 6 | 5 | 4 | 3 | 2 | 1 | 0 | |
| | TCNT1[15:8] | | | | | | | | TCNT1H TCNT1L |
| | TCNT1[7:0] | | | | | | | | |
| Read/Write | R/W | R/W | R/W | R/W | R/W | R/W | R/W | R/W | |
| Initial Value | 0 | 0 | 0 | 0 | 0 | 0 | 0 | 0 | |

Timer/Counter3 – TCNT3H and TCNT3L

| | | | | | | | | | |
|---------------|-------------|-----|-----|-----|-----|-----|-----|-----|------------------|
| Bit | 7 | 6 | 5 | 4 | 3 | 2 | 1 | 0 | |
| | TCNT3[15:8] | | | | | | | | TCNT3H TCNT3L |
| | TCNT3[7:0] | | | | | | | | |
| Read/Write | R/W | R/W | R/W | R/W | R/W | R/W | R/W | R/W | |
| Initial Value | 0 | 0 | 0 | 0 | 0 | 0 | 0 | 0 | |

The two *Timer/Counter* I/O locations (TCNTnH and TCNTnL, combined TCNTn) give direct access, both for read and for write operations, to the Timer/Counter unit 16-bit counter. To ensure that both the high and low bytes are read and written simultaneously when the CPU accesses these registers, the access is performed using an 8-bit temporary High Byte Register (TEMP). This Temporary Register is shared by all the other 16-bit registers. See “[Accessing 16-bit Registers](#)” on page 114.

Modifying the counter (TCNTn) while the counter is running introduces a risk of missing a compare match between TCNTn and one of the OCRnx Registers.

Writing to the TCNTn Register blocks (removes) the compare match on the following timer clock for all compare units.

Output Compare Register 1 A – OCR1AH and OCR1AL

| | | | | | | | | | |
|---------------|-------------|-----|-----|-----|-----|-----|-----|-----|------------------|
| Bit | 7 | 6 | 5 | 4 | 3 | 2 | 1 | 0 | |
| | OCR1A[15:8] | | | | | | | | OCR1AH OCR1AL |
| | OCR1A[7:0] | | | | | | | | |
| Read/Write | R/W | R/W | R/W | R/W | R/W | R/W | R/W | R/W | |
| Initial Value | 0 | 0 | 0 | 0 | 0 | 0 | 0 | 0 | |

Output Compare Register 1 B – OCR1BH and OCR1BL

| | | | | | | | | | |
|---------------|-------------|-----|-----|-----|-----|-----|-----|-----|------------------|
| Bit | 7 | 6 | 5 | 4 | 3 | 2 | 1 | 0 | |
| | OCR1B[15:8] | | | | | | | | OCR1BH OCR1BL |
| | OCR1B[7:0] | | | | | | | | |
| Read/Write | R/W | R/W | R/W | R/W | R/W | R/W | R/W | R/W | |
| Initial Value | 0 | 0 | 0 | 0 | 0 | 0 | 0 | 0 | |

Output Compare Register 1 C – OCR1CH and OCR1CL

| | | | | | | | | | |
|---------------|-------------|-----|-----|-----|-----|-----|-----|-----|------------------|
| Bit | 7 | 6 | 5 | 4 | 3 | 2 | 1 | 0 | |
| | OCR1C[15:8] | | | | | | | | OCR1CH OCR1CL |
| | OCR1C[7:0] | | | | | | | | |
| Read/Write | R/W | R/W | R/W | R/W | R/W | R/W | R/W | R/W | |
| Initial Value | 0 | 0 | 0 | 0 | 0 | 0 | 0 | 0 | |

Output Compare Register 3 A – OCR3AH and OCR3AL

| | | | | | | | | | |
|---------------|-------------|-----|-----|-----|-----|-----|-----|-----|------------------|
| Bit | 7 | 6 | 5 | 4 | 3 | 2 | 1 | 0 | |
| | OCR3A[15:8] | | | | | | | | OCR3AH OCR3AL |
| | OCR3A[7:0] | | | | | | | | |
| Read/Write | R/W | R/W | R/W | R/W | R/W | R/W | R/W | R/W | |
| Initial Value | 0 | 0 | 0 | 0 | 0 | 0 | 0 | 0 | |

Output Compare Register 3 B – OCR3BH and OCR3BL

| | | | | | | | | | |
|---------------|-------------|-----|-----|-----|-----|-----|-----|-----|------------------|
| Bit | 7 | 6 | 5 | 4 | 3 | 2 | 1 | 0 | |
| | OCR3B[15:8] | | | | | | | | OCR3BH OCR3BL |
| | OCR3B[7:0] | | | | | | | | |
| Read/Write | R/W | R/W | R/W | R/W | R/W | R/W | R/W | R/W | |
| Initial Value | 0 | 0 | 0 | 0 | 0 | 0 | 0 | 0 | |

Output Compare Register 3 C – OCR3CH and OCR3CL

| | | | | | | | | | |
|---------------|-------------|-----|-----|-----|-----|-----|-----|-----|------------------|
| Bit | 7 | 6 | 5 | 4 | 3 | 2 | 1 | 0 | |
| | OCR3C[15:8] | | | | | | | | OCR3CH OCR3CL |
| | OCR3C[7:0] | | | | | | | | |
| Read/Write | R/W | R/W | R/W | R/W | R/W | R/W | R/W | R/W | |
| Initial Value | 0 | 0 | 0 | 0 | 0 | 0 | 0 | 0 | |

The Output Compare Registers contain a 16-bit value that is continuously compared with the counter value (TCNTn). A match can be used to generate an output compare interrupt, or to generate a waveform output on the OCnx pin.

The Output Compare Registers are 16-bit in size. To ensure that both the high and low bytes are written simultaneously when the CPU writes to these registers, the access is performed using an 8-bit temporary High Byte Register (TEMP). This Temporary Register is shared by all the other 16-bit registers. See [“Accessing 16-bit Registers”](#) on page 114.

Input Capture Register 1 – ICR1H and ICR1L

| | | | | | | | | | |
|---------------|------------|-----|-----|-----|-----|-----|-----|-----|----------------|
| Bit | 7 | 6 | 5 | 4 | 3 | 2 | 1 | 0 | |
| | ICR1[15:8] | | | | | | | | ICR1H ICR1L |
| | ICR1[7:0] | | | | | | | | |
| Read/Write | R/W | R/W | R/W | R/W | R/W | R/W | R/W | R/W | |
| Initial Value | 0 | 0 | 0 | 0 | 0 | 0 | 0 | 0 | |

Input Capture Register 3 – ICR3H and ICR3L

| | | | | | | | | | |
|---------------|------------|-----|-----|-----|-----|-----|-----|-----|----------------|
| Bit | 7 | 6 | 5 | 4 | 3 | 2 | 1 | 0 | |
| | ICR3[15:8] | | | | | | | | ICR3H ICR3L |
| | ICR3[7:0] | | | | | | | | |
| Read/Write | R/W | R/W | R/W | R/W | R/W | R/W | R/W | R/W | |
| Initial Value | 0 | 0 | 0 | 0 | 0 | 0 | 0 | 0 | |

The Input Capture is updated with the counter (TCNTn) value each time an event occurs on the ICPn pin (or optionally on the Analog Comparator Output for Timer/Counter1). The Input Capture can be used for defining the counter TOP value.

The Input Capture Register is 16-bit in size. To ensure that both the high and low bytes are read simultaneously when the CPU accesses these registers, the access is performed using an 8-bit temporary High Byte Register (TEMP). This Temporary Register is shared by all the other 16-bit registers. See [“Accessing 16-bit Registers”](#) on page 114.

Timer/Counter Interrupt Mask Register – TIMSK

| | | | | | | | | | |
|---------------|-------|-------|--------|--------|--------|-------|-------|-------|-------|
| Bit | 7 | 6 | 5 | 4 | 3 | 2 | 1 | 0 | |
| | OCIE2 | TOIE2 | TICIE1 | OCIE1A | OCIE1B | TOIE1 | OCIE0 | TOIE0 | TIMSK |
| Read/Write | R/W | R/W | R/W | R/W | R/W | R/W | R/W | R/W | |
| Initial Value | 0 | 0 | 0 | 0 | 0 | 0 | 0 | 0 | |

Note: This register contains interrupt control bits for several Timer/Counters, but only Timer1 bits are described in this section. The remaining bits are described in their respective timer sections.

- **Bit 5 – TICIE1: Timer/Counter1, Input Capture Interrupt Enable**

When this bit is written to one, and the I-flag in the Status Register is set (interrupts globally enabled), the Timer/Counter1 Input Capture interrupt is enabled. The corresponding interrupt vector (See “Interrupts” on page 59.) is executed when the ICF1 flag, located in TIFR, is set.

- **Bit 4 – OCIE1A: Timer/Counter1, Output Compare A Match Interrupt Enable**

When this bit is written to one, and the I-flag in the Status Register is set (interrupts globally enabled), the Timer/Counter1 Output Compare A Match Interrupt is enabled. The corresponding interrupt vector (See “Interrupts” on page 59) is executed when the OCF1A flag, located in TIFR, is set.

- **Bit 3 – OCIE1B: Timer/Counter1, Output Compare B Match Interrupt Enable**

When this bit is written to one, and the I-flag in the Status Register is set (interrupts globally enabled), the Timer/Counter1 Output Compare B Match Interrupt is enabled. The corresponding interrupt vector (See “Interrupts” on page 59) is executed when the OCF1B flag, located in TIFR, is set.

- **Bit 2 – TOIE1: Timer/Counter1, Overflow Interrupt Enable**

When this bit is written to one, and the I-flag in the Status Register is set (interrupts globally enabled), the Timer/Counter1 overflow interrupt is enabled. The corresponding interrupt vector (See “Interrupts” on page 59) is executed when the TOV1 flag, located in TIFR, is set.

Extended Timer/Counter Interrupt Mask Register – ETIMSK

| Bit | 7 | 6 | 5 | 4 | 3 | 2 | 1 | 0 | |
|---------------|---|---|--------|--------|--------|-------|--------|--------|--------|
| | - | - | TICIE3 | OCIE3A | OCIE3B | TOIE3 | OCIE3C | OCIE1C | ETIMSK |
| Read/Write | R | R | R/W | R/W | R/W | R/W | R/W | R/W | |
| Initial Value | 0 | 0 | 0 | 0 | 0 | 0 | 0 | 0 | |

Note: This register is not available in ATmega103 compatibility mode.

- **Bit 7:6 – Reserved Bits**

These bits are reserved for future use. For ensuring compatibility with future devices, these bits must be set to zero when ETIMSK is written.

- **Bit 5 – TICIE3: Timer/Counter3, Input Capture Interrupt Enable**

When this bit is written to one, and the I-flag in the Status Register is set (interrupts globally enabled), the Timer/Counter3 Input Capture Interrupt is enabled. The corresponding interrupt vector (See “Interrupts” on page 59) is executed when the ICF3 flag, located in ETIFR, is set.

- **Bit 4 – OCIE3A: Timer/Counter3, Output Compare A Match Interrupt Enable**

When this bit is written to one, and the I-flag in the Status Register is set (interrupts globally enabled), the Timer/Counter3 Output Compare A Match Interrupt is enabled. The corresponding interrupt vector (See “Interrupts” on page 59) is executed when the OCF3A flag, located in ETIFR, is set.

- **Bit 3 – OCIE3B: Timer/Counter3, Output Compare B Match Interrupt Enable**

When this bit is written to one, and the I-flag in the Status Register is set (interrupts globally enabled), the Timer/Counter3 Output Compare B Match Interrupt is enabled. The corresponding interrupt vector (See “Interrupts” on page 59) is executed when the OCF3B flag, located in ETIFR, is set.

- **Bit 2 – TOIE3: Timer/Counter3, Overflow Interrupt Enable**

When this bit is written to one, and the I-flag in the Status Register is set (interrupts globally enabled), the Timer/Counter3 Overflow Interrupt is enabled. The corresponding interrupt vector (See “Interrupts” on page 59) is executed when the TOV3 flag, located in ETIFR, is set.

- **Bit 1 – OCIE3C: Timer/Counter3, Output Compare C Match Interrupt Enable**

When this bit is written to one, and the I-flag in the Status Register is set (interrupts globally enabled), the Timer/Counter3 Output Compare C Match Interrupt is enabled. The corresponding interrupt vector (See “Interrupts” on page 59) is executed when the OCF3C flag, located in ETIFR, is set.

- **Bit 0 – OCIE1C: Timer/Counter1, Output Compare C Match Interrupt Enable**

When this bit is written to one, and the I-flag in the Status Register is set (interrupts globally enabled), the Timer/Counter1 Output Compare C Match Interrupt is enabled. The corresponding interrupt vector (See “Interrupts” on page 59) is executed when the OCF1C flag, located in ETIFR, is set.

Timer/Counter Interrupt Flag Register – TIFR

| Bit | 7 | 6 | 5 | 4 | 3 | 2 | 1 | 0 | |
|---------------|------|------|------|-------|-------|------|------|------|------|
| | OCF2 | TOV2 | ICF1 | OCF1A | OCF1B | TOV1 | OCF0 | TOV0 | TIFR |
| Read/Write | R/W | R/W | R/W | R/W | R/W | R/W | R/W | R/W | |
| Initial Value | 0 | 0 | 0 | 0 | 0 | 0 | 0 | 0 | |

Note: This register contains flag bits for several Timer/Counters, but only timer 1 bits are described in this section. The remaining bits are described in their respective timer sections.

- **Bit 5 – ICF1: Timer/Counter1, Input Capture Flag**

This flag is set when a capture event occurs on the ICP1 pin. When the Input Capture Register (ICR1) is set by the WGMn3:0 to be used as the TOP value, the ICF1 flag is set when the counter reaches the TOP value.

ICF1 is automatically cleared when the Input Capture Interrupt vector is executed. Alternatively, ICF1 can be cleared by writing a logic one to its bit location.

- **Bit 4 – OCF1A: Timer/Counter1, Output Compare A Match Flag**

This flag is set in the timer clock cycle after the counter (TCNT1) value matches the Output Compare Register A (OCR1A).

Note that a forced output compare (FOC1A) strobe will not set the OCF1A flag.

OCF1A is automatically cleared when the Output Compare Match A interrupt vector is executed. Alternatively, OCF1A can be cleared by writing a logic one to its bit location.

- **Bit 3 – OCF1B: Timer/Counter1, Output Compare B Match Flag**

This flag is set in the timer clock cycle after the counter (TCNT1) value matches the Output Compare Register B (OCR1B).

Note that a forced output compare (FOC1B) strobe will not set the OCF1B flag.

OCF1B is automatically cleared when the Output Compare Match B interrupt vector is executed. Alternatively, OCF1B can be cleared by writing a logic one to its bit location.

- **Bit 2 – TOV1: Timer/Counter1, Overflow Flag**

The setting of this flag is dependent of the WGMn3:0 bits setting. In normal and CTC modes, the TOV1 flag is set when the timer overflows. Refer to Table 61 on page 134 for the TOV1 flag behavior when using another WGMn3:0 bit setting.

TOV1 is automatically cleared when the Timer/Counter1 Overflow interrupt vector is executed. Alternatively, TOV1 can be cleared by writing a logic one to its bit location.

Extended Timer/Counter Interrupt Flag Register – ETIFR

| | | | | | | | | | |
|---------------|-----|-----|------|-------|-------|------|-------|-------|-------|
| Bit | 7 | 6 | 5 | 4 | 3 | 2 | 1 | 0 | |
| | – | – | ICF3 | OCF3A | OCF3B | TOV3 | OCF3C | OCF1C | ETIFR |
| Read/Write | R/W | R/W | R/W | R/W | R/W | R/W | R/W | R/W | |
| Initial Value | 0 | 0 | 0 | 0 | 0 | 0 | 0 | 0 | |

- **Bit 7:6 – Reserved Bits**

These bits are reserved for future use. For ensuring compatibility with future devices, these bits must be set to zero when ETIFR is written.

- **Bit 5 – ICF3: Timer/Counter3, Input Capture Flag**

This flag is set when a capture event occurs on the ICP3 pin. When the Input Capture Register (ICR3) is set by the WGM3:0 to be used as the TOP value, the ICF3 flag is set when the counter reaches the TOP value.

ICF3 is automatically cleared when the Input Capture 3 interrupt vector is executed. Alternatively, ICF3 can be cleared by writing a logic one to its bit location.

- **Bit 4 – OCF3A: Timer/Counter3, Output Compare A Match Flag**

This flag is set in the timer clock cycle after the counter (TCNT3) value matches the Output Compare Register A (OCR3A).

Note that a forced output compare (FOC3A) strobe will not set the OCF3A flag.

OCF3A is automatically cleared when the Output Compare Match 3 A interrupt vector is executed. Alternatively, OCF3A can be cleared by writing a logic one to its bit location.

- **Bit 3 – OCF3B: Timer/Counter3, Output Compare B Match Flag**

This flag is set in the timer clock cycle after the counter (TCNT3) value matches the Output Compare Register B (OCR3B).

Note that a forced output compare (FOC3B) strobe will not set the OCF3B flag.

OCF3B is automatically cleared when the Output Compare Match 3 B interrupt vector is executed. Alternatively, OCF3B can be cleared by writing a logic one to its bit location.

- **Bit 2 – TOV3: Timer/Counter3, Overflow Flag**

The setting of this flag is dependent of the WGM3:0 bits setting. In normal and CTC modes, the TOV3 flag is set when the timer overflows. Refer to [Table 52 on page 104](#) for the TOV3 flag behavior when using another WGM3:0 bit setting.

TOV3 is automatically cleared when the Timer/Counter3 Overflow interrupt vector is executed. Alternatively, TOV3 can be cleared by writing a logic one to its bit location.

- **Bit 1 – OCF3C: Timer/Counter3, Output Compare C Match Flag**

This flag is set in the timer clock cycle after the counter (TCNT3) value matches the Output Compare Register C (OCR3C).

Note that a forced output compare (FOC3C) strobe will not set the OCF3C flag.

OCF3C is automatically cleared when the Output Compare Match 3 C interrupt vector is executed. Alternatively, OCF3C can be cleared by writing a logic one to its bit location.

- **Bit 0 – OCF1C: Timer/Counter1, Output Compare C Match Flag**

This flag is set in the timer clock cycle after the counter (TCNT1) value matches the Output Compare Register C (OCR1C).

Note that a forced output compare (FOC1C) strobe will not set the OCF1C flag.

OCF1C is automatically cleared when the Output Compare Match 1 C interrupt vector is executed. Alternatively, OCF1C can be cleared by writing a logic one to its bit location.

Timer/Counter3, Timer/Counter2, and Timer/Counter1 Prescalers

Timer/Counter3, Timer/Counter1, and Timer/Counter2 share the same prescaler module, but the Timer/Counters can have different prescaler settings. The description below applies to all of the mentioned Timer/Counters.

Internal Clock Source

The Timer/Counter can be clocked directly by the System Clock (by setting the CSn2:0 = 1). This provides the fastest operation, with a maximum Timer/Counter clock frequency equal to system clock frequency ($f_{CLK_I/O}$). Alternatively, one of four taps from the prescaler can be used as a clock source. The prescaled clock has a frequency of either $f_{CLK_I/O}/8$, $f_{CLK_I/O}/64$, $f_{CLK_I/O}/256$, or $f_{CLK_I/O}/1024$.

Prescaler Reset

The prescaler is free running, i.e., operates independently of the clock select logic of the Timer/Counter, and it is shared by Timer/Counter1, Timer/Counter2, and Timer/Counter3. Since the prescaler is not affected by the Timer/Counter's clock select, the state of the prescaler will have implications for situations where a prescaled clock is used. One example of prescaling artifacts occurs when the timer is enabled and clocked by the prescaler ($6 > CSn2:0 > 1$). The number of system clock cycles from when the timer is enabled to the first count occurs can be from 1 to N+1 system clock cycles, where N equals the prescaler divisor (8, 64, 256, or 1024).

It is possible to use the Prescaler Reset for synchronizing the Timer/Counter to program execution. However, care must be taken if the other Timer/Counter that shares the same prescaler also use prescaling. A Prescaler Reset will affect the prescaler period for all Timer/Counters it is connected to.

External Clock Source

An external clock source applied to the Tn pin can be used as Timer/Counter clock ($clk_{T1}/clk_{T2}/clk_{T3}$). The Tn pin is sampled once every system clock cycle by the pin synchronization logic. The synchronized (sampled) signal is then passed through the edge detector. Figure 59 shows a functional equivalent block diagram of the Tn synchronization and edge detector logic. The registers are clocked at the positive edge of the internal system clock ($clk_{I/O}$). The latch is transparent in the high period of the internal system clock.

The edge detector generates one $clk_{T1}/clk_{T2}/clk_{T3}$ pulse for each positive ($CSn2:0 = 7$) or negative ($CSn2:0 = 6$) edge it detects.

Figure 59. Tn Pin Sampling

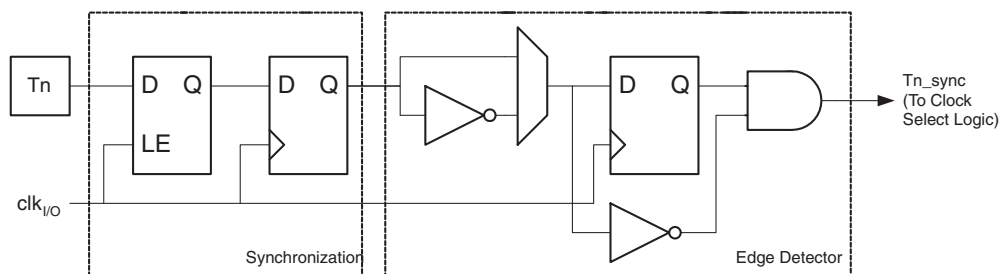

The synchronization and edge detector logic introduces a delay of 2.5 to 3.5 system clock cycles from an edge has been applied to the Tn pin to the counter is updated.

Enabling and disabling of the clock input must be done when Tn has been stable for at least one system clock cycle, otherwise it is a risk that a false Timer/Counter clock pulse is generated.

Each half period of the external clock applied must be longer than one system clock cycle to ensure correct sampling. The external clock must be guaranteed to have less than half the system clock frequency ($f_{ExtClk} < f_{clk_I/O}/2$) given a 50/50% duty cycle. Since the edge detector uses sampling, the maximum frequency of an external clock it can detect is half the sampling frequency (Nyquist sampling theorem). However, due to variation of the system clock frequency and duty cycle caused by Oscillator source (crystal, resonator, and capacitors) tolerances, it is recommended that maximum frequency of an external clock source is less than $f_{clk_I/O}/2.5$.

An external clock source can not be prescaled.

Figure 60. Prescaler for Timer/Counter1, Timer/Counter2, and Timer/Counter3



Note: The synchronization logic on the input pins (T3/T2/T1) is shown in [Figure 59](#).

Special Function IO Register – SFIOR

| Bit | 7 | 6 | 5 | 4 | 3 | 2 | 1 | 0 | |
|---------------|------------|---|---|---|-------------|------------|-------------|---------------|--------------|
| | TSM | – | – | – | ACME | PUD | PSR0 | PSR321 | SFIOR |
| Read/Write | R/W | R | R | R | R/W | R/W | R/W | R/W | |
| Initial Value | 0 | 0 | 0 | 0 | 0 | 0 | 0 | 0 | |

• Bit 7 – TSM: Timer/Counter Synchronization Mode

Writing the TSM bit to one activates the Timer/Counter Synchronization mode. In this mode, the value that is written to the PSR0 and PSR321 bits is kept, hence keeping the corresponding prescaler reset signals asserted. This ensures that the corresponding Timer/Counters are halted and can be configured to the same value without the risk of one of them advancing during configuration. When the TSM bit is written to zero, the PSR0 and PSR321 bits are cleared by hardware, and the Timer/Counters start counting simultaneously.

• Bit 0 – PSR321: Prescaler Reset Timer/Counter3, Timer/Counter2, and Timer/Counter1

When this bit is one, the Timer/Counter3, Timer/Counter1, and Timer/Counter2 prescaler will be reset. This bit is normally cleared immediately by hardware, except if the TSM bit is set. Note that Timer/Counter3, Timer/Counter1, and Timer/Counter2 share the same prescaler and a reset of this prescaler will affect all three timers.

8-bit Timer/Counter2 with PWM

Timer/Counter2 is a general purpose, single channel, 8-bit Timer/Counter module. The main features are:

- **Single Channel Counter**
- **Clear Timer on Compare Match (Auto Reload)**
- **Glitch-free, Phase Correct Pulse width Modulator (PWM)**
- **Frequency Generator**
- **External Event Counter**
- **10-bit Clock Prescaler**
- **Overflow and Compare Match Interrupt Sources (TOV2 and OCF2)**

Overview

A simplified block diagram of the 8-bit Timer/Counter is shown in Figure 61. For the actual placement of I/O pins, refer to “Pin Configurations” on page 2. CPU accessible I/O registers, including I/O bits and I/O pins, are shown in bold. The device-specific I/O register and bit locations are listed in the “8-bit Timer/Counter Register Description” on page 156.

Figure 61. 8-Bit Timer/Counter Block Diagram



Registers

The Timer/Counter (TCNT2) and Output Compare Register (OCR2) are 8-bit registers. Interrupt request (abbreviated to Int. Req. in the figure) signals are all visible in the Timer Interrupt Flag Register (TIFR). All interrupts are individually masked with the Timer Interrupt Mask Register (TIMSK). TIFR and TIMSK are not shown in the figure since these registers are shared by other timer units.

The Timer/Counter can be clocked internally, via the prescaler, or by an external clock source on the T2 pin. The Clock Select logic block controls which clock source and edge the Timer/Counter uses to increment (or decrement) its value. The Timer/Counter is inactive when no clock source is selected. The output from the clock select logic is referred to as the timer clock (clk_{T2}).

The double buffered Output Compare Register (OCR2) is compared with the Timer/Counter value at all times. The result of the compare can be used by the waveform generator to generate a PWM or variable frequency output on the Output Compare Pin (OC2). See “Output Compare Unit” on page 147. for details. The compare match event will also set the compare flag (OCF2) which can be used to generate an output compare interrupt request.

Definitions

Many register and bit references in this document are written in general form. A lower case “n” replaces the Timer/Counter number, in this case 2. However, when using the register or bit defines in a program, the precise form must be used (i.e., TCNT2 for accessing Timer/Counter2 counter value and so on).

The definitions in Table 63 are also used extensively throughout the document.

Table 63. Definitions

| | |
|--------|--|
| BOTTOM | The counter reaches the BOTTOM when it becomes 0x00. |
| MAX | The counter reaches its MAXimum when it becomes 0xFF (decimal 255). |
| TOP | The counter reaches the TOP when it becomes equal to the highest value in the count sequence. The TOP value can be assigned to be the fixed value 0xFF (MAX) or the value stored in the OCR2 Register. The assignment is dependent on the mode of operation. |

Timer/Counter Clock Sources

The Timer/Counter can be clocked by an internal or an external clock source. The clock source is selected by the clock select logic which is controlled by the clock select (CS22:0) bits located in the Timer/Counter Control Register (TCCR2). For details on clock sources and prescaler, see “Timer/Counter3, Timer/Counter2, and Timer/Counter1 Prescalers” on page 143.

Counter Unit

The main part of the 8-bit Timer/Counter is the programmable bi-directional counter unit. Figure 62 shows a block diagram of the counter and its surroundings.

Figure 62. Counter Unit Block Diagram



Signal description (internal signals):

- count** Increment or decrement TCNT2 by 1.
- direction** Select between increment and decrement.
- clear** Clear TCNT2 (set all bits to zero).
- clk_{Tn}** Timer/Counter clock, referred to as clk_{T0} in the following.
- top** Signalize that TCNT2 has reached maximum value.

bottom Signalize that TCNT2 has reached minimum value (zero).

Depending of the mode of operation used, the counter is cleared, incremented, or decremented at each timer clock (clk_{T2}). clk_{T2} can be generated from an external or internal clock source, selected by the clock select bits (CS22:0). When no clock source is selected (CS22:0 = 0) the timer is stopped. However, the TCNT2 value can be accessed by the CPU, regardless of whether clk_{T2} is present or not. A CPU write overrides (has priority over) all counter clear or count operations.

The counting sequence is determined by the setting of the WGM01 and WGM00 bits located in the Timer/Counter Control Register (TCCR2). There are close connections between how the counter behaves (counts) and how waveforms are generated on the output compare output OC2. For more details about advanced counting sequences and waveform generation, see “Modes of Operation” on page 149.

The Timer/Counter overflow (TOV2) flag is set according to the mode of operation selected by the WGM21:0 bits. TOV2 can be used for generating a CPU interrupt.

Output Compare Unit

The 8-bit comparator continuously compares TCNT2 with the Output Compare Register (OCR2). Whenever TCNT2 equals OCR2, the comparator signals a match. A match will set the output compare flag (OCF2) at the next timer clock cycle. If enabled (OCIE2 = 1 and global interrupt flag in SREG is set), the output compare flag generates an output compare interrupt. The OCF2 flag is automatically cleared when the interrupt is executed. Alternatively, the OCF2 flag can be cleared by software by writing a logical one to its I/O bit location. The waveform generator uses the match signal to generate an output according to operating mode set by the WGM21:0 bits and compare output mode (COM21:0) bits. The max and bottom signals are used by the waveform generator for handling the special cases of the extreme values in some modes of operation (see “Modes of Operation” on page 149). Figure 63 shows a block diagram of the output compare unit.

Figure 63. Output Compare Unit, Block Diagram



The OCR2 Register is double buffered when using any of the pulse width modulation (PWM) modes. For the normal and Clear Timer on Compare (CTC) modes of operation, the double buff-

ering is disabled. The double buffering synchronizes the update of the OCR2 Compare Register to either top or bottom of the counting sequence. The synchronization prevents the occurrence of odd-length, non-symmetrical PWM pulses, thereby making the output glitch-free.

The OCR2 Register access may seem complex, but this is not case. When the double buffering is enabled, the CPU has access to the OCR2 buffer Register, and if double buffering is disabled the CPU will access the OCR2 directly.

Force Output Compare

In non-PWM Waveform Generation modes, the match output of the comparator can be forced by writing a one to the force output compare (FOC2) bit. Forcing compare match will not set the OCF2 flag or reload/clear the timer, but the OC2 pin will be updated as if a real compare match had occurred (the COM21:0 bits settings define whether the OC2 pin is set, cleared or toggled).

Compare Match Blocking by TCNT2 Write

All CPU write operations to the TCNT2 Register will block any compare match that occur in the next timer clock cycle, even when the timer is stopped. This feature allows OCR2 to be initialized to the same value as TCNT2 without triggering an interrupt when the Timer/Counter clock is enabled.

Using the Output Compare Unit

Since writing TCNT2 in any mode of operation will block all compare matches for one timer clock cycle, there are risks involved when changing TCNT2 when using the output compare channel, independently of whether the Timer/Counter is running or not. If the value written to TCNT2 equals the OCR2 value, the compare match will be missed, resulting in incorrect waveform generation. Similarly, do not write the TCNT2 value equal to BOTTOM when the counter is downcounting.

The setup of the OC2 should be performed before setting the Data Direction Register for the port pin to output. The easiest way of setting the OC2 value is to use the Force Output Compare (FOC2) strobe bits in normal mode. The OC2 Register keeps its value even when changing between waveform generation modes.

Be aware that the COM21:0 bits are not double buffered together with the compare value. Changing the COM21:0 bits will take effect immediately.

Compare Match Output Unit

The Compare Output mode (COM21:0) bits have two functions. The waveform generator uses the COM21:0 bits for defining the output compare (OC2) state at the next compare match. Also, the COM21:0 bits control the OC2 pin output source. [Figure 64](#) shows a simplified schematic of the logic affected by the COM21:0 bit setting. The I/O registers, I/O bits, and I/O pins in the figure are shown in bold. Only the parts of the general I/O Port Control Registers (DDR and PORT) that are affected by the COM21:0 bits are shown. When referring to the OC2 state, the reference is for the internal OC2 Register, not the OC2 pin. If a System Reset occur, the OC2 Register is reset to “0”.

Figure 64. Compare Match Output Unit, Schematic



The general I/O port function is overridden by the output compare (OC2) from the waveform generator if either of the COM21:0 bits are set. However, the OC2 pin direction (input or output) is still controlled by the Data Direction Register (DDR) for the port pin. The Data Direction Register bit for the OC2 pin (DDR_OC2) must be set as output before the OC2 value is visible on the pin. The port override function is independent of the Waveform Generation mode.

The design of the output compare pin logic allows initialization of the OC2 state before the output is enabled. Note that some COM21:0 bit settings are reserved for certain modes of operation. See “8-bit Timer/Counter Register Description” on page 156.

Compare Output Mode and Waveform Generation

The waveform generator uses the COM21:0 bits differently in normal, CTC, and PWM modes. For all modes, setting the COM21:0 = 0 tells the waveform generator that no action on the OC2 Register is to be performed on the next compare match. For compare output actions in the non-PWM modes refer to Table 65 on page 157. For fast PWM mode, refer to Table 66 on page 157, and for phase correct PWM refer to Table 67 on page 157.

A change of the COM21:0 bits state will have effect at the first compare match after the bits are written. For non-PWM modes, the action can be forced to have immediate effect by using the FOC2 strobe bits.

Modes of Operation

The mode of operation, i.e., the behavior of the Timer/Counter and the Output Compare pins, is defined by the combination of the Waveform Generation mode (WGM21:0) and Compare Output mode (COM21:0) bits. The Compare Output mode bits do not affect the counting sequence, while the Waveform Generation mode bits do. The COM21:0 bits control whether the PWM output generated should be inverted or not (inverted or non-inverted PWM). For non-PWM modes the COM21:0 bits control whether the output should be set, cleared, or toggled at a compare match (See “Compare Match Output Unit” on page 148).

For detailed timing information refer to Figure 68, Figure 69, Figure 70, and Figure 71 in “Timer/Counter Timing Diagrams” on page 154.

Normal Mode

The simplest mode of operation is the normal mode (WGM21:0 = 0). In this mode the counting direction is always up (incrementing), and no counter clear is performed. The counter simply

overruns when it passes its maximum 8-bit value (TOP = 0xFF) and then restarts from the bottom (0x00). In normal operation the Timer/Counter overflow flag (TOV2) will be set in the same timer clock cycle as the TCNT2 becomes zero. The TOV2 flag in this case behaves like a ninth bit, except that it is only set, not cleared. However, combined with the timer overflow interrupt that automatically clears the TOV2 flag, the timer resolution can be increased by software. There are no special cases to consider in the normal mode, a new counter value can be written anytime.

The output compare unit can be used to generate interrupts at some given time. Using the output compare to generate waveforms in normal mode is not recommended, since this will occupy too much of the CPU time.

Clear Timer on Compare Match (CTC) Mode

In Clear Timer on Compare or CTC mode (WGM21:0 = 2), the OCR2 Register is used to manipulate the counter resolution. In CTC mode the counter is cleared to zero when the counter value (TCNT2) matches the OCR2. The OCR2 defines the top value for the counter, hence also its resolution. This mode allows greater control of the compare match output frequency. It also simplifies the operation of counting external events.

The timing diagram for the CTC mode is shown in [Figure 65](#). The counter value (TCNT2) increases until a compare match occurs between TCNT2 and OCR2 and then counter (TCNT2) is cleared.

Figure 65. CTC Mode, Timing Diagram

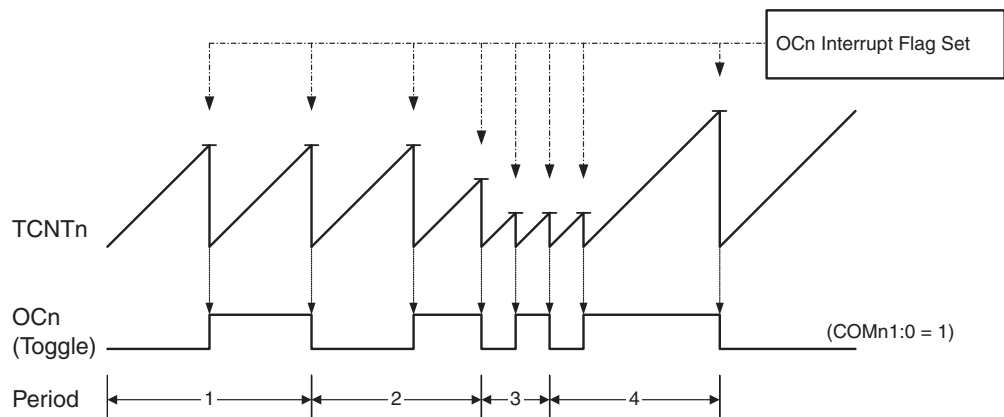

An interrupt can be generated each time the counter value reaches the TOP value by using the OCF2 flag. If the interrupt is enabled, the interrupt handler routine can be used for updating the TOP value. However, changing the TOP to a value close to BOTTOM when the counter is running with none or a low prescaler value must be done with care since the CTC mode does not have the double buffering feature. If the new value written to OCR2 is lower than the current value of TCNT2, the counter will miss the compare match. The counter will then have to count to its maximum value (0xFF) and wrap around starting at 0x00 before the compare match can occur.

For generating a waveform output in CTC mode, the OC2 output can be set to toggle its logical level on each compare match by setting the compare output mode bits to toggle mode (COM21:0 = 1). The OC2 value will not be visible on the port pin unless the data direction for the pin is set to output. The waveform generated will have a maximum frequency of $f_{OC2} = f_{clk_I/O}/2$ when OCR2 is set to zero (0x00). The waveform frequency is defined by the following equation:

$$f_{OCn} = \frac{f_{clk_I/O}}{2 \cdot N \cdot (1 + OCRn)}$$

The N variable represents the prescale factor (1, 8, 64, 256, or 1024).

As for the normal mode of operation, the TOV2 flag is set in the same timer clock cycle that the counter counts from MAX to 0x00.

Fast PWM Mode

The fast Pulse Width Modulation or fast PWM mode (WGM21:0 = 3) provides a high frequency PWM waveform generation option. The fast PWM differs from the other PWM option by its single-slope operation. The counter counts from BOTTOM to MAX then restarts from BOTTOM. In non-inverting Compare Output mode, the output compare (OC2) is cleared on the compare match between TCNT2 and OCR2, and set at BOTTOM. In inverting Compare Output mode, the output is set on compare match and cleared at BOTTOM. Due to the single-slope operation, the operating frequency of the fast PWM mode can be twice as high as the phase correct PWM mode that use dual-slope operation. This high frequency makes the fast PWM mode well suited for power regulation, rectification, and DAC applications. High frequency allows physically small sized external components (coils, capacitors), and therefore reduces total system cost.

In fast PWM mode, the counter is incremented until the counter value matches the MAX value. The counter is then cleared at the following timer clock cycle. The timing diagram for the fast PWM mode is shown in Figure 66. The TCNT2 value is in the timing diagram shown as a histogram for illustrating the single-slope operation. The diagram includes non-inverted and inverted PWM outputs. The small horizontal line marks on the TCNT2 slopes represent compare matches between OCR2 and TCNT2.

Figure 66. Fast PWM Mode, Timing Diagram

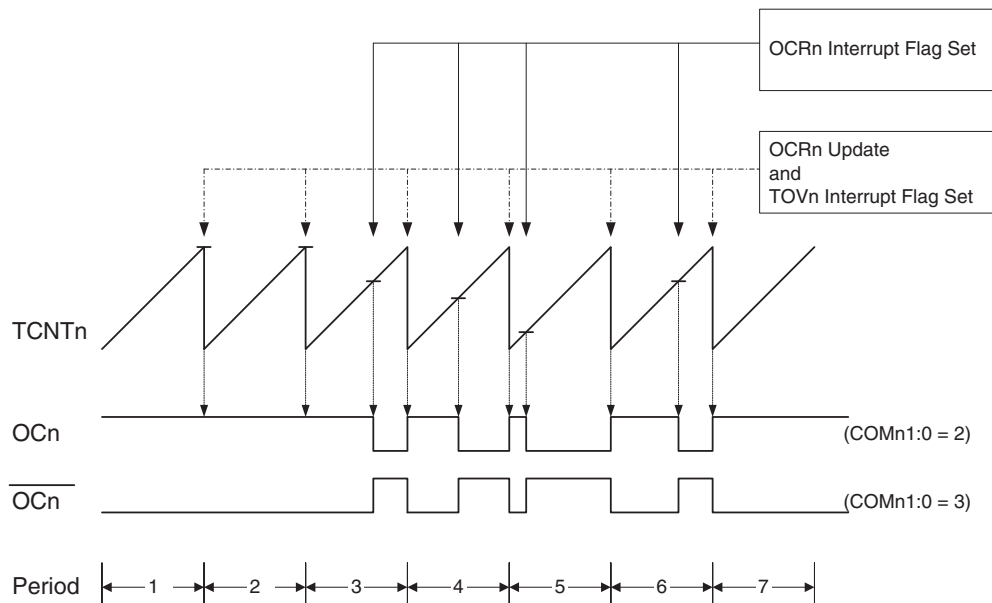

The Timer/Counter overflow flag (TOV2) is set each time the counter reaches Max. If the interrupt is enabled, the interrupt handler routine can be used for updating the compare value.

In fast PWM mode, the compare unit allows generation of PWM waveforms on the OC2 pin. Setting the COM21:0 bits to 2 will produce a non-inverted PWM and an inverted PWM output can be generated by setting the COM21:0 to 3 (see Table 66 on page 157). The actual OC2 value will only be visible on the port pin if the data direction for the port pin is set as output. The PWM waveform is generated by setting (or clearing) the OC2 Register at the compare match between OCR2 and TCNT2, and clearing (or setting) the OC2 Register at the timer clock cycle the counter is cleared (changes from MAX to BOTTOM).

The PWM frequency for the output can be calculated by the following equation:

$$f_{OCnPWM} = \frac{f_{clk_I/O}}{N \cdot 256}$$

The N variable represents the prescale factor (1, 8, 64, 256, or 1024).

The extreme values for the OCR2 Register represents special cases when generating a PWM waveform output in the fast PWM mode. If the OCR2 is set equal to BOTTOM, the output will be a narrow spike for each MAX+1 timer clock cycle. Setting the OCR2 equal to MAX will result in a constantly high or low output (depending on the polarity of the output set by the COM21:0 bits.)

A frequency (with 50% duty cycle) waveform output in fast PWM mode can be achieved by setting OC2 to toggle its logical level on each compare match (COM21:0 = 1). The waveform generated will have a maximum frequency of $f_{OC2} = f_{clk_I/O}/2$ when OCR2 is set to zero. This feature is similar to the OC2 toggle in CTC mode, except the double buffer feature of the output compare unit is enabled in the fast PWM mode.

Phase Correct PWM Mode

The phase correct PWM mode (WGM21:0 = 1) provides a high resolution phase correct PWM waveform generation option. The phase correct PWM mode is based on a dual-slope operation. The counter counts repeatedly from BOTTOM to MAX and then from MAX to BOTTOM. In non-inverting Compare Output mode, the output compare (OC2) is cleared on the compare match between TCNT2 and OCR2 while counting up, and set on the compare match while downcounting. In inverting Output Compare mode, the operation is inverted. The dual-slope operation has lower maximum operation frequency than single slope operation. However, due to the symmetric feature of the dual-slope PWM modes, these modes are preferred for motor control applications.

The PWM resolution for the phase correct PWM mode is fixed to 8 bits. In phase correct PWM mode the counter is incremented until the counter value matches Max. When the counter reaches MAX, it changes the count direction. The TCNT2 value will be equal to MAX for one timer clock cycle. The timing diagram for the phase correct PWM mode is shown on [Figure 67](#). The TCNT2 value is in the timing diagram shown as a histogram for illustrating the dual-slope operation. The diagram includes non-inverted and inverted PWM outputs. The small horizontal line marks on the TCNT2 slopes represent compare matches between OCR2 and TCNT2.

Figure 67. Phase Correct PWM Mode, Timing Diagram



The Timer/Counter Overflow Flag (TOV2) is set each time the counter reaches BOTTOM. The interrupt flag can be used to generate an interrupt each time the counter reaches the BOTTOM value.

In phase correct PWM mode, the compare unit allows generation of PWM waveforms on the OC2 pin. Setting the COM21:0 bits to 2 will produce a non-inverted PWM. An inverted PWM output can be generated by setting the COM21:0 to 3 (see [Table 67 on page 157](#)). The actual OC2 value will only be visible on the port pin if the data direction for the port pin is set as output. The PWM waveform is generated by clearing (or setting) the OC2 Register at the compare match between OCR2 and TCNT2 when the counter increments, and setting (or clearing) the OC2 Register at compare match between OCR2 and TCNT2 when the counter decrements. The PWM frequency for the output when using phase correct PWM can be calculated by the following equation:

$$f_{OCnPCPWM} = \frac{f_{clk_I/O}}{N \cdot 510}$$

The N variable represents the prescale factor (1, 8, 64, 256, or 1024).

The extreme values for the OCR2 Register represent special cases when generating a PWM waveform output in the phase correct PWM mode. If the OCR2 is set equal to BOTTOM, the output will be continuously low and if set equal to MAX the output will be continuously high for non-inverted PWM mode. For inverted PWM the output will have the opposite logic values.

At the very start of Period 2 in [Figure 67](#) OCn has a transition from high to low even though there is no Compare Match. The point of this transition is to guarantee symmetry around BOTTOM. There are two cases that give a transition without a Compare Match:

- OCR2A changes its value from MAX, like in [Figure 67](#). When the OCR2A value is MAX the OCn pin value is the same as the result of a down-counting Compare Match. To ensure symmetry around BOTTOM the OCn value at MAX must correspond to the result of an up-counting Compare Match.

- The timer starts counting from a value higher than the one in OCR2A, and for that reason misses the Compare Match and hence the OCN change that would have happened on the way up.

Timer/Counter Timing Diagrams

The Timer/Counter is a synchronous design and the timer clock (clk_{T2}) is therefore shown as a clock enable signal in the following figures. The figures include information on when interrupt flags are set. [Figure 68](#) contains timing data for basic Timer/Counter operation. The figure shows the count sequence close to the MAX value in all modes other than phase correct PWM mode.

Figure 68. Timer/Counter Timing Diagram, no Prescaling



[Figure 69](#) shows the same timing data, but with the prescaler enabled.

Figure 69. Timer/Counter Timing Diagram, with Prescaler ($f_{clk_{I/O}}/8$)



[Figure 70](#) shows the setting of OCF2 in all modes except CTC mode.

Figure 70. Timer/Counter Timing Diagram, Setting of OCF2, with Prescaler ($f_{clk_I/O}/8$)



Figure 71 shows the setting of OCF2 and the clearing of TCNT2 in CTC mode.

Figure 71. Timer/Counter Timing Diagram, Clear Timer on Compare Match Mode, with Prescaler ($f_{clk_I/O}/8$)



8-bit Timer/Counter Register Description

Timer/Counter Control Register – TCCR2

| | | | | | | | | | |
|---------------|-------------|--------------|--------------|--------------|--------------|-------------|-------------|-------------|-------|
| Bit | 7 | 6 | 5 | 4 | 3 | 2 | 1 | 0 | |
| | FOC2 | WGM20 | COM21 | COM20 | WGM21 | CS22 | CS21 | CS20 | TCCR2 |
| Read/Write | W | R/W | R/W | R/W | R/W | R/W | R/W | R/W | |
| Initial Value | 0 | 0 | 0 | 0 | 0 | 0 | 0 | 0 | |

- **Bit 7 – FOC2: Force Output Compare**

The FOC2 bit is only active when the WGM20 bit specifies a non-PWM mode. However, for ensuring compatibility with future devices, this bit must be set to zero when TCCR2 is written when operating in PWM mode. When writing a logical one to the FOC2 bit, an immediate compare match is forced on the waveform generation unit. The OC2 output is changed according to its COM21:0 bits setting. Note that the FOC2 bit is implemented as a strobe. Therefore it is the value present in the COM21:0 bits that determines the effect of the forced compare.

A FOC2 strobe will not generate any interrupt, nor will it clear the Timer in CTC mode using OCR2 as TOP.

The FOC2 bit is always read as zero.

- **Bit 6, 3 – WGM21:0: Waveform Generation Mode**

These bits control the counting sequence of the counter, the source for the maximum (TOP) counter value, and what type of waveform generation to be used. Modes of operation supported by the Timer/Counter unit are: Normal mode, Clear Timer on Compare match (CTC) mode, and two types of Pulse Width Modulation (PWM) modes. See [Table 64](#) and “Modes of Operation” on [page 149](#).

Table 64. Waveform Generation Mode Bit Description

| Mode | WGM21 (CTC2) | WGM20 (PWM2) | Timer/Counter Mode of Operation | TOP | Update of OCR2 at | TOV2 Flag Set on |
|------|--------------|--------------|---------------------------------|------|-------------------|------------------|
| 0 | 0 | 0 | Normal | 0xFF | Immediate | MAX |
| 1 | 0 | 1 | PWM, Phase Correct | 0xFF | TOP | BOTTOM |
| 2 | 1 | 0 | CTC | OCR2 | Immediate | MAX |
| 3 | 1 | 1 | Fast PWM | 0xFF | BOTTOM | MAX |

Note: The CTC2 and PWM2 bit definition names are now obsolete. Use the WGM21:0 definitions. However, the functionality and location of these bits are compatible with previous versions of the timer.

- **Bit 5:4 – COM21:0: Compare Match Output Mode**

These bits control the Output Compare Pin (OC2) behavior. If one or both of the COM21:0 bits are set, the OC2 output overrides the normal port functionality of the I/O pin it is connected to. However, note that the Data Direction Register (DDR) bit corresponding to the OC2 pin must be set in order to enable the output driver.

When OC2 is connected to the pin, the function of the COM21:0 bits depends on the WGM21:0 bit setting. [Table 65](#) shows the COM21:0 bit functionality when the WGM21:0 bits are set to a normal or CTC mode (non-PWM).

Table 65. Compare Output Mode, Non-PWM Mode

| COM21 | COM20 | Description |
|-------|-------|--|
| 0 | 0 | Normal port operation, OC2 disconnected. |
| 0 | 1 | Toggle OC2 on compare match |
| 1 | 0 | Clear OC2 on compare match |
| 1 | 1 | Set OC2 on compare match |

Table 66 shows the COM21:0 bit functionality when the WGM21:0 bits are set to fast PWM mode.

Table 66. Compare Output Mode, Fast PWM Mode⁽¹⁾

| COM21 | COM20 | Description |
|-------|-------|---|
| 0 | 0 | Normal port operation, OC2 disconnected. |
| 0 | 1 | Reserved |
| 1 | 0 | Clear OC2 on compare match, set OC2 at BOTTOM, (non-inverting mode) |
| 1 | 1 | Set OC2 on compare match, clear OC2 at BOTTOM, (inverting mode) |

Note: 1. A special case occurs when OCR2 equals TOP and COM21 is set. In this case, the compare match is ignored, but the set or clear is done at BOTTOM. See “Fast PWM Mode” on page 151 for more details.

Table 67 shows the COM21:0 bit functionality when the WGM21:0 bits are set to phase correct PWM mode.

Table 67. Compare Output Mode, Phase Correct PWM Mode⁽¹⁾

| COM21 | COM20 | Description |
|-------|-------|--|
| 0 | 0 | Normal port operation, OC2 disconnected. |
| 0 | 1 | Reserved |
| 1 | 0 | Clear OC2 on compare match when up-counting. Set OC2 on compare match when downcounting. |
| 1 | 1 | Set OC2 on compare match when up-counting. Clear OC2 on compare match when downcounting. |

Note: 1. A special case occurs when OCR2 equals TOP and COM21 is set. In this case, the compare match is ignored, but the set or clear is done at TOP. See “Phase Correct PWM Mode” on page 152 for more details.

• **Bit 2:0 – CS22:0: Clock Select**

The three clock select bits select the clock source to be used by the Timer/Counter.

Table 68. Clock Select Bit Description

| CS22 | CS21 | CS20 | Description |
|------|------|------|---|
| 0 | 0 | 0 | No clock source (Timer/Counter stopped) |
| 0 | 0 | 1 | clk _{I/O} /(No prescaling) |
| 0 | 1 | 0 | clk _{I/O} /8 (From prescaler) |
| 0 | 1 | 1 | clk _{I/O} /64 (From prescaler) |

Table 68. Clock Select Bit Description

| CS22 | CS21 | CS20 | Description |
|------|------|------|--|
| 1 | 0 | 0 | clk _{I/O} /256 (From prescaler) |
| 1 | 0 | 1 | clk _{I/O} /1024 (From prescaler) |
| 1 | 1 | 0 | External clock source on T2 pin. Clock on falling edge |
| 1 | 1 | 1 | External clock source on T2 pin. Clock on rising edge |

If external pin modes are used for the Timer/Counter2, transitions on the T2 pin will clock the counter even if the pin is configured as an output. This feature allows software control of the counting.

Timer/Counter Register – TCNT2

| Bit | 7 | 6 | 5 | 4 | 3 | 2 | 1 | 0 | |
|---------------|-------------------|-----|-----|-----|-----|-----|-----|-----|--------------|
| | TCNT2[7:0] | | | | | | | | TCNT2 |
| Read/Write | R/W | R/W | R/W | R/W | R/W | R/W | R/W | R/W | |
| Initial Value | 0 | 0 | 0 | 0 | 0 | 0 | 0 | 0 | |

The Timer/Counter Register gives direct access, both for read and write operations, to the Timer/Counter unit 8-bit counter. Writing to the TCNT2 Register blocks (removes) the compare match on the following timer clock. Modifying the counter (TCNT2) while the counter is running, introduces a risk of missing a compare match between TCNT2 and the OCR2 Register.

Output Compare Register – OCR2

| Bit | 7 | 6 | 5 | 4 | 3 | 2 | 1 | 0 | |
|---------------|------------------|-----|-----|-----|-----|-----|-----|-----|-------------|
| | OCR2[7:0] | | | | | | | | OCR2 |
| Read/Write | R/W | R/W | R/W | R/W | R/W | R/W | R/W | R/W | |
| Initial Value | 0 | 0 | 0 | 0 | 0 | 0 | 0 | 0 | |

The Output Compare Register contains an 8-bit value that is continuously compared with the counter value (TCNT2). A match can be used to generate an output compare interrupt, or to generate a waveform output on the OC2 pin.

Timer/Counter Interrupt Mask Register – TIMSK

| Bit | 7 | 6 | 5 | 4 | 3 | 2 | 1 | 0 | |
|---------------|--------------|--------------|---------------|---------------|---------------|--------------|--------------|--------------|--------------|
| | OCIE2 | TOIE2 | TICIE1 | OCIE1A | OCIE1B | TOIE1 | OCIE0 | TOIE0 | TIMSK |
| Read/Write | R/W | R/W | R/W | R/W | R/W | R/W | R/W | R/W | |
| Initial Value | 0 | 0 | 0 | 0 | 0 | 0 | 0 | 0 | |

- **Bit 7 – OCIE2: Timer/Counter2 Output Compare Match Interrupt Enable**

When the OCIE2 bit is written to one, and the I-bit in the Status Register is set (one), the Timer/Counter2 Compare Match interrupt is enabled. The corresponding interrupt is executed if a compare match in Timer/Counter2 occurs, i.e., when the OCF2 bit is set in the Timer/Counter Interrupt Flag Register – TIFR.

- **Bit 6 – TOIE2: Timer/Counter2 Overflow Interrupt Enable**

When the TOIE2 bit is written to one, and the I-bit in the Status Register is set (one), the Timer/Counter2 Overflow interrupt is enabled. The corresponding interrupt is executed if an overflow in Timer/Counter2 occurs, i.e., when the TOV2 bit is set in the Timer/Counter Interrupt Flag Register – TIFR.

Timer/Counter Interrupt Flag Register – TIFR

| | | | | | | | | | |
|---------------|------|------|------|-------|-------|------|------|------|------|
| Bit | 7 | 6 | 5 | 4 | 3 | 2 | 1 | 0 | |
| | OCF2 | TOV2 | ICF1 | OCF1A | OCF1B | TOV1 | OCF0 | TOV0 | TIFR |
| Read/Write | R/W | R/W | R/W | R/W | R/W | R/W | R/W | R/W | |
| Initial Value | 0 | 0 | 0 | 0 | 0 | 0 | 0 | 0 | |

- **Bit 7 – OCF2: Output Compare Flag 2**

The OCF2 bit is set (one) when a compare match occurs between the Timer/Counter2 and the data in OCR2 – Output Compare Register2. OCF2 is cleared by hardware when executing the corresponding interrupt handling vector. Alternatively, OCF2 is cleared by writing a logic one to the flag. When the I-bit in SREG, OCIE2 (Timer/Counter2 Compare Match Interrupt Enable), and OCF2 are set (one), the Timer/Counter2 Compare Match Interrupt is executed.

- **Bit 6 – TOV2: Timer/Counter2 Overflow Flag**

The bit TOV2 is set (one) when an overflow occurs in Timer/Counter2. TOV2 is cleared by hardware when executing the corresponding interrupt handling vector. Alternatively, TOV2 is cleared by writing a logic one to the flag. When the SREG I-bit, TOIE2 (Timer/Counter2 Overflow Interrupt Enable), and TOV2 are set (one), the Timer/Counter2 Overflow interrupt is executed. In PWM mode, this bit is set when Timer/Counter2 changes counting direction at \$00.

Output Compare Modulator (OCM1C2)

Overview

The Output Compare Modulator (OCM) allows generation of waveforms modulated with a carrier frequency. The modulator uses the outputs from the Output Compare Unit C of the 16-bit Timer/Counter1 and the Output Compare Unit of the 8-bit Timer/Counter2. For more details about these Timer/Counters see “16-bit Timer/Counter (Timer/Counter1 and Timer/Counter3)” on page 111 and “8-bit Timer/Counter2 with PWM” on page 145. Note that this feature is not available in ATmega103 compatibility mode.

Figure 72. Output Compare Modulator, Block Diagram

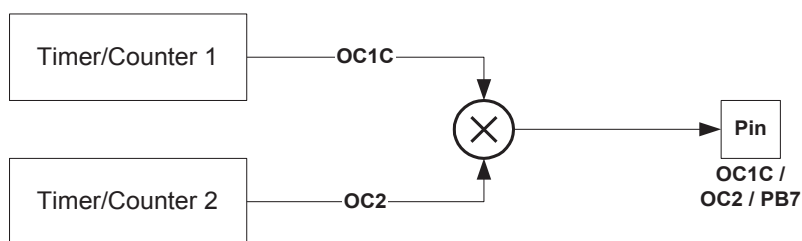

When the modulator is enabled, the two output compare channels are modulated together as shown in the block diagram (Figure 72).

Description

The Output Compare unit 1C and Output Compare unit 2 shares the PB7 port pin for output. The outputs of the Output Compare units (OC1C and OC2) overrides the normal PORTB7 Register when one of them is enabled (i.e., when COMnx1:0 is not equal to zero). When both OC1C and OC2 are enabled at the same time, the modulator is automatically enabled.

The functional equivalent schematic of the modulator is shown on Figure 73. The schematic includes part of the Timer/Counter units and the port B pin 7 output driver circuit.

Figure 73. Output Compare Modulator, Schematic

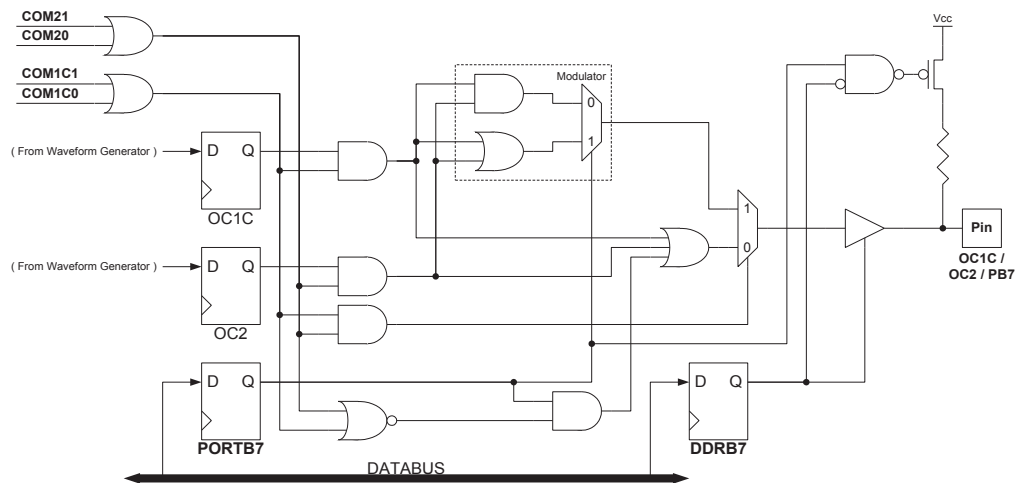

When the modulator is enabled the type of modulation (logical AND or OR) can be selected by the PORTB7 Register. Note that the DDRB7 controls the direction of the port independent of the COMnx1:0 bit setting.

Timing Example

Figure 74 illustrates the modulator in action. In this example the Timer/Counter1 is set to operate in fast PWM mode (non-inverted) and Timer/Counter2 uses CTC waveform mode with toggle Compare Output mode (COMnx1:0 = 1).

Figure 74. Output Compare Modulator, Timing Diagram



In this example, Timer/Counter2 provides the carrier, while the modulating signal is generated by the Output Compare unit C of the Timer/Counter1.

The resolution of the PWM signal (OC1C) is reduced by the modulation. The reduction factor is equal to the number of system clock cycles of one period of the carrier (OC2). In this example the resolution is reduced by a factor of two. The reason for the reduction is illustrated in Figure 74 at the second and third period of the PB7 output when PORTB7 equals zero. The period 2 high time is one cycle longer than the period 3 high time, but the result on the PB7 output is equal in both periods.

Serial Peripheral Interface – SPI

The Serial Peripheral Interface (SPI) allows high-speed synchronous data transfer between the Atmel AVR ATmega128 and peripheral devices or between several AVR devices. The ATmega128 SPI includes the following features:

- Full-duplex, Three-wire Synchronous Data Transfer
- Master or Slave Operation
- LSB First or MSB First Data Transfer
- Seven Programmable Bit Rates
- End of Transmission Interrupt Flag
- Write Collision Flag Protection
- Wake-up from Idle Mode
- Double Speed (CK/2) Master SPI Mode

Figure 75. SPI Block Diagram

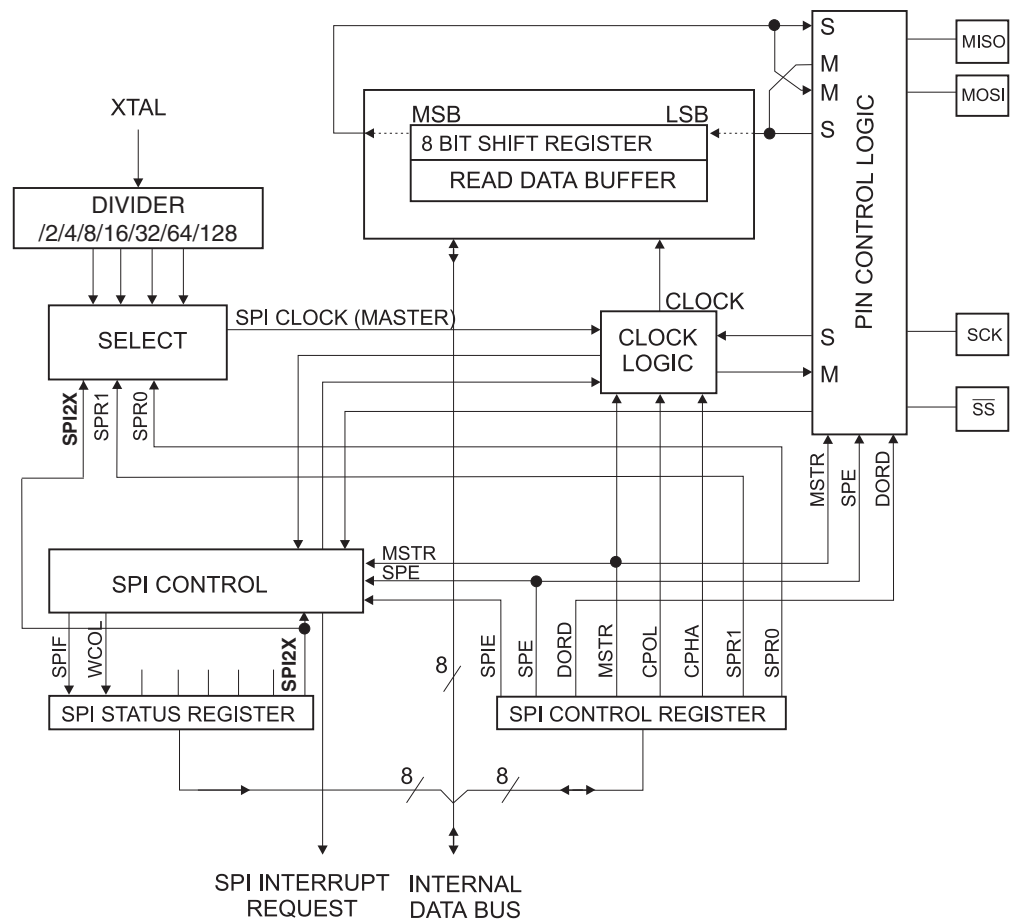

Note: Refer to [Figure 1 on page 2](#) and [Table 30 on page 73](#) for SPI pin placement.

The interconnection between Master and Slave CPUs with SPI is shown in [Figure 76](#). The system consists of two Shift Registers, and a Master clock generator. The SPI Master initiates the communication cycle when pulling low the Slave Select \overline{SS} pin of the desired Slave. Master and Slave prepare the data to be sent in their respective Shift Registers, and the Master generates the required clock pulses on the SCK line to interchange data. Data is always shifted from Master to Slave on the Master Out – Slave In, MOSI, line, and from Slave to Master on the Master In – Slave Out, MISO, line. After each data packet, the Master will synchronize the Slave by pulling high the Slave Select, \overline{SS} , line.

When configured as a Master, the SPI interface has no automatic control of the \overline{SS} line. This must be handled by user software before communication can start. When this is done, writing a byte to the SPI Data Register starts the SPI clock generator, and the hardware shifts the 8 bits into the Slave. After shifting one byte, the SPI clock generator stops, setting the end of transmission flag (SPIF). If the SPI interrupt enable bit (SPIE) in the SPCR Register is set, an interrupt is requested. The Master may continue to shift the next byte by writing it into SPDR, or signal the end of packet by pulling high the Slave Select, \overline{SS} line. The last incoming byte will be kept in the buffer register for later use.

When configured as a Slave, the SPI interface will remain sleeping with MISO tri-stated as long as the \overline{SS} pin is driven high. In this state, software may update the contents of the SPI Data Register, SPDR, but the data will not be shifted out by incoming clock pulses on the SCK pin until the \overline{SS} pin is driven low. As one byte has been completely shifted, the end of transmission flag, SPIF is set. If the SPI interrupt enable bit, SPIE, in the SPCR Register is set, an interrupt is requested. The Slave may continue to place new data to be sent into SPDR before reading the incoming data. The last incoming byte will be kept in the buffer register for later use.

Figure 76. SPI Master-Slave Interconnection



The system is single buffered in the transmit direction and double buffered in the receive direction. This means that bytes to be transmitted cannot be written to the SPI Data Register before the entire shift cycle is completed. When receiving data, however, a received character must be read from the SPI Data Register before the next character has been completely shifted in. Otherwise, the first byte is lost.

In SPI Slave mode, the control logic will sample the incoming signal of the SCK pin. To ensure correct sampling of the clock signal, the minimum low and high period should be:

Low period: Longer than 2 CPU clock cycles.

High period: Longer than 2 CPU clock cycles.

When the SPI is enabled, the data direction of the MOSI, MISO, SCK, and \overline{SS} pins is overridden according to [Table 69](#). For more details on automatic port overrides, refer to [“Alternate Port Functions” on page 70](#).

Table 69. SPI Pin Overrides⁽¹⁾

| Pin | Direction, Master SPI | Direction, Slave SPI |
|-----------------|-----------------------|----------------------|
| MOSI | User Defined | Input |
| MISO | Input | User Defined |
| SCK | User Defined | Input |
| \overline{SS} | User Defined | Input |

Note: 1. See “Alternate Functions of Port B” on page 73 for a detailed description of how to define the direction of the user defined SPI pins.

The following code examples show how to initialize the SPI as a Master and how to perform a simple transmission. DDR_SPI in the examples must be replaced by the actual data direction register controlling the SPI pins. DD_MOSI, DD_MISO and DD_SCK must be replaced by the actual data direction bits for these pins. For example, if MOSI is placed on pin PB5, replace DD_MOSI with DDB5 and DDR_SPI with DDRB.

Assembly Code Example⁽¹⁾

```

SPI_MasterInit:
    ; Set MOSI and SCK output, all others input
    ldi r17, (1<<DD_MOSI) | (1<<DD_SCK)
    out DDR_SPI, r17
    ; Enable SPI, Master, set clock rate fck/16
    ldi r17, (1<<SPE) | (1<<MSTR) | (1<<SPR0)
    out SPCR, r17
    ret

SPI_MasterTransmit:
    ; Start transmission of data (r16)
    out SPDR, r16
Wait_Transmit:
    ; Wait for transmission complete
    sbis SPSR, SPIF
    rjmp Wait_Transmit
    ret

```

C Code Example⁽¹⁾

```

void SPI_MasterInit(void)
{
    /* Set MOSI and SCK output, all others input */
    DDR_SPI = (1<<DD_MOSI) | (1<<DD_SCK);
    /* Enable SPI, Master, set clock rate fck/16 */
    SPCR = (1<<SPE) | (1<<MSTR) | (1<<SPR0);
}

void SPI_MasterTransmit(char cData)
{
    /* Start transmission */
    SPDR = cData;
    /* Wait for transmission complete */
    while (!(SPSR & (1<<SPIF)))
        ;
}

```

Note: 1. See “About Code Examples” on page 8.

The following code examples show how to initialize the SPI as a slave and how to perform a simple reception.

Assembly Code Example⁽¹⁾

```

SPI_SlaveInit:
    ; Set MISO output, all others input
    ldi r17, (1<<DD_MISO)
    out DDR_SPI, r17
    ; Enable SPI
    ldi r17, (1<<SPE)
    out SPCR, r17
    ret

SPI_SlaveReceive:
    ; Wait for reception complete
    sbis SPSR, SPIF
    rjmp SPI_SlaveReceive
    ; Read received data and return
    in r16, SPDR
    ret

```

C Code Example⁽¹⁾

```

void SPI_SlaveInit(void)
{
    /* Set MISO output, all others input */
    DDR_SPI = (1<<DD_MISO);
    /* Enable SPI */
    SPCR = (1<<SPE);
}

char SPI_SlaveReceive(void)
{
    /* Wait for reception complete */
    while (!(SPSR & (1<<SPIF)))
        ;
    /* Return data register */
    return SPDR;
}

```

Note: 1. See "About Code Examples" on page 8.

\overline{SS} Pin Functionality

Slave Mode

When the SPI is configured as a slave, the Slave Select (\overline{SS}) pin is always input. When \overline{SS} is held low, the SPI is activated, and MISO becomes an output if configured so by the user. All other pins are inputs. When \overline{SS} is driven high, all pins are inputs except MISO which can be user configured as an output, and the SPI is passive, which means that it will not receive incoming data. Note that the SPI logic will be reset once the \overline{SS} pin is driven high.

The \overline{SS} pin is useful for packet/byte synchronization to keep the slave bit counter synchronous with the master clock generator. When the \overline{SS} pin is driven high, the SPI slave will immediately reset the send and receive logic, and drop any partially received data in the Shift Register.

Master Mode

When the SPI is configured as a master (MSTR in SPCR is set), the user can determine the direction of the \overline{SS} pin.

If \overline{SS} is configured as an output, the pin is a general output pin which does not affect the SPI system. Typically, the pin will be driving the \overline{SS} pin of the SPI slave.

If \overline{SS} is configured as an input, it must be held high to ensure Master SPI operation. If the \overline{SS} pin is driven low by peripheral circuitry when the SPI is configured as a master with the \overline{SS} pin defined as an input, the SPI system interprets this as another master selecting the SPI as a slave and starting to send data to it. To avoid bus contention, the SPI system takes the following actions:

1. The MSTR bit in SPCR is cleared and the SPI system becomes a slave. As a result of the SPI becoming a slave, the MOSI and SCK pins become inputs.
2. The SPIF flag in SPSR is set, and if the SPI interrupt is enabled, and the I-bit in SREG is set, the interrupt routine will be executed.

Thus, when interrupt-driven SPI transmission is used in master mode, and there exists a possibility that \overline{SS} is driven low, the interrupt should always check that the MSTR bit is still set. If the MSTR bit has been cleared by a slave select, it must be set by the user to re-enable SPI master mode.

SPI Control Register – SPCR

| Bit | 7 | 6 | 5 | 4 | 3 | 2 | 1 | 0 | |
|---------------|-------------|-----|-----|-----|-----|-----|-----|-----|--|
| | SPCR | | | | | | | | |
| Read/Write | R/W | R/W | R/W | R/W | R/W | R/W | R/W | R/W | |
| Initial Value | 0 | 0 | 0 | 0 | 0 | 0 | 0 | 0 | |

- **Bit 7 – SPIE: SPI Interrupt Enable**

This bit causes the SPI interrupt to be executed if SPIF bit in the SPSR Register is set and the if the global interrupt enable bit in SREG is set.

- **Bit 6 – SPE: SPI Enable**

When the SPE bit is written to one, the SPI is enabled. This bit must be set to enable any SPI operations.

- **Bit 5 – DORD: Data Order**

When the DORD bit is written to one, the LSB of the data word is transmitted first.

When the DORD bit is written to zero, the MSB of the data word is transmitted first.

- **Bit 4 – MSTR: Master/Slave Select**

This bit selects Master SPI mode when written to one, and Slave SPI mode when written logic zero. If \overline{SS} is configured as an input and is driven low while MSTR is set, MSTR will be cleared,

and SPIF in SPSR will become set. The user will then have to set MSTR to re-enable SPI Master mode.

- **Bit 3 – CPOL: Clock Polarity**

When this bit is written to one, SCK is high when idle. When CPOL is written to zero, SCK is low when idle. Refer to [Figure 77](#) and [Figure 78](#) for an example. The CPOL functionality is summarized below:

Table 70. CPOL functionality

| CPOL | Leading edge | Trailing edge |
|------|--------------|---------------|
| 0 | Rising | Falling |
| 1 | Falling | Rising |

- **Bit 2 – CPHA: Clock Phase**

The settings of the clock phase bit (CPHA) determine if data is sampled on the leading (first) or trailing (last) edge of SCK. Refer to [Figure 77](#) and [Figure 78](#) for an example. The CPHA functionality is summarized below:

Table 71. CPHA functionality

| CPHA | Leading edge | Trailing edge |
|------|--------------|---------------|
| 0 | Sample | Setup |
| 1 | Setup | Sample |

- **Bits 1, 0 – SPR1, SPR0: SPI Clock Rate Select 1 and 0**

These two bits control the SCK rate of the device configured as a master. SPR1 and SPR0 have no effect on the slave. The relationship between SCK and the Oscillator Clock frequency f_{osc} is shown in the following table:

Table 72. Relationship Between SCK and the Oscillator Frequency

| SPI2X | SPR1 | SPR0 | SCK Frequency |
|-------|------|------|---------------|
| 0 | 0 | 0 | $f_{osc}/4$ |
| 0 | 0 | 1 | $f_{osc}/16$ |
| 0 | 1 | 0 | $f_{osc}/64$ |
| 0 | 1 | 1 | $f_{osc}/128$ |
| 1 | 0 | 0 | $f_{osc}/2$ |
| 1 | 0 | 1 | $f_{osc}/8$ |
| 1 | 1 | 0 | $f_{osc}/32$ |
| 1 | 1 | 1 | $f_{osc}/64$ |

SPI Status Register – SPSR

| | | | | | | | | | |
|---------------|-------------|-------------|---|---|---|---|---|--------------|--|
| Bit | 7 | 6 | 5 | 4 | 3 | 2 | 1 | 0 | |
| | SPSR | | | | | | | | |
| | SPIF | WCOL | – | – | – | – | – | SPI2X | |
| Read/Write | R | R | R | R | R | R | R | R/W | |
| Initial Value | 0 | 0 | 0 | 0 | 0 | 0 | 0 | 0 | |

- **Bit 7 – SPIF: SPI Interrupt Flag**

When a serial transfer is complete, the SPIF flag is set. An interrupt is generated if SPIE in SPCR is set and global interrupts are enabled. If \overline{SS} is an input and is driven low when the SPI is in Master mode, this will also set the SPIF flag. SPIF is cleared by hardware when executing the corresponding interrupt handling vector. Alternatively, the SPIF bit is cleared by first reading the SPI Status Register with SPIF set, then accessing the SPI Data Register (SPDR).

- **Bit 6 – WCOL: Write COLLision flag**

The WCOL bit is set if the SPI Data Register (SPDR) is written during a data transfer. The WCOL bit (and the SPIF bit) are cleared by first reading the SPI Status Register with WCOL set, and then accessing the SPI Data Register.

- **Bit 5..1 – Res: Reserved Bits**

These bits are reserved bits in the ATmega128 and will always read as zero.

- **Bit 0 – SPI2X: Double SPI Speed Bit**

When this bit is written logic one the SPI speed (SCK Frequency) will be doubled when the SPI is in Master mode (see [Table 72](#)). This means that the minimum SCK period will be 2 CPU clock periods. When the SPI is configured as Slave, the SPI is only guaranteed to work at $f_{osc}/4$ or lower.

The SPI interface on the ATmega128 is also used for program memory and EEPROM downloading or uploading. See [page 300](#) for SPI Serial Programming and verification.

SPI Data Register – SPDR

| | | | | | | | | | |
|---------------|-------------|-----|-----|-----|-----|-----|-----|------------|-----------|
| Bit | 7 | 6 | 5 | 4 | 3 | 2 | 1 | 0 | |
| | SPDR | | | | | | | | |
| | MSB | | | | | | | LSB | |
| Read/Write | R/W | R/W | R/W | R/W | R/W | R/W | R/W | R/W | |
| Initial Value | X | X | X | X | X | X | X | X | Undefined |

The SPI Data Register is a Read/Write Register used for data transfer between the register file and the SPI Shift Register. Writing to the register initiates data transmission. Reading the register causes the Shift Register Receive buffer to be read.

Data Modes

There are four combinations of SCK phase and polarity with respect to serial data, which are determined by control bits CPHA and CPOL. The SPI data transfer formats are shown in [Figure 77](#) and [Figure 78](#). Data bits are shifted out and latched in on opposite edges of the SCK signal, ensuring sufficient time for data signals to stabilize. This is clearly seen by summarizing [Table 70](#) and [Table 71](#), as done below:

Table 73. CPOL and CPHA Functionality

| | Leading edge | Trailing edge | SPI mode |
|--------------------|------------------|------------------|----------|
| CPOL = 0, CPHA = 0 | Sample (Rising) | Setup (Falling) | 0 |
| CPOL = 0, CPHA = 1 | Setup (Rising) | Sample (Falling) | 1 |
| CPOL = 1, CPHA = 0 | Sample (Falling) | Setup (Rising) | 2 |
| CPOL = 1, CPHA = 1 | Setup (Falling) | Sample (Rising) | 3 |

Figure 77. SPI Transfer Format with CPHA = 0



Figure 78. SPI Transfer Format with CPHA = 1

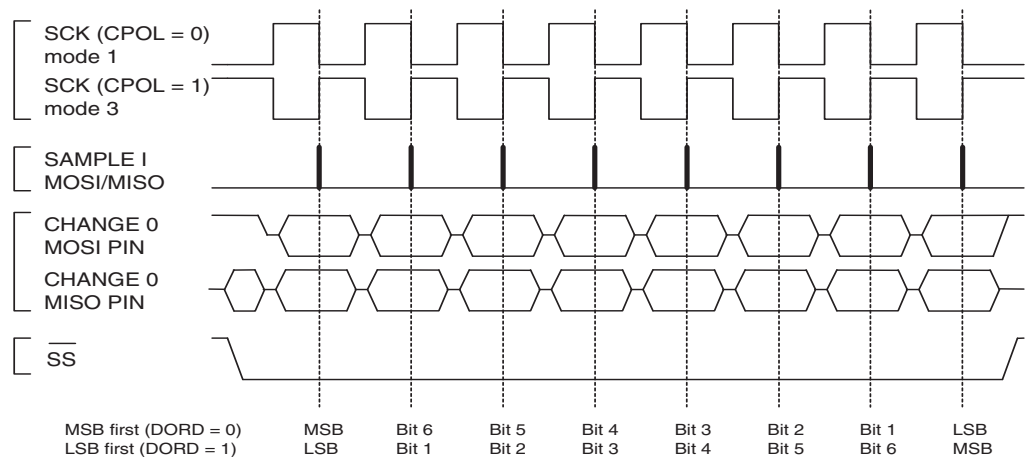

USART

The Universal Synchronous and Asynchronous serial Receiver and Transmitter (USART) is a highly flexible serial communication device. The main features are:

- **Full Duplex Operation (Independent Serial Receive and Transmit Registers)**
- **Asynchronous or Synchronous Operation**
- **Master or Slave Clocked Synchronous Operation**
- **High Resolution Baud Rate Generator**
- **Supports Serial Frames with 5, 6, 7, 8, or 9 Data Bits and 1 or 2 Stop Bits**
- **Odd or Even Parity Generation and Parity Check Supported by Hardware**
- **Data OverRun Detection**
- **Framing Error Detection**
- **Noise Filtering Includes False Start Bit Detection and Digital Low Pass Filter**
- **Three Separate Interrupts on TX Complete, TX Data Register Empty, and RX Complete**
- **Multi-processor Communication Mode**
- **Double Speed Asynchronous Communication Mode**

Dual USART

The ATmega128 has two USART's, USART0 and USART1. The functionality for both USART's is described below. USART0 and USART1 have different I/O registers as shown in "[Register Summary](#)" on page 362. Note that in ATmega103 compatibility mode, USART1 is not available, neither is the UBRR0H or UCRS0C Registers. This means that in ATmega103 compatibility mode, the ATmega128 supports asynchronous operation of USART0 only.

Overview

A simplified block diagram of the USART transmitter is shown in [Figure 79](#). CPU accessible I/O registers and I/O pins are shown in bold.

Figure 79. USART Block Diagram



Note: Refer to [Figure 1 on page 2](#), [Table 36 on page 77](#), and [Table 39 on page 80](#) for USART pin placement.

The dashed boxes in the block diagram separate the three main parts of the USART (listed from the top): Clock Generator, Transmitter, and Receiver. Control registers are shared by all units. The clock generation logic consists of synchronization logic for external clock input used by synchronous slave operation, and the baud rate generator. The XCK (Transfer Clock) pin is only used by Synchronous Transfer mode. The Transmitter consists of a single write buffer, a serial Shift Register, parity generator and control logic for handling different serial frame formats. The write buffer allows a continuous transfer of data without any delay between frames. The Receiver is the most complex part of the USART module due to its clock and data recovery units. The recovery units are used for asynchronous data reception. In addition to the recovery units, the receiver includes a parity checker, control logic, a Shift Register and a two level receive buffer (UDR). The receiver supports the same frame formats as the Transmitter, and can detect frame error, data overrun and parity errors.

AVR USART vs. AVR UART – Compatibility

The USART is fully compatible with the AVR UART regarding:

- Bit locations inside all USART registers
- Baud Rate Generation
- Transmitter Operation
- Transmit Buffer Functionality
- Receiver Operation

However, the receive buffering has two improvements that will affect the compatibility in some special cases:

- A second buffer register has been added. The two buffer registers operate as a circular FIFO buffer. Therefore the UDR must only be read once for each incoming data! More important is the fact that the error flags (FE and DOR) and the ninth data bit (RXB8) are buffered with the data in the receive buffer. Therefore the status bits must always be read before the UDR Register is read. Otherwise the error status will be lost since the buffer state is lost.
- The receiver Shift Register can now act as a third buffer level. This is done by allowing the received data to remain in the serial Shift Register (see [Figure 79](#)) if the buffer registers are full, until a new start bit is detected. The USART is therefore more resistant to Data OverRun (DOR) error conditions.

The following control bits have changed name, but have same functionality and register location:

- CHR9 is changed to UCSZ2
- OR is changed to DOR

Clock Generation

The clock generation logic generates the base clock for the transmitter and receiver. The USART supports four modes of clock operation: Normal Asynchronous, Double Speed Asynchronous, Master Synchronous, and Slave Synchronous mode. The UMSEL bit in USART Control and Status Register C (UCSRC) selects between asynchronous and synchronous operation. Double speed (Asynchronous mode only) is controlled by the U2X found in the UCSRA Register. When using Synchronous mode (UMSEL = 1), the Data Direction Register for the XCK pin (DDR_XCK) controls whether the clock source is internal (Master mode) or external (Slave mode). The XCK pin is only active when using Synchronous mode.

[Figure 80](#) shows a block diagram of the clock generation logic.

Figure 80. Clock Generation Logic, Block Diagram

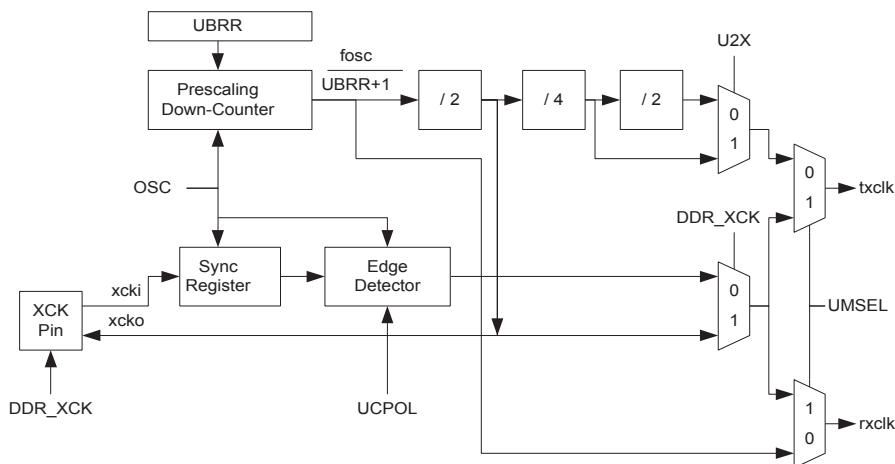

Signal description:

- txclk** Transmitter clock. (Internal Signal)
- rxclk** Receiver base clock. (Internal Signal)
- xcki** Input from XCK pin (internal Signal). Used for synchronous slave operation.
- xcko** Clock output to XCK pin (Internal Signal). Used for synchronous master operation.
- fosc** XTAL pin frequency (System Clock).

Internal Clock Generation – The Baud Rate Generator

Internal clock generation is used for the asynchronous and the synchronous master modes of operation. The description in this section refers to [Figure 80](#).

The USART Baud Rate Register (UBRR) and the down-counter connected to it function as a programmable prescaler or baud rate generator. The down-counter, running at system clock (fosc), is loaded with the UBRR value each time the counter has counted down to zero or when the UBRR Register is written. A clock is generated each time the counter reaches zero. This clock is the baud rate generator clock output (= fosc/(UBRR+1)). The transmitter divides the baud rate generator clock output by 2, 8, or 16 depending on mode. The baud rate generator output is used directly by the receiver's clock and data recovery units. However, the recovery units use a state machine that uses 2, 8, or 16 states depending on mode set by the state of the UMSEL, U2X and DDR_XCK bits.

[Table 74](#) contains equations for calculating the baud rate (in bits per second) and for calculating the UBRR value for each mode of operation using an internally generated clock source.

Table 74. Equations for Calculating Baud Rate Register Setting

| Operating Mode | Equation for Calculating Baud Rate ⁽¹⁾ | Equation for Calculating UBRR Value |
|--|---|-------------------------------------|
| Asynchronous Normal Mode (U2X = 0) | $BAUD = \frac{f_{OSC}}{16(UBRR + 1)}$ | $UBRR = \frac{f_{OSC}}{16BAUD} - 1$ |
| Asynchronous Double Speed Mode (U2X = 1) | $BAUD = \frac{f_{OSC}}{8(UBRR + 1)}$ | $UBRR = \frac{f_{OSC}}{8BAUD} - 1$ |
| Synchronous Master Mode | $BAUD = \frac{f_{OSC}}{2(UBRR + 1)}$ | $UBRR = \frac{f_{OSC}}{2BAUD} - 1$ |

Note: 1. The baud rate is defined to be the transfer rate in bit per second (bps).

BAUD Baud rate (in bits per second, bps)

f_{OSC} System Oscillator clock frequency

UBRR Contents of the UBRRH and UBRRL Registers, (0 - 4095)

Some examples of UBRR values for some system clock frequencies are found in [Table 82](#) (see [page 193](#)).

Double Speed Operation (U2X)

The transfer rate can be doubled by setting the U2X bit in UCSRA. Setting this bit only has effect for the asynchronous operation. Set this bit to zero when using synchronous operation.

Setting this bit will reduce the divisor of the baud rate divider from 16 to 8, effectively doubling the transfer rate for asynchronous communication. Note however that the receiver will in this case only use half the number of samples (reduced from 16 to 8) for data sampling and clock recovery, and therefore a more accurate baud rate setting and system clock are required when this mode is used. For the Transmitter, there are no downsides.

External Clock

External clocking is used by the synchronous slave modes of operation. The description in this section refers to [Figure 80](#) for details.

External clock input from the XCK pin is sampled by a synchronization register to minimize the chance of meta-stability. The output from the synchronization register must then pass through an edge detector before it can be used by the transmitter and receiver. This process introduces a two CPU clock period delay and therefore the maximum external XCK clock frequency is limited by the following equation:

$$f_{XCK} < \frac{f_{OSC}}{4}$$

Note that f_{osc} depends on the stability of the system clock source. It is therefore recommended to add some margin to avoid possible loss of data due to frequency variations.

Synchronous Clock Operation

When Synchronous mode is used (UMSEL = 1), the XCK pin will be used as either clock input (slave) or clock output (master). The dependency between the clock edges and data sampling or data change is the same. The basic principle is that data input (on RxD) is sampled at the opposite XCK clock edge of the edge the data output (TxD) is changed.

Figure 81. Synchronous Mode XCK Timing.



The UCPOL bit UCRSC selects which XCK clock edge is used for data sampling and which is used for data change. As [Figure 81](#) shows, when UCPOL is zero the data will be changed at rising XCK edge and sampled at falling XCK edge. If UCPOL is set, the data will be changed at falling XCK edge and sampled at rising XCK edge.

Frame Formats

A serial frame is defined to be one character of data bits with synchronization bits (start and stop bits), and optionally a parity bit for error checking. The USART accepts all 30 combinations of the following as valid frame formats:

- 1 start bit
- 5, 6, 7, 8, or 9 data bits
- no, even or odd parity bit
- 1 or 2 stop bits

A frame starts with the start bit followed by the least significant data bit. Then the next data bits, up to a total of nine, are succeeding, ending with the most significant bit. If enabled, the parity bit is inserted after the data bits, before the stop bits. When a complete frame is transmitted, it can be directly followed by a new frame, or the communication line can be set to an idle (high) state. Figure 82 illustrates the possible combinations of the frame formats. Bits inside brackets are optional.

Figure 82. Frame Formats



- St Start bit, always low.
- (n) Data bits (0 to 8).
- P Parity bit. Can be odd or even.
- Sp Stop bit, always high.
- IDLE No transfers on the communication line (RxD or TxD). An IDLE line must be high.

The frame format used by the USART is set by the UCSZ2:0, UPM1:0 and USBS bits in UCSRB and UCSRC. The receiver and transmitter use the same setting. Note that changing the setting of any of these bits will corrupt all ongoing communication for both the receiver and transmitter.

The USART Character SiZe (UCSZ2:0) bits select the number of data bits in the frame. The USART Parity mode (UPM1:0) bits enable and set the type of parity bit. The selection between one or two stop bits is done by the *USART Stop Bit Select* (USBS) bit. The receiver ignores the second stop bit. An FE (Frame Error) will therefore only be detected in the cases where the first stop bit is zero.

Parity Bit Calculation

The parity bit is calculated by doing an exclusive-or of all the data bits. If odd parity is used, the result of the exclusive or is inverted. The relation between the parity bit and data bits is as follows:

$$P_{even} = d_{n-1} \oplus \dots \oplus d_3 \oplus d_2 \oplus d_1 \oplus d_0 \oplus 0$$

$$P_{odd} = d_{n-1} \oplus \dots \oplus d_3 \oplus d_2 \oplus d_1 \oplus d_0 \oplus 1$$

- P_{even} Parity bit using even parity
- P_{odd} Parity bit using odd parity
- d_n Data bit n of the character

If used, the parity bit is located between the last data bit and first stop bit of a serial frame.

USART Initialization

The USART has to be initialized before any communication can take place. The initialization process normally consists of setting the baud rate, setting frame format and enabling the Transmitter or the Receiver depending on the usage. For interrupt driven USART operation, the global interrupt flag should be cleared (and interrupts globally disabled) when doing the initialization.

Before doing a re-initialization with changed baud rate or frame format, be sure that there are no ongoing transmissions during the period the registers are changed. The TXC flag can be used to check that the Transmitter has completed all transfers, and the RXC flag can be used to check that there are no unread data in the receive buffer. Note that the TXC flag must be cleared before each transmission (before UDR is written) if it is used for this purpose.

The following simple USART initialization code examples show one assembly and one C function that are equal in functionality. The examples assume asynchronous operation using polling (no interrupts enabled) and a fixed frame format. The baud rate is given as a function parameter. For the assembly code, the baud rate parameter is assumed to be stored in the r17:r16 registers.

Assembly Code Example⁽¹⁾

```

USART_Init:
    ; Set baud rate
    out  UBRRH, r17
    out  UBRRL, r16
    ; Enable receiver and transmitter
    ldi  r16, (1<<RXEN) | (1<<TXEN)
    out  UCSRB,r16
    ; Set frame format: 8data, 2stop bit
    ldi  r16, (1<<USBS) | (3<<UCSZ0)
    out  UCSRC,r16
    ret

```

C Code Example⁽¹⁾

```

#define FOSC 1843200// Clock Speed
#define BAUD 9600
#define MYUBRR FOSC/16/BAUD-1
void main( void )
{
    ...
    USART_Init ( MYUBRR );
    ...
}

void USART_Init( unsigned int ubrr )
{
    /* Set baud rate */
    UBRRH = (unsigned char) (ubrr>>8);
    UBRRL = (unsigned char)ubrr;
    /* Enable receiver and transmitter */
    UCSRB = (1<<RXEN) | (1<<TXEN);
    /* Set frame format: 8data, 2stop bit */
    UCSRC = (1<<USBS) | (3<<UCSZ0);
}

```

Note: 1. See “About Code Examples” on page 8.

More advanced initialization routines can be made that include frame format as parameters, disable interrupts and so on. However, many applications use a fixed setting of the baud and control registers, and for these types of applications the initialization code can be placed directly in the main routine, or be combined with initialization code for other I/O modules.

Data Transmission – The USART Transmitter

The USART Transmitter is enabled by setting the *Transmit Enable* (TXEN) bit in the UCSRB Register. When the Transmitter is enabled, the normal port operation of the TxD pin is overridden by the USART and given the function as the transmitter's serial output. The baud rate, mode of operation and frame format must be set up once before doing any transmissions. If synchronous operation is used, the clock on the XCK pin will be overridden and used as transmission clock.

Sending Frames with 5 to 8 Data Bit

A data transmission is initiated by loading the transmit buffer with the data to be transmitted. The CPU can load the transmit buffer by writing to the UDR I/O location. The buffered data in the transmit buffer will be moved to the Shift Register when the Shift Register is ready to send a new frame. The Shift Register is loaded with new data if it is in idle state (no ongoing transmission) or immediately after the last stop bit of the previous frame is transmitted. When the Shift Register is loaded with new data, it will transfer one complete frame at the rate given by the baud register, U2X bit or by XCK depending on mode of operation.

The following code examples show a simple USART transmit function based on polling of the *Data Register Empty* (UDRE) flag. When using frames with less than eight bits, the most significant bits written to the UDR are ignored. The USART has to be initialized before the function can be used. For the assembly code, the data to be sent is assumed to be stored in Register R16

Assembly Code Example⁽¹⁾

```
USART_Transmit:
    ; Wait for empty transmit buffer
    sbis UCSRA,UDRE
    rjmp USART_Transmit
    ; Put data (r16) into buffer, sends the data
    out  UDR,r16
    ret
```

C Code Example⁽¹⁾

```
void USART_Transmit( unsigned char data )
{
    /* Wait for empty transmit buffer */
    while ( !( UCSRA & (1<<UDRE)) )
        ;
    /* Put data into buffer, sends the data */
    UDR = data;
}
```

Note: 1. See "About Code Examples" on page 8..

The function simply waits for the transmit buffer to be empty by checking the UDRE flag, before loading it with new data to be transmitted. If the data register empty interrupt is utilized, the interrupt routine writes the data into the buffer.

Sending Frames with 9 Data Bit

If 9-bit characters are used (UCSZ = 7), the ninth bit must be written to the TXB8 bit in UCSRB before the low byte of the character is written to UDR. The following code examples show a transmit function that handles 9 bit characters. For the assembly code, the data to be sent is assumed to be stored in Registers R17:R16.

Assembly Code Example⁽¹⁾

```

USART_Transmit:
    ; Wait for empty transmit buffer
    sbis UCSRA,UDRE
    rjmp USART_Transmit
    ; Copy 9th bit from r17 to TXB8
    cbi UCSRB, TXB8
    sbrc r17,0
    sbi UCSRB, TXB8
    ; Put LSB data (r16) into buffer, sends the data
    out UDR,r16
    ret
    
```

C Code Example

```

void USART_Transmit( unsigned int data )
{
    /* Wait for empty transmit buffer */
    while ( !( UCSRA & (1<<UDRE)) )
        ;
    /* Copy 9th bit to TXB8 */
    UCSRB &= ~(1<<TXB8);
    if ( data & 0x0100 )
        UCSRB |= (1<<TXB8);
    /* Put data into buffer, sends the data */
    UDR = data;
}
    
```

Note: 1. These transmit functions are written to be general functions. They can be optimized if the contents of the UCSRB is static. I.e., only the TXB8 bit of the UCSRB Register is used after initialization.

For I/O registers located in extended I/O map, “IN”, “OUT”, “SBIS”, “SBIC”, “CBI”, and “SBI” instructions must be replaced with instructions that allow access to extended I/O. Typically “LDS” and “STS” combined with “SBR”, “SBRC”, “SBR”, and “CBR”.

The ninth bit can be used for indicating an address frame when using multi processor communication mode or for other protocol handling as for example synchronization.

Transmitter Flags and Interrupts

The USART Transmitter has two flags that indicate its state: USART Data Register Empty (UDRE) and Transmit Complete (TXC). Both flags can be used for generating interrupts.

The Data Register Empty (UDRE) flag indicates whether the transmit buffer is ready to receive new data. This bit is set when the transmit buffer is empty, and cleared when the transmit buffer contains data to be transmitted that has not yet been moved into the Shift Register. For compatibility with future devices, always write this bit to zero when writing the UCSRA Register.

When the Data Register empty Interrupt Enable (UDRIE) bit in UCSRB is written to one, the USART Data Register Empty Interrupt will be executed as long as UDRE is set (provided that global interrupts are enabled). UDRE is cleared by writing UDR. When interrupt-driven data

transmission is used, the data register empty Interrupt routine must either write new data to UDR in order to clear UDRE or disable the data register empty interrupt, otherwise a new interrupt will occur once the interrupt routine terminates.

The Transmit Complete (TXC) flag bit is set one when the entire frame in the Transmit Shift Register has been shifted out and there are no new data currently present in the transmit buffer. The TXC flag bit is automatically cleared when a transmit complete interrupt is executed, or it can be cleared by writing a one to its bit location. The TXC flag is useful in half-duplex communication interfaces (like the RS485 standard), where a transmitting application must enter receive mode and free the communication bus immediately after completing the transmission.

When the Transmit Complete Interrupt Enable (TXCIE) bit in UCSRB is set, the USART Transmit Complete Interrupt will be executed when the TXC flag becomes set (provided that global interrupts are enabled). When the transmit complete interrupt is used, the interrupt handling routine does not have to clear the TXC flag, this is done automatically when the interrupt is executed.

Parity Generator

The parity generator calculates the parity bit for the serial frame data. When parity bit is enabled (UPM1 = 1), the transmitter control logic inserts the parity bit between the last data bit and the first stop bit of the frame that is sent.

Disabling the Transmitter

The disabling of the Transmitter (setting the TXEN to zero) will not become effective until ongoing and pending transmissions are completed, i.e., when the Transmit Shift Register and Transmit Buffer register do not contain data to be transmitted. When disabled, the Transmitter will no longer override the TxD pin.

Data Reception – The USART Receiver

The USART Receiver is enabled by writing the Receive Enable (RXEN) bit in the UCSRB Register to one. When the receiver is enabled, the normal pin operation of the RxD pin is overridden by the USART and given the function as the receiver's serial input. The baud rate, mode of operation and frame format must be set up once before any serial reception can be done. If synchronous operation is used, the clock on the XCK pin will be used as transfer clock.

Receiving Frames with 5 to 8 Data Bits

The Receiver starts data reception when it detects a valid start bit. Each bit that follows the start bit will be sampled at the baud rate or XCK clock, and shifted into the Receive Shift Register until the first stop bit of a frame is received. A second stop bit will be ignored by the receiver. When the first stop bit is received, i.e., a complete serial frame is present in the Receive Shift Register, the contents of the Shift Register will be moved into the receive buffer. The receive buffer can then be read by reading the UDR I/O location.

The following code example shows a simple USART receive function based on polling of the Receive Complete (RXC) flag. When using frames with less than eight bits the most significant bits of the data read from the UDR will be masked to zero. The USART has to be initialized before the function can be used.

Assembly Code Example⁽¹⁾

```

USART_Receive:
    ; Wait for data to be received
    sbis UCSRA, RXC
    rjmp USART_Receive
    ; Get and return received data from buffer
    in    r16, UDR
    ret
    
```

C Code Example⁽¹⁾

```

unsigned char USART_Receive( void )
{
    /* Wait for data to be received */
    while ( !(UCSRA & (1<<RXC)) )
        ;
    /* Get and return received data from buffer */
    return UDR;
}
    
```

Note: 1. See “About Code Examples” on page 8.
The function simply waits for data to be present in the receive buffer by checking the RXC flag, before reading the buffer and returning the value.

Receiving Frames with 9 Data Bits

If 9-bit characters are used (UCSZ=7) the ninth bit must be read from the RXB8 bit in UCSRB **before** reading the low bits from the UDR. This rule applies to the FE, DOR and UPE status flags as well. Read status from UCSRA, then data from UDR. Reading the UDR I/O location will change the state of the receive buffer FIFO and consequently the TXB8, FE, DOR, and UPE bits, which all are stored in the FIFO, will change.

The following code example shows a simple USART receive function that handles both nine bit characters and the status bits.

Assembly Code Example⁽¹⁾

```

USART_Receive:
    ; Wait for data to be received
    sbis UCSRA, RXC
    rjmp USART_Receive
    ; Get status and 9th bit, then data from buffer
    in    r18, UCSRA
    in    r17, UCSRB
    in    r16, UDR
    ; If error, return -1
    andi r18, (1<<FE) | (1<<DOR) | (1<<UPE)
    breq USART_ReceiveNoError
    ldi   r17, HIGH(-1)
    ldi   r16, LOW(-1)
USART_ReceiveNoError:
    ; Filter the 9th bit, then return
    lsr   r17
    andi  r17, 0x01
    ret
    
```

C Code Example⁽¹⁾

```

unsigned int USART_Receive( void )
{
    unsigned char status, resh, resl;
    /* Wait for data to be received */
    while ( !(UCSRA & (1<<RXC)) )
        ;
    /* Get status and 9th bit, then data */
    /* from buffer */
    status = UCSRA;
    resh = UCSRB;
    resl = UDR;
    /* If error, return -1 */
    if ( status & (1<<FE) | (1<<DOR) | (1<<UPE) )
        return -1;
    /* Filter the 9th bit, then return */
    resh = (resh >> 1) & 0x01;
    return ((resh << 8) | resl);
}
    
```

- Note: 1. See [“About Code Examples” on page 8](#).
The receive function example reads all the I/O registers into the register file before any computation is done. This gives an optimal receive buffer utilization since the buffer location read will be free to accept new data as early as possible.

Receive Complete Flag and Interrupt

The USART Receiver has one flag that indicates the receiver state.

The Receive Complete (RXC) flag indicates if there are unread data present in the receive buffer. This flag is one when unread data exist in the receive buffer, and zero when the receive buffer is empty (i.e., does not contain any unread data). If the Receiver is disabled (RXEN = 0), the receive buffer will be flushed and consequently the RXC bit will become zero.

When the Receive Complete Interrupt Enable (RXCIE) in UCSRB is set, the USART Receive Complete Interrupt will be executed as long as the RXC flag is set (provided that global interrupts are enabled). When interrupt-driven data reception is used, the receive complete routine must read the received data from UDR in order to clear the RXC flag, otherwise a new interrupt will occur once the interrupt routine terminates.

Receiver Error Flags

The USART receiver has three error flags: Frame Error (FE), Data OverRun (DOR) and Parity Error (UPE). All can be accessed by reading UCSRA. Common for the error flags is that they are located in the receive buffer together with the frame for which they indicate the error status. Due to the buffering of the error flags, the UCSRA must be read before the receive buffer (UDR), since reading the UDR I/O location changes the buffer read location. Another equality for the error flags is that they can not be altered by software doing a write to the flag location. However, all flags must be set to zero when the UCSRA is written for upward compatibility of future USART implementations. None of the error flags can generate interrupts.

The Frame Error (FE) flag indicates the state of the first stop bit of the next readable frame stored in the receive buffer. The FE flag is zero when the stop bit was correctly read (as one), and the FE flag will be one when the stop bit was incorrect (zero). This flag can be used for detecting out-of-sync conditions, detecting break conditions and protocol handling. The FE flag is not affected by the setting of the USBS bit in UCSRC since the receiver ignores all, except for the first, stop bits. For compatibility with future devices, always set this bit to zero when writing to UCSRA.

The Data OverRun (DOR) flag indicates data loss due to a receiver buffer full condition. A data overrun occurs when the receive buffer is full (two characters), it is a new character waiting in the Receive Shift Register, and a new start bit is detected. If the DOR flag is set there was one or more serial frame lost between the frame last read from UDR, and the next frame read from UDR. For compatibility with future devices, always write this bit to zero when writing to UCSRA. The DOR flag is cleared when the frame received was successfully moved from the Shift Register to the receive buffer.

The Parity Error (UPE) flag indicates that the next frame in the receive buffer had a parity error when received. If parity check is not enabled the UPE bit will always be read zero. For compatibility with future devices, always set this bit to zero when writing to UCSRA. For more details see [“Parity Bit Calculation” on page 175](#) and [“Parity Checker” on page 183](#).

Parity Checker

The parity checker is active when the high USART Parity mode (UPM1) bit is set. Type of parity check to be performed (odd or even) is selected by the UPM0 bit. When enabled, the parity checker calculates the parity of the data bits in incoming frames and compares the result with the parity bit from the serial frame. The result of the check is stored in the receive buffer together with the received data and stop bits. The Parity Error (UPE) flag can then be read by software to check if the frame had a Parity Error.

The UPE bit is set if the next character that can be read from the receive buffer had a parity Error when received and the parity checking was enabled at that point (UPM1 = 1). This bit is valid until the Receive buffer (UDR) is read.

Disabling the Receiver

In contrast to the Transmitter, disabling of the Receiver will be immediate. Data from ongoing receptions will therefore be lost. When disabled (i.e., the RXEN is set to zero) the receiver will no longer override the normal function of the RxD port pin. The receiver buffer FIFO will be flushed when the receiver is disabled. Remaining data in the buffer will be lost

Flushing the Receive Buffer

The receiver buffer FIFO will be flushed when the receiver is disabled, i.e. the buffer will be emptied of its contents. Unread data will be lost. If the buffer has to be flushed during normal operation, due to for instance an error condition, read the UDR I/O location until the RXC flag is cleared. The following code example shows how to flush the receive buffer.

| |
|--|
| <p>Assembly Code Example⁽¹⁾</p> <pre> USART_Flush: sbis UCSRA, RXC ret in r16, UDR rjmp USART_Flush </pre> |
| <p>C Code Example⁽¹⁾</p> <pre> void USART_Flush(void) { unsigned char dummy; while (UCSRA & (1<<RXC)) dummy = UDR; } </pre> |

Note: 1. [“About Code Examples” on page 8.](#)

The USART includes a clock recovery and a data recovery unit for handling asynchronous data reception. The clock recovery logic is used for synchronizing the internally generated baud rate clock to the incoming asynchronous serial frames at the RxD pin. The data recovery logic samples and low pass filters each incoming bit, thereby improving the noise immunity of the receiver. The asynchronous reception operational range depends on the accuracy of the internal baud rate clock, the rate of the incoming frames, and the frame size in number of bits.

Asynchronous Clock Recovery

The clock recovery logic synchronizes internal clock to the incoming serial frames. [Figure 83](#) illustrates the sampling process of the start bit of an incoming frame. The sample rate is 16 times the baud rate for normal mode, and 8 times the baud rate for Double Speed mode. The horizontal arrows illustrate the synchronization variation due to the sampling process. Note the larger time variation when using the double speed mode ($U2X = 1$) of operation. Samples denoted zero are samples done when the RxD line is idle (i.e., no communication activity).

Figure 83. Start Bit Sampling

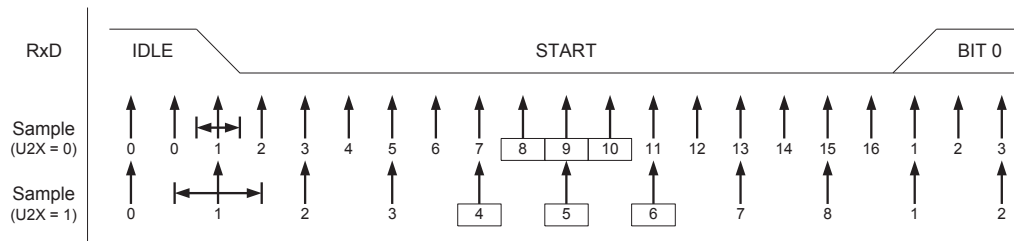

When the clock recovery logic detects a high (idle) to low (start) transition on the RxD line, the start bit detection sequence is initiated. Let sample 1 denote the first zero-sample as shown in the figure. The clock recovery logic then uses samples 8, 9, and 10 for normal mode, and samples 4, 5, and 6 for Double Speed mode (indicated with sample numbers inside boxes on the figure), to decide if a valid start bit is received. If two or more of these three samples have logical high levels (the majority wins), the start bit is rejected as a noise spike and the receiver starts looking for the next high to low-transition. If however, a valid start bit is detected, the clock recovery logic is synchronized and the data recovery can begin. The synchronization process is repeated for each start bit.

Asynchronous Data Recovery

When the receiver clock is synchronized to the start bit, the data recovery can begin. The data recovery unit uses a state machine that has 16 states for each bit in normal mode and 8 states for each bit in Double Speed mode. [Figure 84](#) shows the sampling of the data bits and the parity bit. Each of the samples is given a number that is equal to the state of the recovery unit.

Figure 84. Sampling of Data and Parity Bit

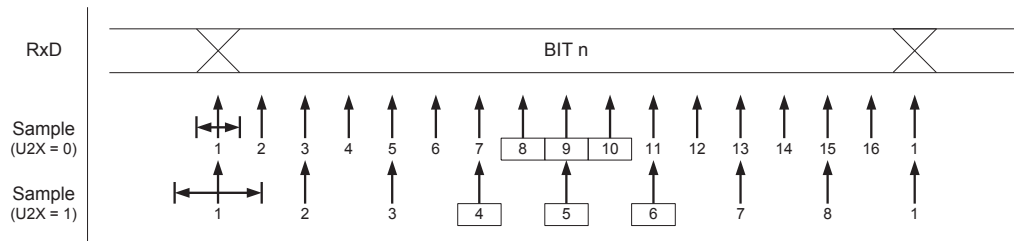

The decision of the logic level of the received bit is taken by doing a majority voting of the logic value to the three samples in the center of the received bit. The center samples are emphasized on the figure by having the sample number inside boxes. The majority voting process is done as follows: If two or all three samples have high levels, the received bit is registered to be a logic 1. If two or all three samples have low levels, the received bit is registered to be a logic 0. This majority voting process acts as a low pass filter for the incoming signal on the RxD pin. The recovery process is then repeated until a complete frame is received. Including the first stop bit. Note that the receiver only uses the first stop bit of a frame. [Figure 85](#) shows the sampling of the stop bit and the earliest possible beginning of the start bit of the next frame.

Figure 85. Stop Bit Sampling and Next Start Bit Sampling



The same majority voting is done to the stop bit as done for the other bits in the frame. If the stop bit is registered to have a logic 0 value, the Frame Error (FE) flag will be set.

A new high to low transition indicating the start bit of a new frame can come right after the last of the bits used for majority voting. For Normal Speed mode, the first low level sample can be at point marked (A) in Figure 85. For Double Speed mode the first low level must be delayed to (B). (C) marks a stop bit of full length. The early start bit detection influences the operational range of the receiver.

Asynchronous Operational Range

The operational range of the Receiver is dependent on the mismatch between the received bit rate and the internally generated baud rate. If the Transmitter is sending frames at too fast or too slow bit rates, or the internally generated baud rate of the receiver does not have a similar (see Table 75) base frequency, the Receiver will not be able to synchronize the frames to the start bit.

The following equations can be used to calculate the ratio of the incoming data rate and internal receiver baud rate.

$$R_{slow} = \frac{(D + 1)S}{S - 1 + D \cdot S + S_F} \qquad R_{fast} = \frac{(D + 2)S}{(D + 1)S + S_M}$$

- D Sum of character size and parity size (D = 5 to 10-bit)
- S Samples per bit. S = 16 for Normal Speed mode and S = 8 for Double Speed mode.
- S_F First sample number used for majority voting. S_F = 8 for Normal Speed and S_F = 4 for Double Speed mode.
- S_M Middle sample number used for majority voting. S_M = 9 for Normal Speed and S_M = 5 for Double Speed mode.

R_{slow} is the ratio of the slowest incoming data rate that can be accepted in relation to the receiver baud rate. R_{fast} is the ratio of the fastest incoming data rate that can be accepted in relation to the receiver baud rate.

Table 75 and Table 76 list the maximum receiver baud rate error that can be tolerated. Note that normal speed mode has higher toleration of baud rate variations.

Table 75. Recommended Maximum Receiver Baud Rate Error for Normal Speed Mode (U2X = 0)

| D # (Data+Parity Bit) | R _{slow} % | R _{fast} % | Max Total Error % | Recommended Max Receiver Error % |
|-----------------------|---------------------|---------------------|-------------------|----------------------------------|
| 5 | 93.20 | 106.67 | +6.67/-6.8 | ±3.0 |
| 6 | 94.12 | 105.79 | +5.79/-5.88 | ±2.5 |
| 7 | 94.81 | 105.11 | +5.11/-5.19 | ±2.0 |
| 8 | 95.36 | 104.58 | +4.58/-4.54 | ±2.0 |
| 9 | 95.81 | 104.14 | +4.14/-4.19 | ±1.5 |
| 10 | 96.17 | 103.78 | +3.78/-3.83 | ±1.5 |

Table 76. Recommended Maximum Receiver Baud Rate Error for Double Speed Mode (U2X = 1)

| D # (Data+Parity Bit) | R _{slow} % | R _{fast} % | Max Total Error % | Recommended Max Receiver Error % |
|-----------------------|---------------------|---------------------|-------------------|----------------------------------|
| 5 | 94.12 | 105.66 | +5.66/-5.88 | ±2.5 |
| 6 | 94.92 | 104.92 | +4.92/-5.08 | ±2.0 |
| 7 | 95.52 | 104.35 | +4.35/-4.48 | ±1.5 |
| 8 | 96.00 | 103.90 | +3.90/-4.00 | ±1.5 |
| 9 | 96.39 | 103.53 | +3.53/-3.61 | ±1.5 |
| 10 | 96.70 | 103.23 | +3.23/-3.30 | ±1.0 |

The recommendations of the maximum receiver baud rate error was made under the assumption that the receiver and transmitter equally divides the maximum total error.

There are two possible sources for the receivers baud rate error. The receiver's system clock (XTAL) will always have some minor instability over the supply voltage range and the temperature range. When using a crystal to generate the system clock, this is rarely a problem, but for a resonator the system clock may differ more than 2% depending of the resonators tolerance. The second source for the error is more controllable. The baud rate generator can not always do an exact division of the system frequency to get the baud rate wanted. In this case an UBRR value that gives an acceptable low error can be used if possible.

Multi-processor Communication Mode

Setting the Multi-processor Communication mode (MPCM) bit in UCSRA enables a filtering function of incoming frames received by the USART receiver. Frames that do not contain address information will be ignored and not put into the receive buffer. This effectively reduces the number of incoming frames that has to be handled by the CPU, in a system with multiple MCUs that communicate via the same serial bus. The transmitter is unaffected by the MPCM setting, but has to be used differently when it is a part of a system utilizing the Multi-processor Communication mode.

If the receiver is set up to receive frames that contain 5 to 8 data bits, then the first stop bit indicates if the frame contains data or address information. If the receiver is set up for frames with 9 data bits, then the ninth bit (RXB8) is used for identifying address and data frames. When the frame type bit (the first stop or the 9th bit) is one, the frame contains an address. When the frame type bit is zero the frame is a data frame.

The Multi-processor Communication mode enables several slave MCUs to receive data from a master MCU. This is done by first decoding an address frame to find out which MCU has been addressed. If a particular slave MCU has been addressed, it will receive the following data frames as normal, while the other slave MCUs will ignore the received frames until another address frame is received.

Using MPCM

For an MCU to act as a master MCU, it can use a 9-bit character frame format (UCSZ = 7). The ninth bit (TXB8) must be set when an address frame (TXB8 = 1) or cleared when a data frame (TXB8 = 0) is being transmitted. The slave MCUs must in this case be set to use a 9-bit character frame format.

The following procedure should be used to exchange data in Multi-processor Communication mode:

1. All slave MCUs are in Multi-processor Communication mode (MPCM in UCSRA is set).
2. The master MCU sends an address frame, and all slaves receive and read this frame. In the slave MCUs, the RXC flag in UCSRA will be set as normal.
3. Each slave MCU reads the UDR Register and determines if it has been selected. If so, it clears the MPCM bit in UCSRA, otherwise it waits for the next address byte and keeps the MPCM setting.
4. The addressed MCU will receive all data frames until a new address frame is received. The other slave MCUs, which still have the MPCM bit set, will ignore the data frames.
5. When the last data frame is received by the addressed MCU, the addressed MCU sets the MPCM bit and waits for a new address frame from master. The process then repeats from 2.

Using any of the 5-bit to 8-bit character frame formats is possible, but impractical since the receiver must change between using n and $n+1$ character frame formats. This makes full-duplex operation difficult since the transmitter and receiver uses the same character size setting. If 5-bit to 8-bit character frames are used, the transmitter must be set to use two stop bit (USBS = 1) since the first stop bit is used for indicating the frame type.

Do not use read-modify-write instructions (SBI and CBI) to set or clear the MPCM bit. The MPCM bit shares the same I/O location as the TXC flag and this might accidentally be cleared when using SBI or CBI instructions.

USART Register Description

USARTn I/O Data Register – UDRn

| | | | | | | | | | |
|---------------|-----------|-----|-----|-----|-----|-----|-----|-----|--------------|
| Bit | 7 | 6 | 5 | 4 | 3 | 2 | 1 | 0 | |
| | RXBn[7:0] | | | | | | | | UDRn (Read) |
| | TXBn[7:0] | | | | | | | | UDRn (Write) |
| Read/Write | R/W | R/W | R/W | R/W | R/W | R/W | R/W | R/W | |
| Initial Value | 0 | 0 | 0 | 0 | 0 | 0 | 0 | 0 | |

The USARTn Transmit Data Buffer Register and USARTn Receive Data Buffer Registers share the same I/O address referred to as USARTn Data Register or UDRn. The Transmit Data Buffer Register (TXBn) will be the destination for data written to the UDRn Register location. Reading the UDRn Register location will return the contents of the receive data buffer register (RXBn).

For 5-bit, 6-bit, or 7-bit characters the upper unused bits will be ignored by the Transmitter and set to zero by the Receiver.

The transmit buffer can only be written when the UDREn flag in the UCSRn Register is set. Data written to UDRn when the UDREn flag is not set, will be ignored by the USARTn Transmitter. When data is written to the transmit buffer, and the Transmitter is enabled, the Transmitter will load the data into the Transmit Shift Register when the Shift Register is empty. Then the data will be serially transmitted on the TxDn pin.

The receive buffer consists of a two level FIFO. The FIFO will change its state whenever the receive buffer is accessed. Due to this behavior of the receive buffer, do not use read modify write instructions (SBI and CBI) on this location. Be careful when using bit test instructions (SBIC and SBIS), since these also will change the state of the FIFO.

USART Control and Status Register A – UCSRnA

| | | | | | | | | | |
|---------------|------|------|-------|-----|------|------|------|-------|--------|
| Bit | 7 | 6 | 5 | 4 | 3 | 2 | 1 | 0 | |
| | RXCn | TXCn | UDREn | FEn | DORn | UPEn | U2Xn | MPCMn | UCSRnA |
| Read/Write | R | R/W | R | R | R | R | R/W | R/W | |
| Initial Value | 0 | 0 | 1 | 0 | 0 | 0 | 0 | 0 | |

- **Bit 7 – RXCn: USART Receive Complete**

This flag bit is set when there are unread data in the receive buffer and cleared when the receive buffer is empty (i.e., does not contain any unread data). If the receiver is disabled, the receive buffer will be flushed and consequently the RXCn bit will become zero. The RXCn flag can be used to generate a Receive Complete interrupt (see description of the RXCIEn bit).

- **Bit 6 – TXCn: USART Transmit Complete**

This flag bit is set when the entire frame in the Transmit Shift Register has been shifted out and there are no new data currently present in the transmit buffer (UDRn). The TXCn flag bit is automatically cleared when a transmit complete interrupt is executed, or it can be cleared by writing a one to its bit location. The TXCn flag can generate a Transmit Complete interrupt (see description of the TXCIEn bit).

- **Bit 5 – UDREn: USART Data Register Empty**

The UDREn flag indicates if the transmit buffer (UDRn) is ready to receive new data. If UDREn is one, the buffer is empty, and therefore ready to be written. The UDREn flag can generate a Data Register Empty interrupt (see description of the UDRIEn bit).

UDREn is set after a reset to indicate that the Transmitter is ready.

- **Bit 4 – FEn: Frame Error**



This bit is set if the next character in the receive buffer had a Frame Error when received. I.e. when the first stop bit of the next character in the receive buffer is zero. This bit is valid until the receive buffer (UDRn) is read. The FEn bit is zero when the stop bit of received data is one. Always set this bit to zero when writing to UCSRnA.

- **Bit 3 – DORn: Data OverRun**

This bit is set if a Data OverRun condition is detected. A data overrun occurs when the receive buffer is full (two characters), it is a new character waiting in the Receive Shift Register, and a new start bit is detected. This bit is valid until the receive buffer (UDRn) is read. Always set this bit to zero when writing to UCSRnA.

- **Bit 2 – UPEn: Parity Error**

This bit is set if the next character in the receive buffer had a Parity Error when received and the parity checking was enabled at that point (UPMn1 = 1). This bit is valid until the receive buffer (UDRn) is read. Always set this bit to zero when writing to UCSRnA.

- **Bit 1 – U2Xn: Double the USART Transmission Speed**

This bit only has effect for the asynchronous operation. Write this bit to zero when using synchronous operation.

Writing this bit to one will reduce the divisor of the baud rate divider from 16 to 8 effectively doubling the transfer rate for asynchronous communication.

- **Bit 0 – MPCMn: Multi-Processor Communication Mode**

This bit enables the Multi-processor Communication mode. When the MPCMn bit is written to one, all the incoming frames received by the USART Receiver that do not contain address information will be ignored. The transmitter is unaffected by the MPCMn setting. For more detailed information see [“Multi-processor Communication Mode” on page 186](#).

USARTn Control and Status Register B – UCSRnB

| Bit | 7 | 6 | 5 | 4 | 3 | 2 | 1 | 0 | |
|---------------|--------------------|--------------------|--------------------|-------------------|-------------------|--------------------|-------------------|-------------------|--------------------|
| | RXCIE _n | TXCIE _n | UDRIE _n | RXEN _n | TXEN _n | UCSZ _{n2} | RXB _{8n} | TXB _{8n} | UCSR _{nB} |
| Read/Write | R/W | R/W | R/W | R/W | R/W | R/W | R | R/W | |
| Initial Value | 0 | 0 | 0 | 0 | 0 | 0 | 0 | 0 | |

- **Bit 7 – RXCIE_n: RX Complete Interrupt Enable**

Writing this bit to one enables interrupt on the RXC flag. A USART Receive Complete interrupt will be generated only if the RXCIE bit is written to one, the global interrupt flag in SREG is written to one and the RXC bit in UCSRnA is set.

- **Bit 6 – TXCIE_n: TX Complete Interrupt Enable**

Writing this bit to one enables interrupt on the TXC_n flag. A USART_n Transmit Complete interrupt will be generated only if the TXCIE_n bit is written to one, the global interrupt flag in SREG is written to one and the TXC_n bit in UCSRnA is set.

- **Bit 5 – UDRIE_n: USART Data Register Empty Interrupt Enable**

Writing this bit to one enables interrupt on the UDRE_n flag. A Data Register Empty interrupt will be generated only if the UDRIE_n bit is written to one, the global interrupt flag in SREG is written to one and the UDRE_n bit in UCSRnA is set.

- **Bit 4 – RXEN_n: Receiver Enable**

Writing this bit to one enables the USART_n Receiver. The Receiver will override normal port operation for the Rx_{Dn} pin when enabled. Disabling the Receiver will flush the receive buffer invalidating the FEn, DOR_n and UPE_n flags.

- **Bit 3 – TXEN_n: Transmitter Enable**

Writing this bit to one enables the USARTn Transmitter. The Transmitter will override normal port operation for the TxDn pin when enabled. The disabling of the Transmitter (writing TXENn to zero) will not become effective until ongoing and pending transmissions are completed, i.e., when the Transmit Shift Register and transmit buffer register do not contain data to be transmitted. When disabled, the transmitter will no longer override the TxDn port.

- **Bit 2 – UCSZn2: Character Size**

The UCSZn2 bits combined with the UCSZn1:0 bit in UCSRnC sets the number of data bits (character size) in a frame the Receiver and Transmitter use.

- **Bit 1 – RXB8n: Receive Data Bit 8**

RXB8n is the ninth data bit of the received character when operating with serial frames with 9-data bits. Must be read before reading the low bits from UDRn.

- **Bit 0 – TXB8n: Transmit Data Bit 8**

TXB8n is the 9th data bit in the character to be transmitted when operating with serial frames with 9 data bits. Must be written before writing the low bits to UDRn.

USART Control and Status Register C – UCSRnC

| | | | | | | | | | |
|---------------|-----|--------|-------|-------|-------|--------|--------|--------|--------|
| Bit | 7 | 6 | 5 | 4 | 3 | 2 | 1 | 0 | |
| | – | UMSELn | UPMn1 | UPMn0 | USBSn | UCSZn1 | UCSZn0 | UCPOLn | UCSRnC |
| Read/Write | R/W | R/W | R/W | R/W | R/W | R/W | R/W | R/W | |
| Initial Value | 0 | 0 | 0 | 0 | 0 | 1 | 1 | 0 | |

Note that this register is not available in ATmega103 compatibility mode.

- **Bit 7 – Reserved Bit**

This bit is reserved for future use. For compatibility with future devices, these bit must be written to zero when UCSRnC is written.

- **Bit 6 – UMSELn: USART Mode Select**

This bit selects between Asynchronous and Synchronous mode of operation.

Table 77. UMSELn Bit Settings

| UMSELn | Mode |
|--------|------------------------|
| 0 | Asynchronous Operation |
| 1 | Synchronous Operation |

- **Bit 5:4 – UPMn1:0: Parity Mode**

These bits enable and set type of parity generation and check. If enabled, the Transmitter will automatically generate and send the parity of the transmitted data bits within each frame. The Receiver will generate a parity value for the incoming data and compare it to the UPMn0 setting. If a mismatch is detected, the UPEn flag in UCSRnA will be set.

Table 78. UPMn Bits Settings

| UPMn1 | UPMn0 | Parity Mode |
|-------|-------|----------------------|
| 0 | 0 | Disabled |
| 0 | 1 | (Reserved) |
| 1 | 0 | Enabled, Even Parity |
| 1 | 1 | Enabled, Odd Parity |

- **Bit 3 – USBSn: Stop Bit Select**

This bit selects the number of stop bits to be inserted by the Transmitter. The Receiver ignores this setting.

Table 79. USBSn Bit Settings

| USBSn | Stop Bit(s) |
|-------|-------------|
| 0 | 1-bit |
| 1 | 2-bits |

- **Bit 2:1 – UCSZn1:0: Character Size**

The UCSZn1:0 bits combined with the UCSZn2 bit in UCSRnB sets the number of data bits (character size) in a frame the Receiver and Transmitter use.

Table 80. UCSZn Bits Settings

| UCSZn2 | UCSZn1 | UCSZn0 | Character Size |
|--------|--------|--------|----------------|
| 0 | 0 | 0 | 5-bit |
| 0 | 0 | 1 | 6-bit |
| 0 | 1 | 0 | 7-bit |
| 0 | 1 | 1 | 8-bit |
| 1 | 0 | 0 | Reserved |
| 1 | 0 | 1 | Reserved |
| 1 | 1 | 0 | Reserved |
| 1 | 1 | 1 | 9-bit |

- **Bit 0 – UCPOLn: Clock Polarity**

This bit is used for synchronous mode only. Write this bit to zero when Asynchronous mode is used. The UCPOLn bit sets the relationship between data output change and data input sample, and the synchronous clock (XCKn).

Table 81. UCPOLn Bit Settings

| UCPOLn | Transmitted Data Changed (Output of TxDn Pin) | Received Data Sampled (Input on RxDn Pin) |
|--------|---|---|
| 0 | Rising XCKn Edge | Falling XCKn Edge |
| 1 | Falling XCKn Edge | Rising XCKn Edge |

USART Baud Rate Registers – UBRRnL and UBRRnH

| Bit | 15 | 14 | 13 | 12 | 11 | 10 | 9 | 8 | |
|---------------|------------|----|----|----|-------------|-----|-----|-----|--------|
| | - | - | - | - | UBRRn[11:8] | | | | UBRRnH |
| | UBRRn[7:0] | | | | | | | | UBRRnL |
| Read/Write | R | R | R | R | R/W | R/W | R/W | R/W | |
| Initial Value | 0 | 0 | 0 | 0 | 0 | 0 | 0 | 0 | |
| | 0 | 0 | 0 | 0 | 0 | 0 | 0 | 0 | |

UBRRnH is not available in mega103 compatibility mode

- **Bit 15:12 – Reserved Bits**

These bits are reserved for future use. For compatibility with future devices, these bit must be written to zero when UBRRnH is written.

- **Bit 11:0 – UBRRn11:0: USARTn Baud Rate Register**

This is a 12-bit register which contains the USARTn baud rate. The UBRRnH contains the four most significant bits, and the UBRRnL contains the eight least significant bits of the USARTn baud rate. Ongoing transmissions by the transmitter and receiver will be corrupted if the baud rate is changed. Writing UBRRnL will trigger an immediate update of the baud rate prescaler.

Examples of Baud Rate Setting

For standard crystal and resonator frequencies, the most commonly used baud rates for asynchronous operation can be generated by using the UBRR settings in [Table 82](#). UBRR values which yield an actual baud rate differing less than 0.5% from the target baud rate, are bold in the table. Higher error ratings are acceptable, but the receiver will have less noise resistance when the error ratings are high, especially for large serial frames (see [“Asynchronous Operational Range” on page 185](#)). The error values are calculated using the following equation:

$$\text{Error}[\%] = \left(\frac{\text{BaudRate}_{\text{Closest Match}}}{\text{BaudRate}} - 1 \right) \cdot 100\%$$

Table 82. Examples of UBRR Settings for Commonly Used Oscillator Frequencies

| Baud Rate (bps) | $f_{\text{osc}} = 1.0000\text{MHz}$ | | | | $f_{\text{osc}} = 1.8432\text{MHz}$ | | | | $f_{\text{osc}} = 2.0000\text{MHz}$ | | | |
|--------------------|-------------------------------------|--------|---------|--------|-------------------------------------|--------|-----------|-------|-------------------------------------|--------|---------|-------|
| | U2X = 0 | | U2X = 1 | | U2X = 0 | | U2X = 1 | | U2X = 0 | | U2X = 1 | |
| | UBRR | Error | UBRR | Error | UBRR | Error | UBRR | Error | UBRR | Error | UBRR | Error |
| 2400 | 25 | 0.2% | 51 | 0.2% | 47 | 0.0% | 95 | 0.0% | 51 | 0.2% | 103 | 0.2% |
| 4800 | 12 | 0.2% | 25 | 0.2% | 23 | 0.0% | 47 | 0.0% | 25 | 0.2% | 51 | 0.2% |
| 9600 | 6 | -7.0% | 12 | 0.2% | 11 | 0.0% | 23 | 0.0% | 12 | 0.2% | 25 | 0.2% |
| 14.4k | 3 | 8.5% | 8 | -3.5% | 7 | 0.0% | 15 | 0.0% | 8 | -3.5% | 16 | 2.1% |
| 19.2k | 2 | 8.5% | 6 | -7.0% | 5 | 0.0% | 11 | 0.0% | 6 | -7.0% | 12 | 0.2% |
| 28.8k | 1 | 8.5% | 3 | 8.5% | 3 | 0.0% | 7 | 0.0% | 3 | 8.5% | 8 | -3.5% |
| 38.4k | 1 | -18.6% | 2 | 8.5% | 2 | 0.0% | 5 | 0.0% | 2 | 8.5% | 6 | -7.0% |
| 57.6k | 0 | 8.5% | 1 | 8.5% | 1 | 0.0% | 3 | 0.0% | 1 | 8.5% | 3 | 8.5% |
| 76.8k | – | – | 1 | -18.6% | 1 | -25.0% | 2 | 0.0% | 1 | -18.6% | 2 | 8.5% |
| 115.2k | – | – | 0 | 8.5% | 0 | 0.0% | 1 | 0.0% | 0 | 8.5% | 1 | 8.5% |
| 230.4k | – | – | – | – | – | – | 0 | 0.0% | – | – | – | – |
| 250k | – | – | – | – | – | – | – | – | – | – | 0 | 0.0% |
| Max ⁽¹⁾ | 62.5Kbps | | 125Kbps | | 115.2Kbps | | 230.4Kbps | | 125Kbps | | 250Kbps | |

1. UBRR = 0, Error = 0.0%

Table 83. Examples of UBRR Settings for Commonly Used Oscillator Frequencies

| Baud Rate (bps) | $f_{osc} = 3.6864\text{MHz}$ | | | | $f_{osc} = 4.0000\text{MHz}$ | | | | $f_{osc} = 7.3728\text{MHz}$ | | | |
|--------------------|------------------------------|-------|-----------|-------|------------------------------|-------|---------|-------|------------------------------|-------|-----------|-------|
| | U2X = 0 | | U2X = 1 | | U2X = 0 | | U2X = 1 | | U2X = 0 | | U2X = 1 | |
| | UBRR | Error | UBRR | Error | UBRR | Error | UBRR | Error | UBRR | Error | UBRR | Error |
| 2400 | 95 | 0.0% | 191 | 0.0% | 103 | 0.2% | 207 | 0.2% | 191 | 0.0% | 383 | 0.0% |
| 4800 | 47 | 0.0% | 95 | 0.0% | 51 | 0.2% | 103 | 0.2% | 95 | 0.0% | 191 | 0.0% |
| 9600 | 23 | 0.0% | 47 | 0.0% | 25 | 0.2% | 51 | 0.2% | 47 | 0.0% | 95 | 0.0% |
| 14.4k | 15 | 0.0% | 31 | 0.0% | 16 | 2.1% | 34 | -0.8% | 31 | 0.0% | 63 | 0.0% |
| 19.2k | 11 | 0.0% | 23 | 0.0% | 12 | 0.2% | 25 | 0.2% | 23 | 0.0% | 47 | 0.0% |
| 28.8k | 7 | 0.0% | 15 | 0.0% | 8 | -3.5% | 16 | 2.1% | 15 | 0.0% | 31 | 0.0% |
| 38.4k | 5 | 0.0% | 11 | 0.0% | 6 | -7.0% | 12 | 0.2% | 11 | 0.0% | 23 | 0.0% |
| 57.6k | 3 | 0.0% | 7 | 0.0% | 3 | 8.5% | 8 | -3.5% | 7 | 0.0% | 15 | 0.0% |
| 76.8k | 2 | 0.0% | 5 | 0.0% | 2 | 8.5% | 6 | -7.0% | 5 | 0.0% | 11 | 0.0% |
| 115.2k | 1 | 0.0% | 3 | 0.0% | 1 | 8.5% | 3 | 8.5% | 3 | 0.0% | 7 | 0.0% |
| 230.4k | 0 | 0.0% | 1 | 0.0% | 0 | 8.5% | 1 | 8.5% | 1 | 0.0% | 3 | 0.0% |
| 250k | 0 | -7.8% | 1 | -7.8% | 0 | 0.0% | 1 | 0.0% | 1 | -7.8% | 3 | -7.8% |
| 0.5M | – | – | 0 | -7.8% | – | – | 0 | 0.0% | 0 | -7.8% | 1 | -7.8% |
| 1M | – | – | – | – | – | – | – | – | – | – | 0 | -7.8% |
| Max ⁽¹⁾ | 230.4Kbps | | 460.8Kbps | | 250Kbps | | 0.5Mbps | | 460.8Kbps | | 921.6Kbps | |

1. UBRR = 0, Error = 0.0%

Table 84. Examples of UBRR Settings for Commonly Used Oscillator Frequencies

| Baud Rate (bps) | $f_{osc} = 8.0000\text{MHz}$ | | | | $f_{osc} = 11.0592\text{MHz}$ | | | | $f_{osc} = 14.7456\text{MHz}$ | | | |
|--------------------|------------------------------|-------|---------|-------|-------------------------------|-------|------------|-------|-------------------------------|-------|------------|-------|
| | U2X = 0 | | U2X = 1 | | U2X = 0 | | U2X = 1 | | U2X = 0 | | U2X = 1 | |
| | UBRR | Error | UBRR | Error | UBRR | Error | UBRR | Error | UBRR | Error | UBRR | Error |
| 2400 | 207 | 0.2% | 416 | -0.1% | 287 | 0.0% | 575 | 0.0% | 383 | 0.0% | 767 | 0.0% |
| 4800 | 103 | 0.2% | 207 | 0.2% | 143 | 0.0% | 287 | 0.0% | 191 | 0.0% | 383 | 0.0% |
| 9600 | 51 | 0.2% | 103 | 0.2% | 71 | 0.0% | 143 | 0.0% | 95 | 0.0% | 191 | 0.0% |
| 14.4k | 34 | -0.8% | 68 | 0.6% | 47 | 0.0% | 95 | 0.0% | 63 | 0.0% | 127 | 0.0% |
| 19.2k | 25 | 0.2% | 51 | 0.2% | 35 | 0.0% | 71 | 0.0% | 47 | 0.0% | 95 | 0.0% |
| 28.8k | 16 | 2.1% | 34 | -0.8% | 23 | 0.0% | 47 | 0.0% | 31 | 0.0% | 63 | 0.0% |
| 38.4k | 12 | 0.2% | 25 | 0.2% | 17 | 0.0% | 35 | 0.0% | 23 | 0.0% | 47 | 0.0% |
| 57.6k | 8 | -3.5% | 16 | 2.1% | 11 | 0.0% | 23 | 0.0% | 15 | 0.0% | 31 | 0.0% |
| 76.8k | 6 | -7.0% | 12 | 0.2% | 8 | 0.0% | 17 | 0.0% | 11 | 0.0% | 23 | 0.0% |
| 115.2k | 3 | 8.5% | 8 | -3.5% | 5 | 0.0% | 11 | 0.0% | 7 | 0.0% | 15 | 0.0% |
| 230.4k | 1 | 8.5% | 3 | 8.5% | 2 | 0.0% | 5 | 0.0% | 3 | 0.0% | 7 | 0.0% |
| 250k | 1 | 0.0% | 3 | 0.0% | 2 | -7.8% | 5 | -7.8% | 3 | -7.8% | 6 | 5.3% |
| 0.5M | 0 | 0.0% | 1 | 0.0% | – | – | 2 | -7.8% | 1 | -7.8% | 3 | -7.8% |
| 1M | – | – | 0 | 0.0% | – | – | – | – | 0 | -7.8% | 1 | -7.8% |
| Max ⁽¹⁾ | 0.5Mbps | | 1Mbps | | 691.2Kbps | | 1.3824Mbps | | 921.6Kbps | | 1.8432Mbps | |

1. UBRR = 0, Error = 0.0%

Table 85. Examples of UBRR Settings for Commonly Used Oscillator Frequencies

| Baud Rate (bps) | $f_{osc} = 16.0000\text{MHz}$ | | | |
|--------------------|-------------------------------|-------|---------|-------|
| | U2X = 0 | | U2X = 1 | |
| | UBRR | Error | UBRR | Error |
| 2400 | 416 | -0.1% | 832 | 0.0% |
| 4800 | 207 | 0.2% | 416 | -0.1% |
| 9600 | 103 | 0.2% | 207 | 0.2% |
| 14.4k | 68 | 0.6% | 138 | -0.1% |
| 19.2k | 51 | 0.2% | 103 | 0.2% |
| 28.8k | 34 | -0.8% | 68 | 0.6% |
| 38.4k | 25 | 0.2% | 51 | 0.2% |
| 57.6k | 16 | 2.1% | 34 | -0.8% |
| 76.8k | 12 | 0.2% | 25 | 0.2% |
| 115.2k | 8 | -3.5% | 16 | 2.1% |
| 230.4k | 3 | 8.5% | 8 | -3.5% |
| 250k | 3 | 0.0% | 7 | 0.0% |
| 0.5M | 1 | 0.0% | 3 | 0.0% |
| 1M | 0 | 0.0% | 1 | 0.0% |
| Max ⁽¹⁾ | 1Mbps | | 2Mbps | |

1. UBRR = 0, Error = 0.0%

Two-wire Serial Interface

Features

- Simple yet Powerful and Flexible Communication Interface, only Two Bus Lines Needed
- Both Master and Slave Operation Supported
- Device can Operate as Transmitter or Receiver
- 7-bit Address Space allows up to 128 Different Slave Addresses
- Multi-master Arbitration Support
- Up to 400kHz Data Transfer Speed
- Slew-rate Limited Output Drivers
- Noise Suppression Circuitry Rejects Spikes on Bus Lines
- Fully Programmable Slave Address with General Call Support
- Address Recognition Causes Wake-up when AVR is in Sleep Mode

Two-wire Serial Interface Bus Definition

The Two-wire Serial Interface (TWI) is ideally suited for typical microcontroller applications. The TWI protocol allows the systems designer to interconnect up to 128 different devices using only two bi-directional bus lines, one for clock (SCL) and one for data (SDA). The only external hardware needed to implement the bus is a single pull-up resistor for each of the TWI bus lines. All devices connected to the bus have individual addresses, and mechanisms for resolving bus contention are inherent in the TWI protocol.

Figure 86. TWI Bus Interconnection



TWI Terminology

The following definitions are frequently encountered in this section.

Table 86. TWI Terminology

| Term | Description |
|-------------|--|
| Master | The device that initiates and terminates a transmission. The master also generates the SCL clock |
| Slave | The device addressed by a master |
| Transmitter | The device placing data on the bus |
| Receiver | The device reading data from the bus |

Electrical Interconnection

As depicted in [Figure 86](#), both bus lines are connected to the positive supply voltage through pull-up resistors. The bus drivers of all TWI-compliant devices are open-drain or open-collector. This implements a wired-AND function which is essential to the operation of the interface. A low level on a TWI bus line is generated when one or more TWI devices output a zero. A high level is output when all TWI devices tri-state their outputs, allowing the pull-up resistors to pull the line

high. Note that all AVR devices connected to the TWI bus must be powered in order to allow any bus operation.

The number of devices that can be connected to the bus is only limited by the bus capacitance limit of 400pF and the 7-bit slave address space. A detailed specification of the electrical characteristics of the TWI is given in [“Two-wire Serial Interface Characteristics” on page 322](#). Two different sets of specifications are presented there, one relevant for bus speeds below 100kHz, and one valid for bus speeds up to 400kHz.

Data Transfer and Frame Format

Transferring Bits

Each data bit transferred on the TWI bus is accompanied by a pulse on the clock line. The level of the data line must be stable when the clock line is high. The only exception to this rule is for generating start and stop conditions.

Figure 87. Data Validity



START and STOP Conditions

The master initiates and terminates a data transmission. The transmission is initiated when the master issues a START condition on the bus, and it is terminated when the master issues a STOP condition. Between a START and a STOP condition, the bus is considered busy, and no other master should try to seize control of the bus. A special case occurs when a new START condition is issued between a START and a STOP condition. This is referred to as a REPEATED START condition, and is used when the master wishes to initiate a new transfer without relinquishing control of the bus. After a REPEATED START, the bus is considered busy until the next STOP. This is identical to the START behavior, and therefore START is used to describe both START and REPEATED START for the remainder of this datasheet, unless otherwise noted. As depicted below, START and STOP conditions are signalled by changing the level of the SDA line when the SCL line is high.

Figure 88. START, REPEATED START and STOP Conditions



Address Packet Format

All address packets transmitted on the TWI bus are 9 bits long, consisting of 7 address bits, one READ/WRITE control bit and an acknowledge bit. If the READ/WRITE bit is set, a read operation is to be performed, otherwise a write operation should be performed. When a slave recognizes that it is being addressed, it should acknowledge by pulling SDA low in the ninth SCL (ACK) cycle. If the addressed slave is busy, or for some other reason can not service the master's request, the SDA line should be left high in the ACK clock cycle. The master can then transmit a STOP condition, or a REPEATED START condition to initiate a new transmission. An address packet consisting of a slave address and a READ or a WRITE bit is called SLA+R or SLA+W, respectively.

The MSB of the address byte is transmitted first. Slave addresses can freely be allocated by the designer, but the address 0000 000 is reserved for a general call.

When a general call is issued, all slaves should respond by pulling the SDA line low in the ACK cycle. A general call is used when a master wishes to transmit the same message to several slaves in the system. When the general call address followed by a Write bit is transmitted on the bus, all slaves set up to acknowledge the general call will pull the SDA line low in the ack cycle. The following data packets will then be received by all the slaves that acknowledged the general call. Note that transmitting the general call address followed by a Read bit is meaningless, as this would cause contention if several slaves started transmitting different data.

All addresses of the format 1111 xxx should be reserved for future purposes.

Figure 89. Address Packet Format



Data Packet Format

All data packets transmitted on the TWI bus are 9 bits long, consisting of one data byte and an acknowledge bit. During a data transfer, the master generates the clock and the START and STOP conditions, while the receiver is responsible for acknowledging the reception. An Acknowledge (ACK) is signalled by the receiver pulling the SDA line low during the ninth SCL cycle. If the receiver leaves the SDA line high, a NACK is signalled. When the receiver has received the last byte, or for some reason cannot receive any more bytes, it should inform the transmitter by sending a NACK after the final byte. The MSB of the data byte is transmitted first.

Figure 90. Data Packet Format



Combining Address and Data Packets Into a Transmission

A transmission basically consists of a START condition, a SLA+R/W, one or more data packets and a STOP condition. An empty message, consisting of a START followed by a STOP condition, is illegal. Note that the Wired-ANDing of the SCL line can be used to implement handshaking between the master and the slave. The slave can extend the SCL low period by pulling the SCL line low. This is useful if the clock speed set up by the master is too fast for the slave, or the slave needs extra time for processing between the data transmissions. The slave extending the SCL low period will not affect the SCL high period, which is determined by the master. As a consequence, the slave can reduce the TWI data transfer speed by prolonging the SCL duty cycle.

Figure 91 shows a typical data transmission. Note that several data bytes can be transmitted between the SLA+R/W and the STOP condition, depending on the software protocol implemented by the application software.

Figure 91. Typical Data Transmission



Multi-master Bus Systems, Arbitration and Synchronization

The TWI protocol allows bus systems with several masters. Special concerns have been taken in order to ensure that transmissions will proceed as normal, even if two or more masters initiate a transmission at the same time. Two problems arise in multi-master systems:

- An algorithm must be implemented allowing only one of the masters to complete the transmission. All other masters should cease transmission when they discover that they have lost the selection process. This selection process is called arbitration. When a contending master discovers that it has lost the arbitration process, it should immediately switch to slave mode to check whether it is being addressed by the winning master. The fact that multiple masters have started transmission at the same time should not be detectable to the slaves, i.e., the data being transferred on the bus must not be corrupted.
- Different masters may use different SCL frequencies. A scheme must be devised to synchronize the serial clocks from all masters, in order to let the transmission proceed in a lockstep fashion. This will facilitate the arbitration process.

The wired-ANDing of the bus lines is used to solve both these problems. The serial clocks from all masters will be wired-ANDed, yielding a combined clock with a high period equal to the one from the master with the shortest high period. The low period of the combined clock is equal to the low period of the master with the longest low period. Note that all masters listen to the SCL line, effectively starting to count their SCL high and low time-out periods when the combined SCL line goes high or low, respectively.

Figure 92. SCL Synchronization between Multiple Masters



Arbitration is carried out by all masters continuously monitoring the SDA line after outputting data. If the value read from the SDA line does not match the value the master had output, it has lost the arbitration. Note that a master can only lose arbitration when it outputs a high SDA value while another master outputs a low value. The losing master should immediately go to slave mode, checking if it is being addressed by the winning master. The SDA line should be left high, but losing masters are allowed to generate a clock signal until the end of the current data or address packet. Arbitration will continue until only one master remains, and this may take many bits. If several masters are trying to address the same slave, arbitration will continue into the data packet.

Figure 93. Arbitration Between two Masters

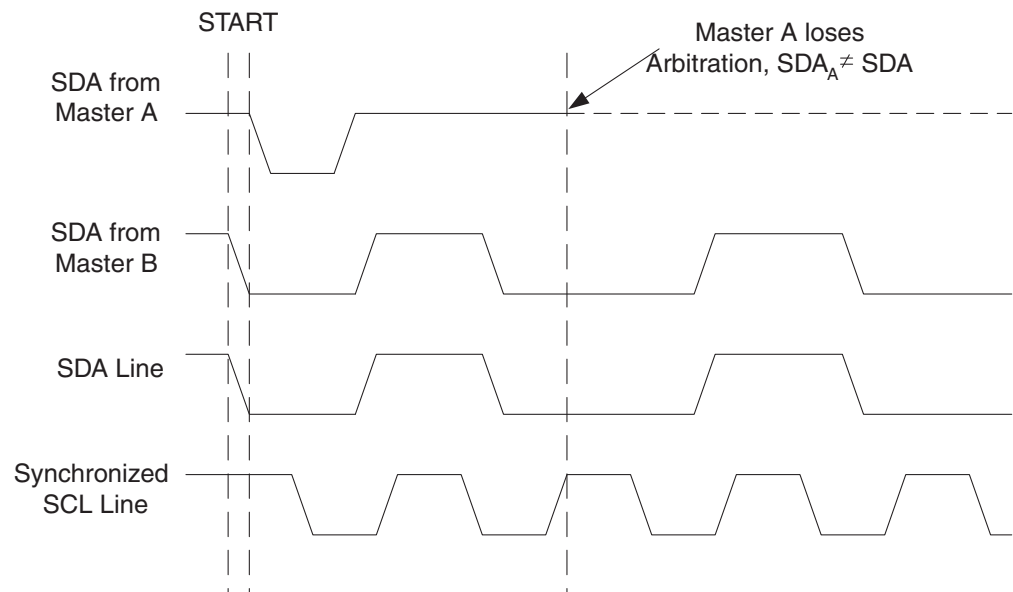

Note that arbitration is not allowed between:

- A REPEATED START condition and a data bit
- A STOP condition and a data bit
- A REPEATED START and a STOP condition

It is the user software's responsibility to ensure that these illegal arbitration conditions never occur. This implies that in multi-master systems, all data transfers must use the same composition of SLA+R/W and data packets. In other words: All transmissions must contain the same number of data packets, otherwise the result of the arbitration is undefined.

Overview of the TWI Module

The TWI module is comprised of several submodules, as shown in Figure 94. All registers drawn in a thick line are accessible through the AVR data bus.

Figure 94. Overview of the TWI Module



Scl and SDA Pins

These pins interface the AVR TWI with the rest of the MCU system. The output drivers contain a slew-rate limiter in order to conform to the TWI specification. The input stages contain a spike suppression unit removing spikes shorter than 50ns. Note that the internal pull-ups in the AVR pads can be enabled by setting the PORT bits corresponding to the SCL and SDA pins, as explained in the I/O Port section. The internal pull-ups can in some systems eliminate the need for external ones.

Bit Rate Generator Unit

This unit controls the period of SCL when operating in a Master mode. The SCL period is controlled by settings in the TWI Bit Rate Register (TWBR) and the Prescaler bits in the TWI Status Register (TWSR). Slave operation does not depend on Bit Rate or Prescaler settings, but the CPU clock frequency in the slave must be at least 16 times higher than the SCL frequency. Note that slaves may prolong the SCL low period, thereby reducing the average TWI bus clock period. The SCL frequency is generated according to the following equation:

$$\text{SCL frequency} = \frac{\text{CPU Clock frequency}}{16 + 2(\text{TWBR}) \cdot 4^{\text{TWPS}}}$$

- TWBR = Value of the TWI Bit Rate Register
- TWPS = Value of the prescaler bits in the TWI Status Register

Note: Pull-up resistor values should be selected according to the SCL frequency and the capacitive bus line load. See Table 133 on page 322 for value of pull-up resistor.

Bus Interface Unit

This unit contains the Data and Address Shift Register (TWDR), a START/STOP Controller and Arbitration detection hardware. The TWDR contains the address or data bytes to be transmitted, or the address or data bytes received. In addition to the 8-bit TWDR, the Bus Interface Unit also contains a register containing the (N)ACK bit to be transmitted or received. This (N)ACK Register is not directly accessible by the application software. However, when receiving, it can be set

or cleared by manipulating the TWI Control Register (TWCR). When in Transmitter mode, the value of the received (N)ACK bit can be determined by the value in the TWSR.

The START/STOP Controller is responsible for generation and detection of START, REPEATED START, and STOP conditions. The START/STOP controller is able to detect START and STOP conditions even when the AVR MCU is in one of the sleep modes, enabling the MCU to wake up if addressed by a master.

If the TWI has initiated a transmission as master, the Arbitration Detection hardware continuously monitors the transmission trying to determine if arbitration is in process. If the TWI has lost an arbitration, the Control Unit is informed. Correct action can then be taken and appropriate status codes generated.

Address Match Unit

The Address Match unit checks if received address bytes match the 7-bit address in the TWI Address Register (TWAR). If the TWI General Call Recognition Enable (TWGCE) bit in the TWAR is written to one, all incoming address bits will also be compared against the General Call address. Upon an address match, the Control Unit is informed, allowing correct action to be taken. The TWI may or may not acknowledge its address, depending on settings in the TWCR. The Address Match unit is able to compare addresses even when the AVR MCU is in sleep mode, enabling the MCU to wake up if addressed by a master. If another interrupt (e.g., INTO) occurs during TWI Power-down address match and wakes up the CPU, the TWI aborts operation and return to its idle state. If this cause any problems, ensure that TWI Address Match is the only enabled interrupt when entering Power-down.

Control Unit

The Control unit monitors the TWI bus and generates responses corresponding to settings in the TWI Control Register (TWCR). When an event requiring the attention of the application occurs on the TWI bus, the TWI Interrupt Flag (TWINT) is asserted. In the next clock cycle, the TWI Status Register (TWSR) is updated with a status code identifying the event. The TWSR only contains relevant status information when the TWI Interrupt Flag is asserted. At all other times, the TWSR contains a special status code indicating that no relevant status information is available. As long as the TWINT flag is set, the SCL line is held low. This allows the application software to complete its tasks before allowing the TWI transmission to continue.

The TWINT flag is set in the following situations:

- After the TWI has transmitted a START/REPEATED START condition
- After the TWI has transmitted SLA+R/W
- After the TWI has transmitted an address byte
- After the TWI has lost arbitration
- After the TWI has been addressed by own slave address or general call
- After the TWI has received a data byte
- After a STOP or REPEATED START has been received while still addressed as a slave
- When a bus error has occurred due to an illegal START or STOP condition

TWI Register Description

TWI Bit Rate Register – TWBR

| | | | | | | | | | |
|---------------|--------------|--------------|--------------|--------------|--------------|--------------|--------------|--------------|------|
| Bit | 7 | 6 | 5 | 4 | 3 | 2 | 1 | 0 | |
| | TWBR7 | TWBR6 | TWBR5 | TWBR4 | TWBR3 | TWBR2 | TWBR1 | TWBR0 | TWBR |
| Read/Write | R/W | R/W | R/W | R/W | R/W | R/W | R/W | R/W | |
| Initial Value | 0 | 0 | 0 | 0 | 0 | 0 | 0 | 0 | |

- **Bits 7..0 – TWI Bit Rate Register**

TWBR selects the division factor for the bit rate generator. The bit rate generator is a frequency divider which generates the SCL clock frequency in the Master modes. See “[Bit Rate Generator Unit](#)” on page 203 for calculating bit rates.

TWI Control Register – TWCR

| | | | | | | | | | |
|---------------|--------------|-------------|--------------|--------------|-------------|-------------|---|-------------|------|
| Bit | 7 | 6 | 5 | 4 | 3 | 2 | 1 | 0 | |
| | TWINT | TWEA | TWSTA | TWSTO | TWWC | TWEN | – | TWIE | TWCR |
| Read/Write | R/W | R/W | R/W | R/W | R | R/W | R | R/W | |
| Initial Value | 0 | 0 | 0 | 0 | 0 | 0 | 0 | 0 | |

The TWCR is used to control the operation of the TWI. It is used to enable the TWI, to initiate a master access by applying a START condition to the bus, to generate a receiver acknowledge, to generate a stop condition, and to control halting of the bus while the data to be written to the bus are written to the TWDR. It also indicates a write collision if data is attempted written to TWDR while the register is inaccessible.

- **Bit 7 – TWINT: TWI Interrupt Flag**

This bit is set by hardware when the TWI has finished its current job and expects application software response. If the I-bit in SREG and TWIE in TWCR are set, the MCU will jump to the TWI interrupt vector. While the TWINT flag is set, the SCL low period is stretched.

The TWINT flag must be cleared by software by writing a logic one to it. Note that this flag is not automatically cleared by hardware when executing the interrupt routine. Also note that clearing this flag starts the operation of the TWI, so all accesses to the TWI Address Register (TWAR), TWI Status Register (TWSR), and TWI Data Register (TWDR) must be complete before clearing this flag.

- **Bit 6 – TWEA: TWI Enable Acknowledge Bit**

The TWEA bit controls the generation of the acknowledge pulse. If the TWEA bit is written to one, the ACK pulse is generated on the TWI bus if the following conditions are met:

1. The device’s own slave address has been received.
2. A general call has been received, while the TWGCE bit in the TWAR is set.
3. A data byte has been received in Master Receiver or Slave Receiver mode.

By writing the TWEA bit to zero, the device can be virtually disconnected from the Two-wire Serial Bus temporarily. Address recognition can then be resumed by writing the TWEA bit to one again.

- **Bit 5 – TWSTA: TWI START Condition Bit**

The application writes the TWSTA bit to one when it desires to become a master on the Two-wire Serial Bus. The TWI hardware checks if the bus is available, and generates a START condition on the bus if it is free. However, if the bus is not free, the TWI waits until a STOP condition is detected, and then generates a new START condition to claim the bus Master status. TWSTA must be cleared by software when the START condition has been transmitted.



- **Bit 4 – TWSTO: TWI STOP Condition Bit**

Writing the TWSTO bit to one in Master mode will generate a STOP condition on the Two-wire Serial Bus. When the STOP condition is executed on the bus, the TWSTO bit is cleared automatically. In slave mode, setting the TWSTO bit can be used to recover from an error condition. This will not generate a STOP condition, but the TWI returns to a well-defined unaddressed Slave mode and releases the SCL and SDA lines to a high impedance state.

- **Bit 3 – TWWC: TWI Write Collision Flag**

The TWWC bit is set when attempting to write to the TWI Data Register – TWDR when TWINT is low. This flag is cleared by writing the TWDR Register when TWINT is high.

- **Bit 2 – TWEN: TWI Enable Bit**

The TWEN bit enables TWI operation and activates the TWI interface. When TWEN is written to one, the TWI takes control over the I/O pins connected to the SCL and SDA pins, enabling the slew-rate limiters and spike filters. If this bit is written to zero, the TWI is switched off and all TWI transmissions are terminated, regardless of any ongoing operation.

- **Bit 1 – Res: Reserved Bit**

This bit is a reserved bit and will always read as zero.

- **Bit 0 – TWIE: TWI Interrupt Enable**

When this bit is written to one, and the I-bit in SREG is set, the TWI interrupt request will be activated for as long as the TWINT flag is high.

TWI Status Register – TWSR

| | | | | | | | | | |
|---------------|---|---|---|---|---|---|-----|-----|------|
| Bit | 7 | 6 | 5 | 4 | 3 | 2 | 1 | 0 | |
| | TWS7 TWS6 TWS5 TWS4 TWS3 – TWPS1 TWPS0 | | | | | | | | TWSR |
| Read/Write | R | R | R | R | R | R | R/W | R/W | |
| Initial Value | 1 | 1 | 1 | 1 | 1 | 0 | 0 | 0 | |

- **Bits 7..3 – TWS: TWI Status**

These 5 bits reflect the status of the TWI logic and the Two-wire Serial Bus. The different status codes are described later in this section. Note that the value read from TWSR contains both the 5-bit status value and the 2-bit prescaler value. The application designer should mask the prescaler bits to zero when checking the Status bits. This makes status checking independent of prescaler setting. This approach is used in this datasheet, unless otherwise noted.

- **Bit 2 – Res: Reserved Bit**

This bit is reserved and will always read as zero.

- **Bits 1..0 – TWPS: TWI Prescaler Bits**

These bits can be read and written, and control the bit rate prescaler.

Table 87. TWI Bit Rate Prescaler

| TWPS1 | TWPS0 | Prescaler Value |
|-------|-------|-----------------|
| 0 | 0 | 1 |
| 0 | 1 | 4 |
| 1 | 0 | 16 |
| 1 | 1 | 64 |

To calculate bit rates, see “[Bit Rate Generator Unit](#)” on page 203. The value of TWPS1..0 is used in the equation.

TWI Data Register – TWDR

| | | | | | | | | | |
|---------------|-------------|-------------|-------------|-------------|-------------|-------------|-------------|-------------|------|
| Bit | 7 | 6 | 5 | 4 | 3 | 2 | 1 | 0 | |
| | TWD7 | TWD6 | TWD5 | TWD4 | TWD3 | TWD2 | TWD1 | TWD0 | TWDR |
| Read/Write | R/W | R/W | R/W | R/W | R/W | R/W | R/W | R/W | |
| Initial Value | 1 | 1 | 1 | 1 | 1 | 1 | 1 | 1 | |

In Transmit mode, TWDR contains the next byte to be transmitted. In receive mode, the TWDR contains the last byte received. It is writable while the TWI is not in the process of shifting a byte. This occurs when the TWI interrupt flag (TWINT) is set by hardware. Note that the Data Register cannot be initialized by the user before the first interrupt occurs. The data in TWDR remains stable as long as TWINT is set. While data is shifted out, data on the bus is simultaneously shifted in. TWDR always contains the last byte present on the bus, except after a wake up from a sleep mode by the TWI interrupt. In this case, the contents of TWDR is undefined. In the case of a lost bus arbitration, no data is lost in the transition from Master to Slave. Handling of the ACK bit is controlled automatically by the TWI logic, the CPU cannot access the ACK bit directly.

- **Bits 7..0 – TWD: TWI Data Register**

These eight bits constitute the next data byte to be transmitted, or the latest data byte received on the Two-wire Serial Bus.

TWI (Slave) Address Register – TWAR

| | | | | | | | | | |
|---------------|-------------|-------------|-------------|-------------|-------------|-------------|-------------|--------------|------|
| Bit | 7 | 6 | 5 | 4 | 3 | 2 | 1 | 0 | |
| | TWA6 | TWA5 | TWA4 | TWA3 | TWA2 | TWA1 | TWA0 | TWGCE | TWAR |
| Read/Write | R/W | R/W | R/W | R/W | R/W | R/W | R/W | R/W | |
| Initial Value | 1 | 1 | 1 | 1 | 1 | 1 | 1 | 0 | |

The TWAR should be loaded with the 7-bit slave address (in the seven most significant bits of TWAR) to which the TWI will respond when programmed as a slave transmitter or receiver, and not needed in the master modes. In multimaster systems, TWAR must be set in masters which can be addressed as slaves by other masters.

The LSB of TWAR is used to enable recognition of the general call address (\$00). There is an associated address comparator that looks for the slave address (or general call address if enabled) in the received serial address. If a match is found, an interrupt request is generated.

- **Bits 7..1 – TWA: TWI (Slave) Address Register**

These seven bits constitute the slave address of the TWI unit.

- **Bit 0 – TWGCE: TWI General Call Recognition Enable Bit**

If set, this bit enables the recognition of a General Call given over the Two-wire Serial Bus.

Using the TWI

The AVR TWI is byte-oriented and interrupt based. Interrupts are issued after all bus events, like reception of a byte or transmission of a START condition. Because the TWI is interrupt-based, the application software is free to carry on other operations during a TWI byte transfer. Note that the TWI Interrupt Enable (TWIE) bit in TWCR together with the Global Interrupt Enable bit in SREG allow the application to decide whether or not assertion of the TWINT flag should generate an interrupt request. If the TWIE bit is cleared, the application must poll the TWINT flag in order to detect actions on the TWI bus.

When the TWINT flag is asserted, the TWI has finished an operation and awaits application response. In this case, the TWI Status Register (TWSR) contains a value indicating the current state of the TWI bus. The application software can then decide how the TWI should behave in the next TWI bus cycle by manipulating the TWCR and TWDR Registers.

Figure 95 is a simple example of how the application can interface to the TWI hardware. In this example, a master wishes to transmit a single data byte to a slave. This description is quite

abstract, a more detailed explanation follows later in this section. A simple code example implementing the desired behavior is also presented.

Figure 95. Interfacing the Application to the TWI in a Typical Transmission



1. The first step in a TWI transmission is to transmit a START condition. This is done by writing a specific value into TWCR, instructing the TWI hardware to transmit a START condition. Which value to write is described later on. However, it is important that the TWINT bit is set in the value written. Writing a one to TWINT clears the flag. The TWI will not start any operation as long as the TWINT bit in TWCR is set. Immediately after the application has cleared TWINT, the TWI will initiate transmission of the START condition.
2. When the START condition has been transmitted, the TWINT flag in TWCR is set, and TWSR is updated with a status code indicating that the START condition has successfully been sent.
3. The application software should now examine the value of TWSR, to make sure that the START condition was successfully transmitted. If TWSR indicates otherwise, the application software might take some special action, like calling an error routine. Assuming that the status code is as expected, the application must load SLA+W into TWDR. Remember that TWDR is used both for address and data. After TWDR has been loaded with the desired SLA+W, a specific value must be written to TWCR, instructing the TWI hardware to transmit the SLA+W present in TWDR. Which value to write is described later on. However, it is important that the TWINT bit is set in the value written. Writing a one to TWINT clears the flag. The TWI will not start any operation as long as the TWINT bit in TWCR is set. Immediately after the application has cleared TWINT, the TWI will initiate transmission of the address packet.
4. When the address packet has been transmitted, the TWINT flag in TWCR is set, and TWSR is updated with a status code indicating that the address packet has successfully been sent. The status code will also reflect whether a slave acknowledged the packet or not.
5. The application software should now examine the value of TWSR, to make sure that the address packet was successfully transmitted, and that the value of the ACK bit was as expected. If TWSR indicates otherwise, the application software might take some special action, like calling an error routine. Assuming that the status code is as expected, the

application must load a data packet into TWDR. Subsequently, a specific value must be written to TWCR, instructing the TWI hardware to transmit the data packet present in TWDR. Which value to write is described later on. However, it is important that the TWINT bit is set in the value written. Writing a one to TWINT clears the flag. The TWI will not start any operation as long as the TWINT bit in TWCR is set. Immediately after the application has cleared TWINT, the TWI will initiate transmission of the data packet.

6. When the data packet has been transmitted, the TWINT flag in TWCR is set, and TWSR is updated with a status code indicating that the data packet has successfully been sent. The status code will also reflect whether a slave acknowledged the packet or not.
7. The application software should now examine the value of TWSR, to make sure that the data packet was successfully transmitted, and that the value of the ACK bit was as expected. If TWSR indicates otherwise, the application software might take some special action, like calling an error routine. Assuming that the status code is as expected, the application must write a specific value to TWCR, instructing the TWI hardware to transmit a STOP condition. Which value to write is described later on. However, it is important that the TWINT bit is set in the value written. Writing a one to TWINT clears the flag. The TWI will not start any operation as long as the TWINT bit in TWCR is set. Immediately after the application has cleared TWINT, the TWI will initiate transmission of the STOP condition. Note that TWINT is NOT set after a STOP condition has been sent.

Even though this example is simple, it shows the principles involved in all TWI transmissions. These can be summarized as follows:

- When the TWI has finished an operation and expects application response, the TWINT flag is set. The SCL line is pulled low until TWINT is cleared.
- When the TWINT flag is set, the user must update all TWI Registers with the value relevant for the next TWI bus cycle. As an example, TWDR must be loaded with the value to be transmitted in the next bus cycle.
- After all TWI Register updates and other pending application software tasks have been completed, TWCR is written. When writing TWCR, the TWINT bit should be set. Writing a one to TWINT clears the flag. The TWI will then commence executing whatever operation was specified by the TWCR setting.

In the following an assembly and C implementation of the example is given. Note that the code below assumes that several definitions have been made for example by using include-files.

| | Assembly Code Example | C Example | Comments |
|---|---|--|--|
| 1 | <pre>ldi r16, (1<<TWINT) (1<<TWSTA) (1<<TWEN) out TWCR, r16</pre> | <pre>TWCR = (1<<TWINT) (1<<TWSTA) (1<<TWEN)</pre> | Send START condition |
| 2 | <pre>wait1: in r16, TWCR sbrs r16, TWINT rjmp wait1</pre> | <pre>while (!(TWCR & (1<<TWINT))) ;</pre> | Wait for TWINT flag set. This indicates that the START condition has been transmitted |
| 3 | <pre>in r16, TWSR andi r16, 0xF8 cpi r16, START brne ERROR</pre> | <pre>if ((TWSR & 0xF8) != START) ERROR();</pre> | Check value of TWI Status Register. Mask prescaler bits. If status different from START go to ERROR |
| | <pre>ldi r16, SLA_W out TWDR, r16 ldi r16, (1<<TWINT) (1<<TWEN) out TWCR, r16</pre> | <pre>TWDR = SLA_W; TWCR = (1<<TWINT) (1<<TWEN);</pre> | Load SLA_W into TWDR Register. Clear TWINT bit in TWCR to start transmission of address |
| 4 | <pre>wait2: in r16, TWCR sbrs r16, TWINT rjmp wait2</pre> | <pre>while (!(TWCR & (1<<TWINT))) ;</pre> | Wait for TWINT flag set. This indicates that the SLA+W has been transmitted, and ACK/NACK has been received. |
| 5 | <pre>in r16, TWSR andi r16, 0xF8 cpi r16, MT_SLA_ACK brne ERROR</pre> | <pre>if ((TWSR & 0xF8) != MT_SLA_ACK) ERROR();</pre> | Check value of TWI Status Register. Mask prescaler bits. If status different from MT_SLA_ACK go to ERROR |
| | <pre>ldi r16, DATA out TWDR, r16 ldi r16, (1<<TWINT) (1<<TWEN) out TWCR, r16</pre> | <pre>TWDR = DATA; TWCR = (1<<TWINT) (1<<TWEN);</pre> | Load DATA into TWDR Register. Clear TWINT bit in TWCR to start transmission of data |
| 6 | <pre>wait3: in r16, TWCR sbrs r16, TWINT rjmp wait3</pre> | <pre>while (!(TWCR & (1<<TWINT))) ;</pre> | Wait for TWINT flag set. This indicates that the DATA has been transmitted, and ACK/NACK has been received. |
| 7 | <pre>in r16, TWSR andi r16, 0xF8 cpi r16, MT_DATA_ACK brne ERROR</pre> | <pre>if ((TWSR & 0xF8) != MT_DATA_ACK) ERROR();</pre> | Check value of TWI Status Register. Mask prescaler bits. If status different from MT_DATA_ACK go to ERROR |
| | <pre>ldi r16, (1<<TWINT) (1<<TWEN) (1<<TWSTO) out TWCR, r16</pre> | <pre>TWCR = (1<<TWINT) (1<<TWEN) (1<<TWSTO);</pre> | Transmit STOP condition |

Note: For I/O registers located in extended I/O map, “IN”, “OUT”, “SBIS”, “SBIC”, “CBI”, and “SBI” instructions must be replaced with instructions that allow access to extended I/O. Typically “LDS” and “STS” combined with “SBR”, “SBRC”, “SBR”, and “CBR”.

Transmission Modes

The TWI can operate in one of four major modes. These are named Master Transmitter (MT), Master Receiver (MR), Slave Transmitter (ST) and Slave Receiver (SR). Several of these modes can be used in the same application. As an example, the TWI can use MT mode to write data into a TWI EEPROM, MR mode to read the data back from the EEPROM. If other masters are present in the system, some of these might transmit data to the TWI, and then SR mode would be used. It is the application software that decides which modes are legal.

The following sections describe each of these modes. Possible status codes are described along with figures detailing data transmission in each of the modes. These figures contain the following abbreviations:

S: START condition

Rs: REPEATED START condition

R: Read bit (high level at SDA)

W: Write bit (low level at SDA)

A: Acknowledge bit (low level at SDA)

\bar{A} : Not acknowledge bit (high level at SDA)

Data: 8-bit data byte

P: STOP condition

SLA: Slave Address

In [Figure 97](#) to [Figure 103](#), circles are used to indicate that the TWINT flag is set. The numbers in the circles show the status code held in TWSR, with the prescaler bits masked to zero. At these points, actions must be taken by the application to continue or complete the TWI transfer. The TWI transfer is suspended until the TWINT flag is cleared by software.

When the TWINT flag is set, the status code in TWSR is used to determine the appropriate software action. For each status code, the required software action and details of the following serial transfer are given in [Table 88](#) to [Table 91](#). Note that the prescaler bits are masked to zero in these tables.

Master Transmitter Mode

In the Master Transmitter mode, a number of data bytes are transmitted to a slave receiver (see [Figure 96](#)). In order to enter a Master mode, a START condition must be transmitted. The format of the following address packet determines whether Master Transmitter or Master Receiver mode is to be entered. If SLA+W is transmitted, MT mode is entered, if SLA+R is transmitted, MR mode is entered. All the status codes mentioned in this section assume that the prescaler bits are zero or are masked to zero.

Figure 96. Data Transfer in Master Transmitter Mode



A START condition is sent by writing the following value to TWCR:

| TWCR | TWINT | TWEA | TWSTA | TWSTO | TWWC | TWEN | - | TWIE |
|-------|-------|------|-------|-------|------|------|---|------|
| value | 1 | X | 1 | 0 | X | 1 | 0 | X |

TWEN must be set to enable the Two-wire Serial Interface, TWSTA must be written to one to transmit a START condition and TWINT must be written to one to clear the TWINT flag. The TWI will then test the Two-wire Serial Bus and generate a START condition as soon as the bus becomes free. After a START condition has been transmitted, the TWINT flag is set by hardware, and the status code in TWSR will be \$08 (See [Table 88](#)). In order to enter MT mode, SLA+W must be transmitted. This is done by writing SLA+W to TWDR. Thereafter the TWINT bit should be cleared (by writing it to one) to continue the transfer. This is accomplished by writing the following value to TWCR:

| TWCR | TWINT | TWEA | TWSTA | TWSTO | TWWC | TWEN | - | TWIE |
|-------|-------|------|-------|-------|------|------|---|------|
| value | 1 | X | 0 | 0 | X | 1 | 0 | X |

When SLA+W have been transmitted and an acknowledgment bit has been received, TWINT is set again and a number of status codes in TWSR are possible. Possible status codes in Master mode are \$18, \$20, or \$38. The appropriate action to be taken for each of these status codes is detailed in [Table 88](#).

When SLA+W has been successfully transmitted, a data packet should be transmitted. This is done by writing the data byte to TWDR. TWDR must only be written when TWINT is high. If not, the access will be discarded, and the Write Collision bit (TWWC) will be set in the TWCR Register. After updating TWDR, the TWINT bit should be cleared (by writing it to one) to continue the transfer. This is accomplished by writing the following value to TWCR:

| TWCR | TWINT | TWEA | TWSTA | TWSTO | TWWC | TWEN | - | TWIE |
|-------|-------|------|-------|-------|------|------|---|------|
| value | 1 | X | 0 | 0 | X | 1 | 0 | X |

This scheme is repeated until the last byte has been sent and the transfer is ended by generating a STOP condition or a repeated START condition. A STOP condition is generated by writing the following value to TWCR:

| TWCR | TWINT | TWEA | TWSTA | TWSTO | TWWC | TWEN | - | TWIE |
|-------|-------|------|-------|-------|------|------|---|------|
| value | 1 | X | 0 | 1 | X | 1 | 0 | X |

A REPEATED START condition is generated by writing the following value to TWCR:

| TWCR | TWINT | TWEA | TWSTA | TWSTO | TWWC | TWEN | - | TWIE |
|-------|-------|------|-------|-------|------|------|---|------|
| value | 1 | X | 1 | 0 | X | 1 | 0 | X |

After a repeated START condition (state \$10) the Two-wire Serial Interface can access the same slave again, or a new slave without transmitting a STOP condition. Repeated START enables the master to switch between slaves, Master Transmitter mode and Master Receiver mode without losing control of the bus.

Table 88. Status Codes for Master Transmitter Mode

| Status Code (TWSR) Prescaler Bits are 0 | Status of the Two-wire Serial Bus and Two-wire Serial Interface Hardware | Application Software Response | | | | | Next Action Taken by TWI Hardware |
|---|--|--|---------|--------|--------|--------|---|
| | | To/from TWDR | To TWCR | | | | |
| | | | STA | STO | TWINT | TWEA | |
| \$08 | A START condition has been transmitted | Load SLA+W | 0 | 0 | 1 | X | SLA+W will be transmitted; ACK or NOT ACK will be received |
| \$10 | A repeated START condition has been transmitted | Load SLA+W or | 0 | 0 | 1 | X | SLA+W will be transmitted; ACK or NOT ACK will be received SLA+R will be transmitted; Logic will switch to master receiver mode |
| | | Load SLA+R | 0 | 0 | 1 | X | |
| \$18 | SLA+W has been transmitted; ACK has been received | Load data byte or | 0 | 0 | 1 | X | Data byte will be transmitted and ACK or NOT ACK will be received Repeated START will be transmitted STOP condition will be transmitted and TWSTO flag will be reset STOP condition followed by a START condition will be transmitted and TWSTO flag will be reset |
| | | No TWDR action or No TWDR action or | 1 0 | 0 1 | 1 1 | X X | |
| | | No TWDR action | 1 | 1 | 1 | X | |
| \$20 | SLA+W has been transmitted; NOT ACK has been received | Load data byte or | 0 | 0 | 1 | X | Data byte will be transmitted and ACK or NOT ACK will be received Repeated START will be transmitted STOP condition will be transmitted and TWSTO flag will be reset STOP condition followed by a START condition will be transmitted and TWSTO flag will be reset |
| | | No TWDR action or No TWDR action or | 1 0 | 0 1 | 1 1 | X X | |
| | | No TWDR action | 1 | 1 | 1 | X | |
| \$28 | Data byte has been transmitted; ACK has been received | Load data byte or | 0 | 0 | 1 | X | Data byte will be transmitted and ACK or NOT ACK will be received Repeated START will be transmitted STOP condition will be transmitted and TWSTO flag will be reset STOP condition followed by a START condition will be transmitted and TWSTO flag will be reset |
| | | No TWDR action or No TWDR action or | 1 0 | 0 1 | 1 1 | X X | |
| | | No TWDR action | 1 | 1 | 1 | X | |
| \$30 | Data byte has been transmitted; NOT ACK has been received | Load data byte or | 0 | 0 | 1 | X | Data byte will be transmitted and ACK or NOT ACK will be received Repeated START will be transmitted STOP condition will be transmitted and TWSTO flag will be reset STOP condition followed by a START condition will be transmitted and TWSTO flag will be reset |
| | | No TWDR action or No TWDR action or | 1 0 | 0 1 | 1 1 | X X | |
| | | No TWDR action | 1 | 1 | 1 | X | |
| \$38 | Arbitration lost in SLA+W or data bytes | No TWDR action or | 0 | 0 | 1 | X | Two-wire Serial Bus will be released and not addressed slave mode entered A START condition will be transmitted when the bus becomes free |
| | | No TWDR action | 1 | 0 | 1 | X | |

Figure 97. Formats and States in the Master Transmitter Mode

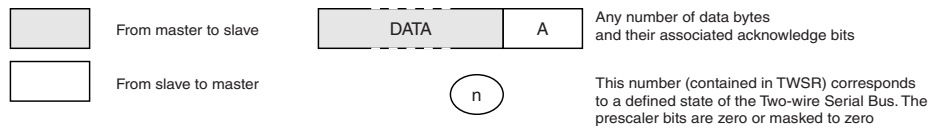
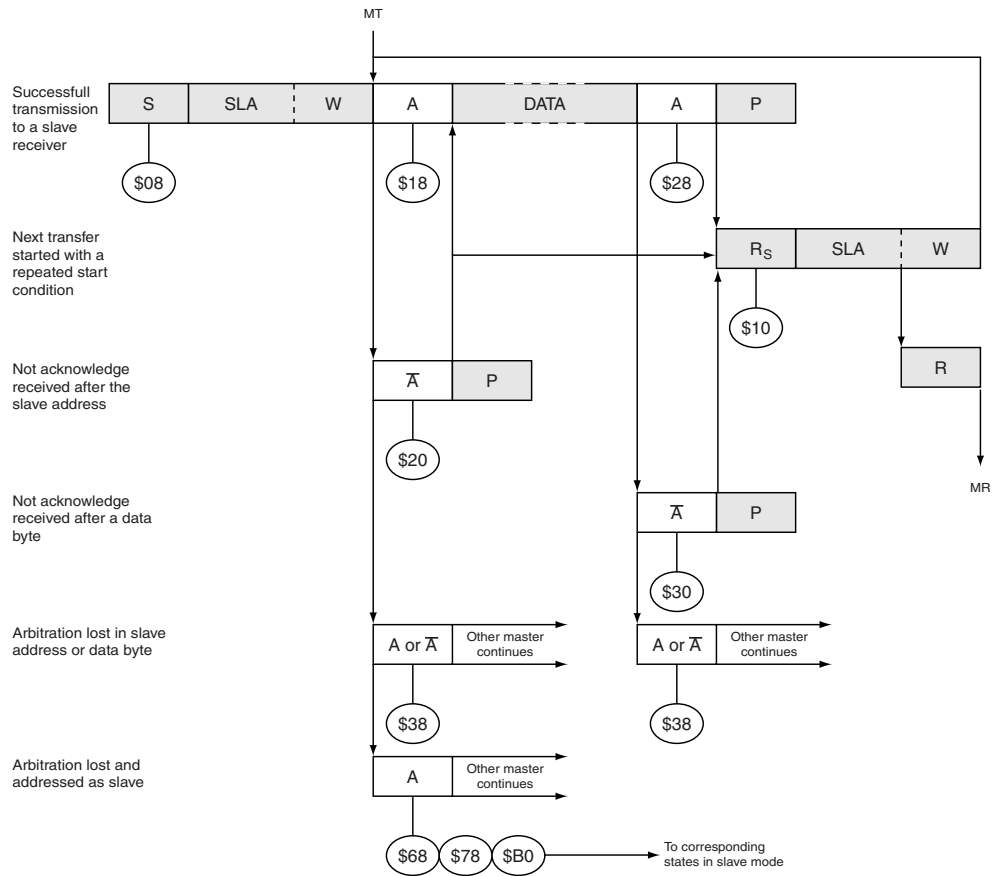

Master Receiver Mode In the Master Receiver Mode, a number of data bytes are received from a slave transmitter (see [Figure 98](#)). In order to enter a Master mode, a START condition must be transmitted. The format of the following address packet determines whether Master Transmitter or Master Receiver mode is to be entered. If SLA+W is transmitted, MT mode is entered, if SLA+R is transmitted, MR mode is entered. All the status codes mentioned in this section assume that the prescaler bits are zero or are masked to zero.

Figure 98. Data Transfer in Master Receiver Mode



A START condition is sent by writing the following value to TWCR:

| TWCR | TWINT | TWEA | TWSTA | TWSTO | TWWC | TWEN | - | TWIE |
|-------|-------|------|-------|-------|------|------|---|------|
| value | 1 | X | 1 | 0 | X | 1 | 0 | X |

TWEN must be written to one to enable the Two-wire Serial Interface, TWSTA must be written to one to transmit a START condition and TWINT must be set to clear the TWINT flag. The TWI will then test the Two-wire Serial Bus and generate a START condition as soon as the bus becomes free. After a START condition has been transmitted, the TWINT flag is set by hardware, and the status code in TWSR will be \$08 (See [Table 88](#)). In order to enter MR mode, SLA+R must be transmitted. This is done by writing SLA+R to TWDR. Thereafter the TWINT bit should be cleared (by writing it to one) to continue the transfer. This is accomplished by writing the following value to TWCR:

| TWCR | TWINT | TWEA | TWSTA | TWSTO | TWWC | TWEN | - | TWIE |
|-------|-------|------|-------|-------|------|------|---|------|
| value | 1 | X | 0 | 0 | X | 1 | 0 | X |

When SLA+R have been transmitted and an acknowledgment bit has been received, TWINT is set again and a number of status codes in TWSR are possible. Possible status codes in Master mode are \$38, \$40, or \$48. The appropriate action to be taken for each of these status codes is detailed in [Table 97](#). Received data can be read from the TWDR Register when the TWINT flag is set high by hardware. This scheme is repeated until the last byte has been received. After the last byte has been received, the MR should inform the ST by sending a NACK after the last received data byte. The transfer is ended by generating a STOP condition or a repeated START condition. A STOP condition is generated by writing the following value to TWCR:

| TWCR | TWINT | TWEA | TWSTA | TWSTO | TWWC | TWEN | - | TWIE |
|-------|-------|------|-------|-------|------|------|---|------|
| value | 1 | X | 0 | 1 | X | 1 | 0 | X |

A REPEATED START condition is generated by writing the following value to TWCR:

| TWCR | TWINT | TWEA | TWSTA | TWSTO | TWWC | TWEN | - | TWIE |
|-------|-------|------|-------|-------|------|------|---|------|
| value | 1 | X | 1 | 0 | X | 1 | 0 | X |

After a repeated START condition (state \$10) the Two-wire Serial Interface can access the same slave again, or a new slave without transmitting a STOP condition. Repeated START

enables the master to switch between slaves, Master Transmitter mode and Master Receiver mode without losing control over the bus.

Figure 99. Formats and States in the Master Receiver Mode



Table 89. Status Codes for Master Receiver Mode

| Status Code (TWSR) Prescaler Bits are 0 | Status of the Two-wire Serial Bus and Two-wire Serial Interface Hardware | Application Software Response | | | | | Next Action Taken by TWI Hardware |
|---|--|-------------------------------|---------|-----|-------|------|--|
| | | To/from TWDR | To TWCR | | | | |
| | | | STA | STO | TWINT | TWEA | |
| \$08 | A START condition has been transmitted | Load SLA+R | 0 | 0 | 1 | X | SLA+R will be transmitted ACK or NOT ACK will be received |
| \$10 | A repeated START condition has been transmitted | Load SLA+R or | 0 | 0 | 1 | X | SLA+R will be transmitted ACK or NOT ACK will be received SLA+W will be transmitted Logic will switch to master transmitter mode |
| | | Load SLA+W | 0 | 0 | 1 | X | |
| \$38 | Arbitration lost in SLA+R or NOT ACK bit | No TWDR action or | 0 | 0 | 1 | X | Two-wire Serial Bus will be released and not addressed slave mode will be entered A START condition will be transmitted when the bus becomes free |
| | | No TWDR action | 1 | 0 | 1 | X | |
| \$40 | SLA+R has been transmitted; ACK has been received | No TWDR action or | 0 | 0 | 1 | 0 | Data byte will be received and NOT ACK will be returned Data byte will be received and ACK will be returned |
| | | No TWDR action | 0 | 0 | 1 | 1 | |
| \$48 | SLA+R has been transmitted; NOT ACK has been received | No TWDR action or | 1 | 0 | 1 | X | Repeated START will be transmitted STOP condition will be transmitted and TWSTO flag will be reset STOP condition followed by a START condition will be transmitted and TWSTO flag will be reset |
| | | No TWDR action or | 0 | 1 | 1 | X | |
| | | No TWDR action | 1 | 1 | 1 | X | |
| \$50 | Data byte has been received; ACK has been returned | Read data byte or | 0 | 0 | 1 | 0 | Data byte will be received and NOT ACK will be returned Data byte will be received and ACK will be returned |
| | | Read data byte | 0 | 0 | 1 | 1 | |
| \$58 | Data byte has been received; NOT ACK has been returned | Read data byte or | 1 | 0 | 1 | X | Repeated START will be transmitted STOP condition will be transmitted and TWSTO flag will be reset STOP condition followed by a START condition will be transmitted and TWSTO flag will be reset |
| | | Read data byte or | 0 | 1 | 1 | X | |
| | | Read data byte | 1 | 1 | 1 | X | |

Slave Receiver Mode

In the Slave Receiver mode, a number of data bytes are received from a master transmitter (see [Figure 100](#)). All the status codes mentioned in this section assume that the prescaler bits are zero or are masked to zero.

Figure 100. Data Transfer in Slave Receiver Mode



To initiate the Slave Receiver mode, TWAR and TWCR must be initialized as follows:

| | | | | | | | | |
|-------------|----------------------------|-------------|-------------|-------------|-------------|-------------|-------------|--------------|
| TWAR | TWA6 | TWA5 | TWA4 | TWA3 | TWA2 | TWA1 | TWA0 | TWGCE |
| value | Device's Own Slave Address | | | | | | | |

The upper seven bits are the address to which the Two-wire Serial Interface will respond when addressed by a master. If the LSB is set, the TWI will respond to the general call address (\$00), otherwise it will ignore the general call address.

| TWCR | TWINT | TWEA | TWSTA | TWSTO | TWWC | TWEN | – | TWIE |
|-------|-------|------|-------|-------|------|------|---|------|
| value | 0 | 1 | 0 | 0 | 0 | 1 | 0 | X |

TWEN must be written to one to enable the TWI. The TWEA bit must be written to one to enable the acknowledgment of the device’s own slave address or the general call address. TWSTA and TWSTO must be written to zero.

When TWAR and TWCR have been initialized, the TWI waits until it is addressed by its own slave address (or the general call address if enabled) followed by the data direction bit. If the direction bit is “0” (write), the TWI will operate in SR mode, otherwise ST mode is entered. After its own slave address and the write bit have been received, the TWINT flag is set and a valid status code can be read from TWSR. The status code is used to determine the appropriate software action. The appropriate action to be taken for each status code is detailed in [Table 90](#). The slave receiver mode may also be entered if arbitration is lost while the TWI is in the master mode (see states \$68 and \$78).

If the TWEA bit is reset during a transfer, the TWI will return a “Not Acknowledge” (“1”) to SDA after the next received data byte. This can be used to indicate that the slave is not able to receive any more bytes. While TWEA is zero, the TWI does not acknowledge its own slave address. However, the Two-wire Serial Bus is still monitored and address recognition may resume at any time by setting TWEA. This implies that the TWEA bit may be used to temporarily isolate the TWI from the Two-wire Serial Bus.

In all sleep modes other than Idle mode, the clock system to the TWI is turned off. If the TWEA bit is set, the interface can still acknowledge its own slave address or the general call address by using the Two-wire Serial Bus clock as a clock source. The part will then wake up from sleep and the TWI will hold the SCL clock low during the wake up and until the TWINT flag is cleared (by writing it to one). Further data reception will be carried out as normal, with the AVR clocks running as normal. Observe that if the AVR is set up with a long start-up time, the SCL line may be held low for a long time, blocking other data transmissions.

Note that the Two-wire Serial Interface Data Register – TWDR does not reflect the last byte present on the bus when waking up from these sleep modes.

Table 90. Status Codes for Slave Receiver Mode

| Status Code (TWSR) Prescaler Bits are 0 | Status of the Two-wire Serial Bus and Two-wire Serial Interface Hardware | Application Software Response | | | | | Next Action Taken by TWI Hardware |
|---|--|-------------------------------|---------|-----|-------|------|--|
| | | To/from TWDR | To TWCR | | | | |
| | | | STA | STO | TWINT | TWEA | |
| \$60 | Own SLA+W has been received; ACK has been returned | No TWDR action or | X | 0 | 1 | 0 | Data byte will be received and NOT ACK will be returned |
| | | No TWDR action | X | 0 | 1 | 1 | Data byte will be received and ACK will be returned |
| \$68 | Arbitration lost in SLA+R/W as master; own SLA+W has been received; ACK has been returned | No TWDR action or | X | 0 | 1 | 0 | Data byte will be received and NOT ACK will be returned |
| | | No TWDR action | X | 0 | 1 | 1 | Data byte will be received and ACK will be returned |
| \$70 | General call address has been received; ACK has been returned | No TWDR action or | X | 0 | 1 | 0 | Data byte will be received and NOT ACK will be returned |
| | | No TWDR action | X | 0 | 1 | 1 | Data byte will be received and ACK will be returned |
| \$78 | Arbitration lost in SLA+R/W as master; General call address has been received; ACK has been returned | No TWDR action or | X | 0 | 1 | 0 | Data byte will be received and NOT ACK will be returned |
| | | No TWDR action | X | 0 | 1 | 1 | Data byte will be received and ACK will be returned |
| \$80 | Previously addressed with own SLA+W; data has been received; ACK has been returned | Read data byte or | X | 0 | 1 | 0 | Data byte will be received and NOT ACK will be returned |
| | | Read data byte | X | 0 | 1 | 1 | Data byte will be received and ACK will be returned |
| \$88 | Previously addressed with own SLA+W; data has been received; NOT ACK has been returned | Read data byte or | 0 | 0 | 1 | 0 | Switched to the not addressed slave mode; no recognition of own SLA or GCA |
| | | Read data byte or | 0 | 0 | 1 | 1 | Switched to the not addressed slave mode; own SLA will be recognized; GCA will be recognized if TWGCE = "1" |
| | | Read data byte or | 1 | 0 | 1 | 0 | Switched to the not addressed slave mode; no recognition of own SLA or GCA; a START condition will be transmitted when the bus becomes free |
| | | Read data byte | 1 | 0 | 1 | 1 | Switched to the not addressed slave mode; own SLA will be recognized; GCA will be recognized if TWGCE = "1"; a START condition will be transmitted when the bus becomes free |
| \$90 | Previously addressed with general call; data has been received; ACK has been returned | Read data byte or | X | 0 | 1 | 0 | Data byte will be received and NOT ACK will be returned |
| | | Read data byte | X | 0 | 1 | 1 | Data byte will be received and ACK will be returned |
| \$98 | Previously addressed with general call; data has been received; NOT ACK has been returned | Read data byte or | 0 | 0 | 1 | 0 | Switched to the not addressed slave mode; no recognition of own SLA or GCA |
| | | Read data byte or | 0 | 0 | 1 | 1 | Switched to the not addressed slave mode; own SLA will be recognized; GCA will be recognized if TWGCE = "1" |
| | | Read data byte or | 1 | 0 | 1 | 0 | Switched to the not addressed slave mode; no recognition of own SLA or GCA; a START condition will be transmitted when the bus becomes free |
| | | Read data byte | 1 | 0 | 1 | 1 | Switched to the not addressed slave mode; own SLA will be recognized; GCA will be recognized if TWGCE = "1"; a START condition will be transmitted when the bus becomes free |
| \$A0 | A STOP condition or repeated START condition has been received while still addressed as slave | No Action | 0 | 0 | 1 | 0 | Switched to the not addressed slave mode; no recognition of own SLA or GCA |
| | | | 0 | 0 | 1 | 1 | Switched to the not addressed slave mode; own SLA will be recognized; GCA will be recognized if TWGCE = "1" |
| | | | 1 | 0 | 1 | 0 | Switched to the not addressed slave mode; no recognition of own SLA or GCA; a START condition will be transmitted when the bus becomes free |
| | | | 1 | 0 | 1 | 1 | Switched to the not addressed slave mode; own SLA will be recognized; GCA will be recognized if TWGCE = "1"; a START condition will be transmitted when the bus becomes free |

Figure 101. Formats and States in the Slave Receiver Mode

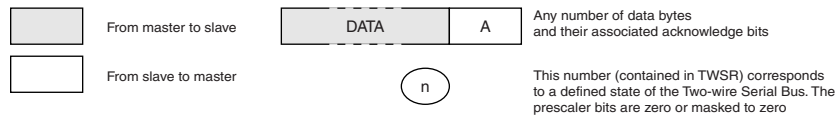

Slave Transmitter Mode

In the Slave Transmitter mode, a number of data bytes are transmitted to a master receiver (see [Figure 102](#)). All the status codes mentioned in this section assume that the prescaler bits are zero or are masked to zero.

Figure 102. Data Transfer in Slave Transmitter Mode

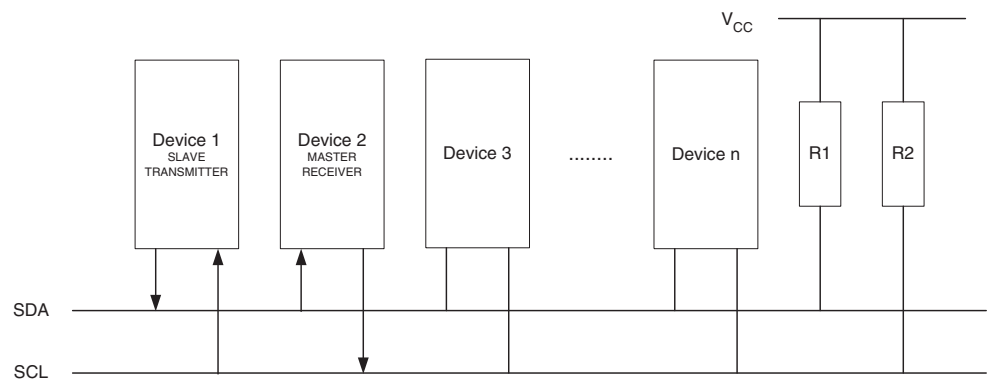

To initiate the Slave Transmitter mode, TWAR and TWCR must be initialized as follows:

| TWAR | TWA6 | TWA5 | TWA4 | TWA3 | TWA2 | TWA1 | TWA0 | TWGCE |
|-------|----------------------------|------|------|------|------|------|------|-------|
| value | Device's Own Slave Address | | | | | | | |

The upper seven bits are the address to which the Two-wire Serial Interface will respond when addressed by a master. If the LSB is set, the TWI will respond to the general call address (\$00), otherwise it will ignore the general call address.

| TWCR | TWINT | TWEA | TWSTA | TWSTO | TWWC | TWEN | – | TWIE |
|-------|-------|------|-------|-------|------|------|---|------|
| value | 0 | 1 | 0 | 0 | 0 | 1 | 0 | X |

TWEN must be written to one to enable the TWI. The TWEA bit must be written to one to enable the acknowledgment of the device's own slave address or the general call address. TWSTA and TWSTO must be written to zero.

When TWAR and TWCR have been initialized, the TWI waits until it is addressed by its own slave address (or the general call address if enabled) followed by the data direction bit. If the direction bit is "1" (read), the TWI will operate in ST mode, otherwise SR mode is entered. After its own slave address and the write bit have been received, the TWINT flag is set and a valid status code can be read from TWSR. The status code is used to determine the appropriate software action. The appropriate action to be taken for each status code is detailed in [Table 91](#). The Slave Transmitter mode may also be entered if arbitration is lost while the TWI is in the Master mode (see state \$B0).

If the TWEA bit is written to zero during a transfer, the TWI will transmit the last byte of the transfer. State \$C0 or state \$C8 will be entered, depending on whether the master receiver transmits a NACK or ACK after the final byte. The TWI is switched to the not addressed slave mode, and will ignore the master if it continues the transfer. Thus the master receiver receives all "1" as serial data. State \$C8 is entered if the master demands additional data bytes (by transmitting ACK), even though the slave has transmitted the last byte (TWEA zero and expecting NACK from the master).

While TWEA is zero, the TWI does not respond to its own slave address. However, the Two-wire Serial Bus is still monitored and address recognition may resume at any time by setting TWEA. This implies that the TWEA bit may be used to temporarily isolate the TWI from the Two-wire Serial Bus.

In all sleep modes other than Idle mode, the clock system to the TWI is turned off. If the TWEA bit is set, the interface can still acknowledge its own slave address or the general call address by using the Two-wire Serial Bus clock as a clock source. The part will then wake up from sleep and the TWI will hold the SCL clock will low during the wake up and until the TWINT flag is cleared (by writing it to one). Further data transmission will be carried out as normal, with the AVR clocks running as normal. Observe that if the AVR is set up with a long start-up time, the SCL line may be held low for a long time, blocking other data transmissions.

Note that the Two-wire Serial Interface Data Register – TWDR does not reflect the last byte present on the bus when waking up from these sleep modes.

Table 91. Status Codes for Slave Transmitter Mode

| Status Code (TWSR) Prescaler Bits are 0 | Status of the Two-wire Serial Bus and Two-wire Serial Interface Hardware | Application Software Response | | | | | Next Action Taken by TWI Hardware |
|---|---|-------------------------------|---------|-----|-------|------|--|
| | | To/from TWDR | To TWCR | | | | |
| | | | STA | STO | TWINT | TWEA | |
| \$A8 | Own SLA+R has been received; ACK has been returned | Load data byte or | X | 0 | 1 | 0 | Last data byte will be transmitted and NOT ACK should be received Data byte will be transmitted and ACK should be received |
| | | Load data byte | X | 0 | 1 | 1 | |
| \$B0 | Arbitration lost in SLA+R/W as master; own SLA+R has been received; ACK has been returned | Load data byte or | X | 0 | 1 | 0 | Last data byte will be transmitted and NOT ACK should be received Data byte will be transmitted and ACK should be received |
| | | Load data byte | X | 0 | 1 | 1 | |
| \$B8 | Data byte in TWDR has been transmitted; ACK has been received | Load data byte or | X | 0 | 1 | 0 | Last data byte will be transmitted and NOT ACK should be received Data byte will be transmitted and ACK should be received |
| | | Load data byte | X | 0 | 1 | 1 | |
| \$C0 | Data byte in TWDR has been transmitted; NOT ACK has been received | No TWDR action or | 0 | 0 | 1 | 0 | Switched to the not addressed slave mode; no recognition of own SLA or GCA Switched to the not addressed slave mode; own SLA will be recognized; GCA will be recognized if TWGCE = "1" Switched to the not addressed slave mode; no recognition of own SLA or GCA; a START condition will be transmitted when the bus becomes free Switched to the not addressed slave mode; own SLA will be recognized; GCA will be recognized if TWGCE = "1"; a START condition will be transmitted when the bus becomes free |
| | | No TWDR action or | 0 | 0 | 1 | 1 | |
| | | No TWDR action or | 1 | 0 | 1 | 0 | |
| | | No TWDR action | 1 | 0 | 1 | 1 | |
| \$C8 | Last data byte in TWDR has been transmitted (TWEA = "0"); ACK has been received | No TWDR action or | 0 | 0 | 1 | 0 | Switched to the not addressed slave mode; no recognition of own SLA or GCA Switched to the not addressed slave mode; own SLA will be recognized; GCA will be recognized if TWGCE = "1" Switched to the not addressed slave mode; no recognition of own SLA or GCA; a START condition will be transmitted when the bus becomes free Switched to the not addressed slave mode; own SLA will be recognized; GCA will be recognized if TWGCE = "1"; a START condition will be transmitted when the bus becomes free |
| | | No TWDR action or | 0 | 0 | 1 | 1 | |
| | | No TWDR action or | 1 | 0 | 1 | 0 | |
| | | No TWDR action | 1 | 0 | 1 | 1 | |

Figure 103. Formats and States in the Slave Transmitter Mode



Miscellaneous States There are two status codes that do not correspond to a defined TWI state, see [Table 92](#).

Status \$F8 indicates that no relevant information is available because the TWINT flag is not set. This occurs between other states, and when the TWI is not involved in a serial transfer.

Status \$00 indicates that a bus error has occurred during a Two-wire Serial Bus transfer. A bus error occurs when a START or STOP condition occurs at an illegal position in the format frame. Examples of such illegal positions are during the serial transfer of an address byte, a data byte, or an acknowledge bit. When a bus error occurs, TWINT is set. To recover from a bus error, the TWSTO flag must set and TWINT must be cleared by writing a logic one to it. This causes the TWI to enter the not addressed slave mode and to clear the TWSTO flag (no other bits in TWCR are affected). The SDA and SCL lines are released, and no STOP condition is transmitted.

Table 92. Miscellaneous States

| Status Code (TWSR) Prescaler Bits are 0 | Status of the Two-wire Serial Bus and Two-wire Serial Interface Hardware | Application Software Response | | | | | Next Action Taken by TWI Hardware |
|---|--|-------------------------------|----------------|-----|-------|------|---|
| | | To/from TWDR | To TWCR | | | | |
| | | | STA | STO | TWINT | TWEA | |
| \$F8 | No relevant state information available; TWINT = "0" | No TWDR action | No TWCR action | | | | Wait or proceed current transfer |
| \$00 | Bus error due to an illegal START or STOP condition | No TWDR action | 0 | 1 | 1 | X | Only the internal hardware is affected, no STOP condition is sent on the bus. In all cases, the bus is released and TWSTO is cleared. |

Combining Several TWI Modes

In some cases, several TWI modes must be combined in order to complete the desired action. Consider for example reading data from a serial EEPROM. Typically, such a transfer involves the following steps:

1. The transfer must be initiated
2. The EEPROM must be instructed what location should be read
3. The reading must be performed
4. The transfer must be finished

Note that data is transmitted both from master to slave and vice versa. The master must instruct the slave what location it wants to read, requiring the use of the MT mode. Subsequently, data must be read from the slave, implying the use of the MR mode. Thus, the transfer direction must be changed. The master must keep control of the bus during all these steps, and the steps should be carried out as an atomical operation. If this principle is violated in a multimaster system, another master can alter the data pointer in the EEPROM between steps 2 and 3, and the master will read the wrong data location. Such a change in transfer direction is accomplished by transmitting a REPEATED START between the transmission of the address byte and reception of the data. After a REPEATED START, the master keeps ownership of the bus. The following figure shows the flow in this transfer.

Figure 104. Combining Several TWI Modes to Access a Serial EEPROM

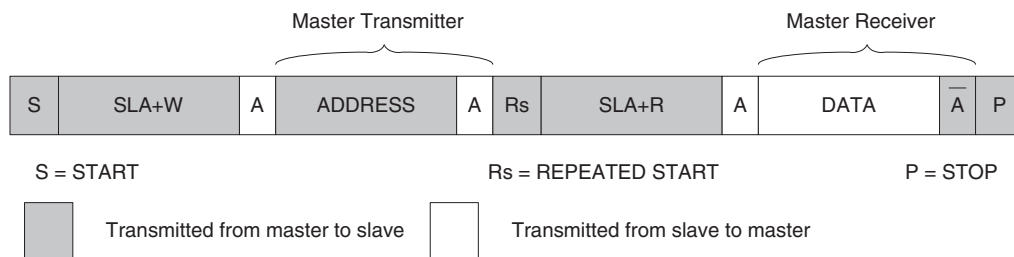

Multi-master Systems and Arbitration

If multiple masters are connected to the same bus, transmissions may be initiated simultaneously by one or more of them. The TWI standard ensures that such situations are handled in such a way that one of the masters will be allowed to proceed with the transfer, and that no data will be lost in the process. An example of an arbitration situation is depicted below, where two masters are trying to transmit data to a slave receiver.

Figure 105. An Arbitration Example



Several different scenarios may arise during arbitration, as described below:

- Two or more masters are performing identical communication with the same slave. In this case, neither the slave nor any of the masters will know about the bus contention.
- Two or more masters are accessing the same slave with different data or direction bit. In this case, arbitration will occur, either in the READ/WRITE bit or in the data bits. The masters trying to output a one on SDA while another master outputs a zero will lose the arbitration. Losing masters will switch to not addressed slave mode or wait until the bus is free and transmit a new START condition, depending on application software action.
- Two or more masters are accessing different slaves. In this case, arbitration will occur in the SLA bits. Masters trying to output a one on SDA while another master outputs a zero will lose the arbitration. Masters losing arbitration in SLA will switch to slave mode to check if they are being addressed by the winning master. If addressed, they will switch to SR or ST mode, depending on the value of the READ/WRITE bit. If they are not being addressed, they will switch to not addressed slave mode or wait until the bus is free and transmit a new START condition, depending on application software action.

This is summarized in [Figure 106](#). Possible status values are given in circles.

Figure 106. Possible Status Codes Caused by Arbitration



Analog Comparator

The Analog Comparator compares the input values on the positive pin AIN0 and negative pin AIN1. When the voltage on the positive pin AIN0 is higher than the voltage on the negative pin AIN1, the Analog Comparator Output, ACO, is set. The comparator's output can be set to trigger the Timer/Counter1 Input Capture function. In addition, the comparator can trigger a separate interrupt, exclusive to the Analog Comparator. The user can select Interrupt triggering on comparator output rise, fall or toggle. A block diagram of the comparator and its surrounding logic is shown in Figure 107.

Figure 107. Analog Comparator Block Diagram



- Notes:
1. See [Table 94 on page 229](#).
 2. Refer to [Figure 1 on page 2](#) and [Table 39 on page 80](#) for Analog Comparator pin placement.

Special Function IO Register – SFIOR

| Bit | 7 | 6 | 5 | 4 | 3 | 2 | 1 | 0 | |
|---------------|-----|---|---|---|------|-----|------|--------|-------|
| | TSM | - | - | - | ACME | PUD | PSR0 | PSR321 | SFIOR |
| Read/Write | R/W | R | R | R | R/W | R/W | R/W | R/W | |
| Initial Value | 0 | 0 | 0 | 0 | 0 | 0 | 0 | 0 | |

• Bit 3 – ACME: Analog Comparator Multiplexer Enable

When this bit is written logic one and the ADC is switched off (ADEN in ADCSRA is zero), the ADC multiplexer selects the negative input to the Analog Comparator. When this bit is written logic zero, AIN1 is applied to the negative input of the Analog Comparator. For a detailed description of this bit, see [“Analog Comparator Multiplexed Input” on page 228](#).

Analog Comparator Control and Status Register – ACSR

| Bit | 7 | 6 | 5 | 4 | 3 | 2 | 1 | 0 | |
|---------------|-----|------|-----|-----|------|------|-------|-------|------|
| | ACD | ACBG | ACO | ACI | ACIE | ACIC | ACIS1 | ACIS0 | ACSR |
| Read/Write | R/W | R/W | R | R/W | R/W | R/W | R/W | R/W | |
| Initial Value | 0 | 0 | N/A | 0 | 0 | 0 | 0 | 0 | |

• Bit 7 – ACD: Analog Comparator Disable

When this bit is written logic one, the power to the Analog Comparator is switched off. This bit can be set at any time to turn off the Analog Comparator. This will reduce power consumption in Active and Idle mode. When changing the ACD bit, the Analog Comparator Interrupt must be

disabled by clearing the ACIE bit in ACSR. Otherwise an interrupt can occur when the bit is changed.

- **Bit 6 – ACBG: Analog Comparator Bandgap Select**

When this bit is set, a fixed bandgap reference voltage replaces the positive input to the Analog Comparator. When this bit is cleared, AIN0 is applied to the positive input of the Analog Comparator. See “Internal Voltage Reference” on page 53.

- **Bit 5 – ACO: Analog Comparator Output**

The output of the Analog Comparator is synchronized and then directly connected to ACO. The synchronization introduces a delay of 1 – 2 clock cycles.

- **Bit 4 – ACI: Analog Comparator Interrupt Flag**

This bit is set by hardware when a comparator output event triggers the interrupt mode defined by ACIS1 and ACIS0. The Analog Comparator Interrupt routine is executed if the ACIE bit is set and the I-bit in SREG is set. ACI is cleared by hardware when executing the corresponding interrupt handling vector. Alternatively, ACI is cleared by writing a logic one to the flag.

- **Bit 3 – ACIE: Analog Comparator Interrupt Enable**

When the ACIE bit is written logic one and the I-bit in the Status Register is set, the Analog Comparator interrupt is activated. When written logic zero, the interrupt is disabled.

- **Bit 2 – ACIC: Analog Comparator Input Capture Enable**

When written logic one, this bit enables the Input Capture function in Timer/Counter1 to be triggered by the Analog Comparator. The comparator output is in this case directly connected to the Input Capture front-end logic, making the comparator utilize the noise canceler and edge select features of the Timer/Counter1 Input Capture interrupt. When written logic zero, no connection between the analog comparator and the Input Capture function exists. To make the comparator trigger the Timer/Counter1 Input Capture interrupt, the TICIE1 bit in the Timer Interrupt Mask Register (TIMSK) must be set.

- **Bits 1, 0 – ACIS1, ACIS0: Analog Comparator Interrupt Mode Select**

These bits determine which comparator events that trigger the Analog Comparator interrupt. The different settings are shown in Table 93.

Table 93. ACIS1/ACIS0 Settings

| ACIS1 | ACIS0 | Interrupt Mode |
|-------|-------|---|
| 0 | 0 | Comparator Interrupt on Output Toggle |
| 0 | 1 | Reserved |
| 1 | 0 | Comparator Interrupt on Falling Output Edge |
| 1 | 1 | Comparator Interrupt on Rising Output Edge |

When changing the ACIS1/ACIS0 bits, the Analog Comparator Interrupt must be disabled by clearing its Interrupt Enable bit in the ACSR Register. Otherwise an interrupt can occur when the bits are changed.

Analog Comparator Multiplexed Input

It is possible to select any of the ADC7..0 pins to replace the negative input to the Analog Comparator. The ADC multiplexer is used to select this input, and consequently, the ADC must be switched off to utilize this feature. If the Analog Comparator Multiplexer Enable bit (ACME in SFIOR) is set and the ADC is switched off (ADEN in ADCSRA is zero), MUX2..0 in ADMUX select the input pin to replace the negative input to the Analog Comparator, as shown in Table

94. If ACME is cleared or ADEN is set, AIN1 is applied to the negative input to the Analog Comparator.

Table 94. Analog Comparator Multiplexed Input

| ACME | ADEN | MUX2..0 | Analog Comparator Negative Input |
|------|------|---------|----------------------------------|
| 0 | x | xxx | AIN1 |
| 1 | 1 | xxx | AIN1 |
| 1 | 0 | 000 | ADC0 |
| 1 | 0 | 001 | ADC1 |
| 1 | 0 | 010 | ADC2 |
| 1 | 0 | 011 | ADC3 |
| 1 | 0 | 100 | ADC4 |
| 1 | 0 | 101 | ADC5 |
| 1 | 0 | 110 | ADC6 |
| 1 | 0 | 111 | ADC7 |

Analog to Digital Converter

Features

- 10-bit Resolution
- 0.5LSB Integral Non-linearity
- ± 2 LSB Absolute Accuracy
- 13 - 260 μ s Conversion Time
- Up to 76.9kSPS (Up to 15 kSPS at Maximum Resolution)
- 8 Multiplexed Single Ended Input Channels
- 7 Differential Input Channels
- 2 Differential Input Channels with Optional Gain of 10x and 200x
- Optional Left Adjustment for ADC Result Readout
- 0 - VCC ADC Input Voltage Range
- Selectable 2.56V ADC Reference Voltage
- Free Running or Single Conversion Mode
- Interrupt on ADC Conversion Complete
- Sleep Mode Noise Canceler

The Atmel® AVR®ATmega128 features a 10-bit successive approximation ADC. The ADC is connected to an 8-channel Analog Multiplexer which allows 8 single-ended voltage inputs constructed from the pins of Port F. The single-ended voltage inputs refer to 0V (GND).

The device also supports 16 differential voltage input combinations. Two of the differential inputs (ADC1, ADC0 and ADC3, ADC2) are equipped with a programmable gain stage, providing amplification steps of 0 dB (1x), 20dB (10x), or 46dB (200x) on the differential input voltage before the A/D conversion. Seven differential analog input channels share a common negative terminal (ADC1), while any other ADC input can be selected as the positive input terminal. If 1x or 10x gain is used, 8-bit resolution can be expected. If 200x gain is used, 7-bit resolution can be expected.

The ADC contains a Sample and Hold circuit which ensures that the input voltage to the ADC is held at a constant level during conversion. A block diagram of the ADC is shown in [Figure 108](#).

The ADC has a separate analog supply voltage pin, AVCC. AVCC must not differ more than ± 0.3 V from V_{CC} . See the paragraph “[ADC Noise Canceler](#)” on [page 236](#) on how to connect this pin.

Internal reference voltages of nominally 2.56V or AVCC are provided On-chip. The voltage reference may be externally decoupled at the AREF pin by a capacitor for better noise performance.

Figure 108. Analog to Digital Converter Block Schematic



Operation

The ADC converts an analog input voltage to a 10-bit digital value through successive approximation. The minimum value represents GND and the maximum value represents the voltage on the AREF pin minus 1 SB. Optionally, AVCC or an internal 2.56V reference voltage may be connected to the AREF pin by writing to the REFSn bits in the ADMUX Register. The internal voltage reference may thus be decoupled by an external capacitor at the AREF pin to improve noise immunity.

The analog input channel and differential gain are selected by writing to the MUX bits in ADMUX. Any of the ADC input pins, as well as GND and a fixed bandgap voltage reference, can be selected as single ended inputs to the ADC. A selection of ADC input pins can be selected as positive and negative inputs to the differential gain amplifier.

If differential channels are selected, the differential gain stage amplifies the voltage difference between the selected input channel pair by the selected gain factor. This amplified value then becomes the analog input to the ADC. If single ended channels are used, the gain amplifier is bypassed altogether.

The ADC is enabled by setting the ADC Enable bit, ADEN in ADCSRA. Voltage reference and input channel selections will not go into effect until ADEN is set. The ADC does not consume power when ADEN is cleared, so it is recommended to switch off the ADC before entering power saving sleep modes.

The ADC generates a 10-bit result which is presented in the ADC Data Registers, ADCH and ADCL. By default, the result is presented right adjusted, but can optionally be presented left adjusted by setting the ADLAR bit in ADMUX.

If the result is left adjusted and no more than 8-bit precision is required, it is sufficient to read ADCH. Otherwise, ADCL must be read first, then ADCH, to ensure that the content of the data registers belongs to the same conversion. Once ADCL is read, ADC access to data registers is blocked. This means that if ADCL has been read, and a conversion completes before ADCH is read, neither register is updated and the result from the conversion is lost. When ADCH is read, ADC access to the ADCH and ADCL Registers is re-enabled.

The ADC has its own interrupt which can be triggered when a conversion completes. When ADC access to the data registers is prohibited between reading of ADCH and ADCL, the interrupt will trigger even if the result is lost.

Starting a Conversion

A single conversion is started by writing a logical one to the ADC Start Conversion bit, ADSC. This bit stays high as long as the conversion is in progress and will be cleared by hardware when the conversion is completed. If a different data channel is selected while a conversion is in progress, the ADC will finish the current conversion before performing the channel change.

In Free Running mode, the ADC is constantly sampling and updating the ADC Data Register. Free Running mode is selected by writing the ADFR bit in ADCSRA to one. The first conversion must be started by writing a logical one to the ADSC bit in ADCSRA. In this mode the ADC will perform successive conversions independently of whether the ADC Interrupt Flag, ADIF is cleared or not.

Prescaling and Conversion Timing

Figure 109. ADC Prescaler



By default, the successive approximation circuitry requires an input clock frequency between 50kHz and 200kHz to get maximum resolution. If a lower resolution than 10 bits is needed, the input clock frequency to the ADC can be higher than 200kHz to get a higher sample rate.

The ADC module contains a prescaler, which generates an acceptable ADC clock frequency from any CPU frequency above 100kHz. The prescaling is set by the ADPS bits in ADCSRA. The prescaler starts counting from the moment the ADC is switched on by setting the ADEN bit in ADCSRA. The prescaler keeps running for as long as the ADEN bit is set, and is continuously reset when ADEN is low.

When initiating a single ended conversion by setting the ADSC bit in ADCSRA, the conversion starts at the following rising edge of the ADC clock cycle. See [“Differential Gain Channels” on page 235](#) for details on differential conversion timing.

A normal conversion takes 13 ADC clock cycles. The first conversion after the ADC is switched on (ADEN in ADCSRA is set) takes 25 ADC clock cycles in order to initialize the analog circuitry.

The actual sample-and-hold takes place 1.5 ADC clock cycles after the start of a normal conversion and 13.5 ADC clock cycles after the start of an first conversion. When a conversion is complete, the result is written to the ADC data registers, and ADIF is set. In single conversion mode, ADSC is cleared simultaneously. The software may then set ADSC again, and a new conversion will be initiated on the first rising ADC clock edge.

In Free Running mode, a new conversion will be started immediately after the conversion completes, while ADSC remains high. For a summary of conversion times, see [Table 95](#).

Figure 110. ADC Timing Diagram, First Conversion (Single Conversion Mode)



Figure 111. ADC Timing Diagram, Single Conversion



Figure 112. ADC Timing Diagram, Free Running Conversion



Table 95. ADC Conversion Time

| Condition | Sample & Hold (Cycles from Start of Conversion) | Conversion Time (Cycles) |
|----------------------------------|---|--------------------------|
| First conversion | 13.5 | 25 |
| Normal conversions, single ended | 1.5 | 13 |
| Normal conversions, differential | 1.5/2.5 | 13/14 |

Differential Gain Channels

When using differential gain channels, certain aspects of the conversion need to be taken into consideration.

Differential conversions are synchronized to the internal clock CK_{ADC2} equal to half the ADC clock. This synchronization is done automatically by the ADC interface in such a way that the sample-and-hold occurs at a specific edge of CK_{ADC2} . A conversion initiated by the user (i.e., all single conversions, and the first free running conversion) when CK_{ADC2} is low will take the same amount of time as a single ended conversion (13 ADC clock cycles from the next prescaled clock cycle). A conversion initiated by the user when CK_{ADC2} is high will take 14 ADC clock cycles due to the synchronization mechanism. In free running mode, a new conversion is initiated immediately after the previous conversion completes, and since CK_{ADC2} is high at this time, all automatically started (i.e., all but the first) free running conversions will take 14 ADC clock cycles.

The gain stage is optimized for a bandwidth of 4kHz at all gain settings. Higher frequencies may be subjected to non-linear amplification. An external low-pass filter should be used if the input signal contains higher frequency components than the gain stage bandwidth. Note that the ADC clock frequency is independent of the gain stage bandwidth limitation. E.g. the ADC clock period may be 6 μ s, allowing a channel to be sampled at 12kSPS, regardless of the bandwidth of this channel.

Changing Channel or Reference Selection

The MUXn and REFS1:0 bits in the ADMUX Register are single buffered through a temporary register to which the CPU has random access. This ensures that the channels and reference selection only takes place at a safe point during the conversion. The channel and reference selection is continuously updated until a conversion is started. Once the conversion starts, the channel and reference selection is locked to ensure a sufficient sampling time for the ADC. Continuous updating resumes in the last ADC clock cycle before the conversion completes (ADIF in ADCSRA is set). Note that the conversion starts on the following rising ADC clock edge after ADSC is written. The user is thus advised not to write new channel or reference selection values to ADMUX until one ADC clock cycle after ADSC is written.

Special care should be taken when changing differential channels. Once a differential channel has been selected, the gain stage may take as much as 125 μ s to stabilize to the new value. Thus conversions should not be started within the first 125 μ s after selecting a new differential channel. Alternatively, conversion results obtained within this period should be discarded.

The same settling time should be observed for the first differential conversion after changing ADC reference (by changing the REFS1:0 bits in ADMUX).

If the JTAG Interface is enabled, the function of ADC channels on PORTF7:4 is overridden. Refer to [Table 42, "Port F Pins Alternate Functions,"](#) on page 82.

ADC Input Channels

When changing channel selections, the user should observe the following guidelines to ensure that the correct channel is selected:

In Single Conversion mode, always select the channel before starting the conversion. The channel selection may be changed one ADC clock cycle after writing one to ADSC. However, the simplest method is to wait for the conversion to complete before changing the channel selection.

In Free Running mode, always select the channel before starting the first conversion. The channel selection may be changed one ADC clock cycle after writing one to ADSC. However, the simplest method is to wait for the first conversion to complete, and then change the channel selection. Since the next conversion has already started automatically, the next result will reflect the previous channel selection. Subsequent conversions will reflect the new channel selection.

When switching to a differential gain channel, the first conversion result may have a poor accuracy due to the required settling time for the automatic offset cancellation circuitry. The user should preferably disregard the first conversion result.

ADC Voltage Reference

The reference voltage for the ADC (V_{REF}) indicates the conversion range for the ADC. Single ended channels that exceed V_{REF} will result in codes close to 0x3FF. V_{REF} can be selected as either AV_{CC} , internal 2.56V reference, or external AREF pin.

AV_{CC} is connected to the ADC through a passive switch. The internal 2.56V reference is generated from the internal bandgap reference (V_{BG}) through an internal amplifier. In either case, the external AREF pin is directly connected to the ADC, and the reference voltage can be made more immune to noise by connecting a capacitor between the AREF pin and ground. V_{REF} can also be measured at the AREF pin with a high impedant voltmeter. Note that V_{REF} is a high impedant source, and only a capacitive load should be connected in a system.

If the user has a fixed voltage source connected to the AREF pin, the user may not use the other reference voltage options in the application, as they will be shorted to the external voltage. If no external voltage is applied to the AREF pin, the user may switch between AV_{CC} and 2.56 V as reference selection. The first ADC conversion result after switching reference voltage source may be inaccurate, and the user is advised to discard this result.

If differential channels are used, the selected reference should not be closer to AV_{CC} than indicated in [Table 136 on page 326](#).

ADC Noise Canceler

The ADC features a noise canceler that enables conversion during sleep mode to reduce noise induced from the CPU core and other I/O peripherals. The noise canceler can be used with ADC Noise Reduction and Idle mode. To make use of this feature, the following procedure should be used:

1. Make sure that the ADC is enabled and is not busy converting. Single Conversion mode must be selected and the ADC conversion complete interrupt must be enabled.
2. Enter ADC Noise Reduction mode (or Idle mode). The ADC will start a conversion once the CPU has been halted.
3. If no other interrupts occur before the ADC conversion completes, the ADC interrupt will wake up the CPU and execute the ADC Conversion Complete interrupt routine. If another interrupt wakes up the CPU before the ADC conversion is complete, that interrupt will be executed, and an ADC Conversion Complete interrupt request will be generated when the ADC conversion completes. The CPU will remain in active mode until a new sleep command is executed.

Note that the ADC will not be automatically turned off when entering other sleep modes than Idle mode and ADC Noise Reduction mode. The user is advised to write zero to ADEN before entering such sleep modes to avoid excessive power consumption. If the ADC is enabled in such

sleep modes and the user wants to perform differential conversions, the user is advised to switch the ADC off and on after waking up from sleep to prompt an extended conversion to get a valid result.

Analog Input Circuitry

The Analog Input circuitry for single ended channels is illustrated in [Figure 113](#). An analog source applied to ADCn is subjected to the pin capacitance and input leakage of that pin, regardless of whether that channel is selected as input for the ADC. When the channel is selected, the source must drive the S/H capacitor through the series resistance (combined resistance in the input path).

The ADC is optimized for analog signals with an output impedance of approximately 10kΩ or less. If such a source is used, the sampling time will be negligible. If a source with higher impedance is used, the sampling time will depend on how long time the source needs to charge the S/H capacitor, which can vary widely. The user is recommended to only use low impedance sources with slowly varying signals, since this minimizes the required charge transfer to the S/H capacitor.

If differential gain channels are used, the input circuitry looks somewhat different, although source impedances of a few hundred kΩ or less is recommended.

Signal components higher than the Nyquist frequency ($f_{ADC} / 2$) should not be present for either kind of channels, to avoid distortion from unpredictable signal convolution. The user is advised to remove high frequency components with a low-pass filter before applying the signals as inputs to the ADC.

Figure 113. Analog Input Circuitry

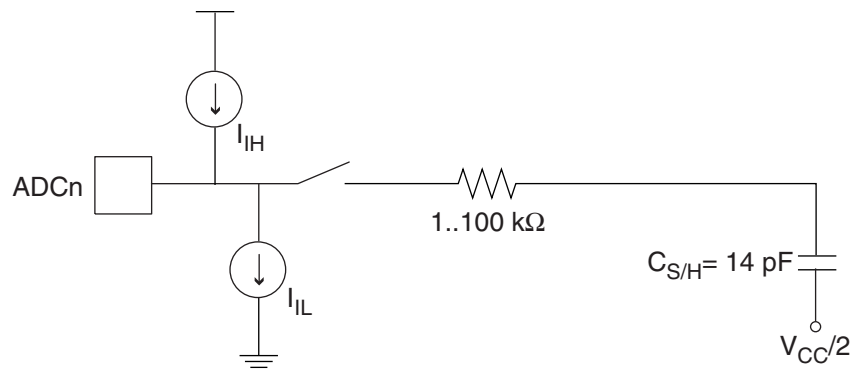

Analog Noise Canceling Techniques

Digital circuitry inside and outside the device generates EMI which might affect the accuracy of analog measurements. If conversion accuracy is critical, the noise level can be reduced by applying the following techniques:

1. Keep analog signal paths as short as possible. Make sure analog tracks run over the ground plane, and keep them well away from high-speed switching digital tracks.
2. The AVCC pin on the device should be connected to the digital V_{CC} supply voltage via an LC network as shown in [Figure 114](#).
3. Use the ADC noise canceler function to reduce induced noise from the CPU.
4. If any ADC port pins are used as digital outputs, it is essential that these do not switch while a conversion is in progress.

Figure 114. ADC Power Connections



Offset Compensation Schemes

The gain stage has a built-in offset cancellation circuitry that nulls the offset of differential measurements as much as possible. The remaining offset in the analog path can be measured directly by selecting the same channel for both differential inputs. This offset residue can be then subtracted in software from the measurement results. Using this kind of software based offset correction, offset on any channel can be reduced below one LSB.

ADC Accuracy Definitions

An n-bit single-ended ADC converts a voltage linearly between GND and V_{REF} in 2^n steps (LSBs). The lowest code is read as 0, and the highest code is read as 2^n-1 .

Several parameters describe the deviation from the ideal behavior:

- Offset: The deviation of the first transition (0x000 to 0x001) compared to the ideal transition (at 0.5LSB). Ideal value: 0LSB.

Figure 115. Offset Error



- Gain Error: After adjusting for offset, the gain error is found as the deviation of the last transition (0x3FE to 0x3FF) compared to the ideal transition (at 1.5LSB below maximum). Ideal value: 0LSB

Figure 116. Gain Error



- Integral Non-linearity (INL): After adjusting for offset and gain error, the INL is the maximum deviation of an actual transition compared to an ideal transition for any code. Ideal value: 0LSB.

Figure 117. Integral Non-linearity (INL)



- **Differential Non-linearity (DNL):** The maximum deviation of the actual code width (the interval between two adjacent transitions) from the ideal code width (1LSB). Ideal value: 0LSB.

Figure 118. Differential Non-linearity (DNL)

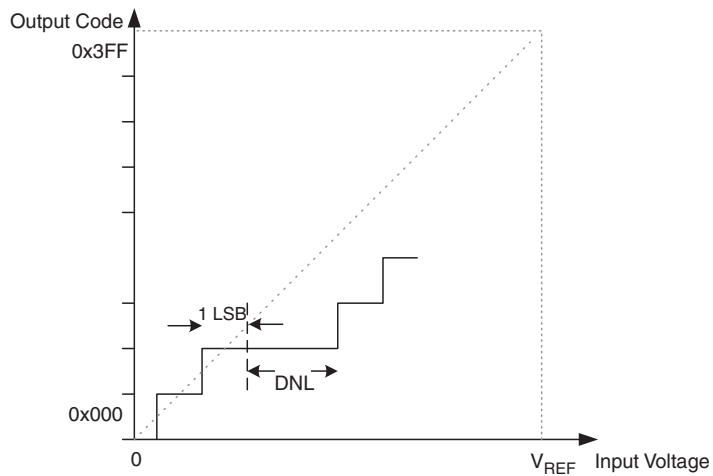

- **Quantization Error:** Due to the quantization of the input voltage into a finite number of codes, a range of input voltages (1LSB wide) will code to the same value. Always $\pm 0.5\text{LSB}$.
- **Absolute Accuracy:** The maximum deviation of an actual (unadjusted) transition compared to an ideal transition for any code. This is the compound effect of offset, gain error, differential error, non-linearity, and quantization error. Ideal value: $\pm 0.5\text{LSB}$.

ADC Conversion Result

After the conversion is complete (ADIF is high), the conversion result can be found in the ADC Result Registers (ADCL, ADCH).

For single ended conversion, the result is

$$ADC = \frac{V_{IN} \cdot 1024}{V_{REF}}$$

where V_{IN} is the voltage on the selected input pin and V_{REF} the selected voltage reference (see [Table 97 on page 242](#) and [Table 98 on page 243](#)). 0x000 represents ground, and 0x3FF represents the selected reference voltage minus one LSB.

If differential channels are used, the result is

$$ADC = \frac{(V_{POS} - V_{NEG}) \cdot GAIN \cdot 512}{V_{REF}}$$

where V_{POS} is the voltage on the positive input pin, V_{NEG} the voltage on the negative input pin, GAIN the selected gain factor, and V_{REF} the selected voltage reference. The result is presented in two's complement form, from 0x200 (-512d) through 0x1FF (+511d). Note that if the user wants to perform a quick polarity check of the results, it is sufficient to read the MSB of the result (ADC9 in ADCH). If this bit is one, the result is negative, and if this bit is zero, the result is positive. [Figure 119](#) shows the decoding of the differential input range.

[Table 96](#) shows the resulting output codes if the differential input channel pair (ADCn - ADCm) is selected with a gain of GAIN and a reference voltage of V_{REF} .

Figure 119. Differential Measurement Range

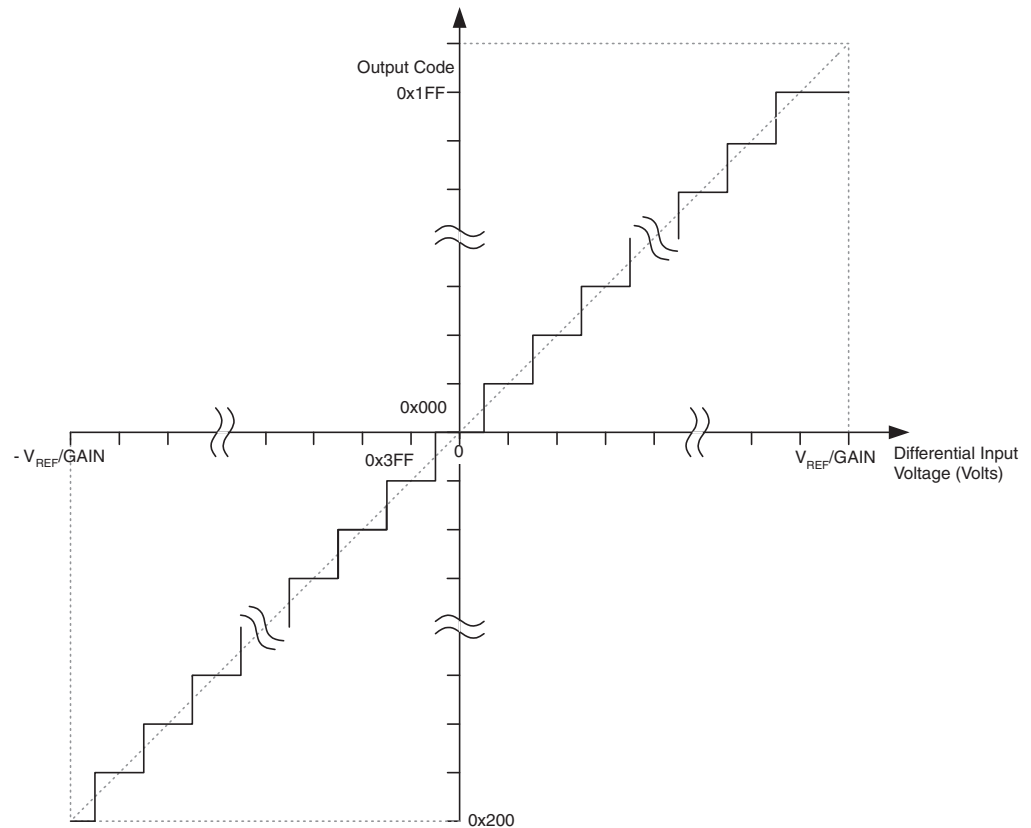

Table 96. Correlation Between Input Voltage and Output Codes

| V_{ADCn} | Read code | Corresponding decimal value |
|-----------------------------------|-----------|-----------------------------|
| $V_{ADCm} + V_{REF}/GAIN$ | 0x1FF | 511 |
| $V_{ADCm} + 511/512 V_{REF}/GAIN$ | 0x1FF | 511 |
| $V_{ADCm} + 511/512 V_{REF}/GAIN$ | 0x1FE | 510 |
| ... | ... | ... |
| $V_{ADCm} + 1/512 V_{REF}/GAIN$ | 0x001 | 1 |
| V_{ADCm} | 0x000 | 0 |
| $V_{ADCm} - 1/512 V_{REF}/GAIN$ | 0x3FF | -1 |
| ... | ... | ... |
| $V_{ADCm} - 511/512 V_{REF}/GAIN$ | 0x201 | -511 |
| $V_{ADCm} - V_{REF}/GAIN$ | 0x200 | -512 |

Example:

ADMUX = 0xED (ADC3 - ADC2, 10x gain, 2.56V reference, left adjusted result)

Voltage on ADC3 is 300mV, voltage on ADC2 is 500mV.

ADCR = $512 * 10 * (300 - 500) / 2560 = -400 = 0x270$

ADCL will thus read 0x00, and ADCH will read 0x9C. Writing zero to ADLAR right adjusts the result: ADCL = 0x70, ADCH = 0x02.

ADC Multiplexer Selection Register – ADMUX

| | | | | | | | | | |
|---------------|-------|-------|-------|------|------|------|------|------|-------|
| Bit | 7 | 6 | 5 | 4 | 3 | 2 | 1 | 0 | |
| | REFS1 | REFS0 | ADLAR | MUX4 | MUX3 | MUX2 | MUX1 | MUX0 | ADMUX |
| Read/Write | R/W | R/W | R/W | R/W | R/W | R/W | R/W | R/W | |
| Initial Value | 0 | 0 | 0 | 0 | 0 | 0 | 0 | 0 | |

- **Bit 7:6 – REFS1:0: Reference Selection Bits**

These bits select the voltage reference for the ADC, as shown in Table 97. If these bits are changed during a conversion, the change will not go in effect until this conversion is complete (ADIF in ADCSRA is set). The internal voltage reference options may not be used if an external reference voltage is being applied to the AREF pin.

Table 97. Voltage Reference Selections for ADC

| REFS1 | REFS0 | Voltage Reference Selection |
|-------|-------|--|
| 0 | 0 | AREF, Internal Vref turned off |
| 0 | 1 | AVCC with external capacitor at AREF pin |
| 1 | 0 | Reserved |
| 1 | 1 | Internal 2.56V Voltage Reference with external capacitor at AREF pin |

- **Bit 5 – ADLAR: ADC Left Adjust Result**

The ADLAR bit affects the presentation of the ADC conversion result in the ADC Data Register. Write one to ADLAR to left adjust the result. Otherwise, the result is right adjusted. Changing the ADLAR bit will affect the ADC Data Register immediately, regardless of any ongoing

conversions. For a complete description of this bit, see “The ADC Data Register – ADCL and ADCH” on page 245.

• **Bits 4:0 – MUX4:0: Analog Channel and Gain Selection Bits**

The value of these bits selects which combination of analog inputs are connected to the ADC. These bits also select the gain for the differential channels. See Table 98 for details. If these bits are changed during a conversion, the change will not go in effect until this conversion is complete (ADIF in ADCSRA is set).

Table 98. Input Channel and Gain Selections

| MUX4..0 | Single Ended Input | Positive Differential Input | Negative Differential Input | Gain |
|----------------------|--------------------|-----------------------------|-----------------------------|------|
| 00000 | ADC0 | N/A | | |
| 00001 | ADC1 | | | |
| 00010 | ADC2 | | | |
| 00011 | ADC3 | | | |
| 00100 | ADC4 | | | |
| 00101 | ADC5 | | | |
| 00110 | ADC6 | | | |
| 00111 | ADC7 | | | |
| 01000 ⁽¹⁾ | | ADC0 | ADC0 | 10x |
| 01001 | | ADC1 | ADC0 | 10x |
| 01010 ⁽¹⁾ | N/A | ADC0 | ADC0 | 200x |
| 01011 | | ADC1 | ADC0 | 200x |
| 01100 | | ADC2 | ADC2 | 10x |
| 01101 | | ADC3 | ADC2 | 10x |
| 01110 | | ADC2 | ADC2 | 200x |
| 01111 | | ADC3 | ADC2 | 200x |
| 10000 | | ADC0 | ADC1 | 1x |
| 10001 | | ADC1 | ADC1 | 1x |
| 10010 | | ADC2 | ADC1 | 1x |
| 10011 | | ADC3 | ADC1 | 1x |
| 10100 | | ADC4 | ADC1 | 1x |
| 10101 | | ADC5 | ADC1 | 1x |
| 10110 | | ADC6 | ADC1 | 1x |
| 10111 | | ADC7 | ADC1 | 1x |
| 11000 | | ADC0 | ADC2 | 1x |
| 11001 | | ADC1 | ADC2 | 1x |
| 11010 | ADC2 | ADC2 | 1x | |
| 11011 | ADC3 | ADC2 | 1x | |
| 11100 | ADC4 | ADC2 | 1x | |

Table 98. Input Channel and Gain Selections (Continued)

| MUX4..0 | Single Ended Input | Positive Differential Input | Negative Differential Input | Gain |
|---------|--------------------|-----------------------------|-----------------------------|------|
| 11101 | | ADC5 | ADC2 | 1x |
| 11110 | 1.23V (V_{BG}) | N/A | | |
| 11111 | 0V (GND) | | | |

Note: 1. Can be used for offset calibration.

ADC Control and Status Register A – ADCSRA

| Bit | 7 | 6 | 5 | 4 | 3 | 2 | 1 | 0 | |
|---------------|------|------|------|------|------|-------|-------|-------|--------|
| | ADEN | ADSC | ADFR | ADIF | ADIE | ADPS2 | ADPS1 | ADPS0 | ADCSRA |
| Read/Write | R/W | R/W | R/W | R/W | R/W | R/W | R/W | R/W | |
| Initial Value | 0 | 0 | 0 | 0 | 0 | 0 | 0 | 0 | |

- **Bit 7 – ADEN: ADC Enable**

Writing this bit to one enables the ADC. By writing it to zero, the ADC is turned off. Turning the ADC off while a conversion is in progress, will terminate this conversion.

- **Bit 6 – ADSC: ADC Start Conversion**

In Single Conversion mode, write this bit to one to start each conversion. In Free Running mode, write this bit to one to start the first conversion. The first conversion after ADSC has been written after the ADC has been enabled, or if ADSC is written at the same time as the ADC is enabled, will take 25 ADC clock cycles instead of the normal 13. This first conversion performs initialization of the ADC.

ADSC will read as one as long as a conversion is in progress. When the conversion is complete, it returns to zero. Writing zero to this bit has no effect.

- **Bit 5 – ADFR: ADC Free Running Select**

When this bit is written to one, the ADC operates in Free Running mode. In this mode, the ADC samples and updates the data registers continuously. Writing zero to this bit will terminate Free Running mode.

- **Bit 4 – ADIF: ADC Interrupt Flag**

This bit is set when an ADC conversion completes and the data registers are updated. The ADC Conversion Complete Interrupt is executed if the ADIE bit and the I-bit in SREG are set. ADIF is cleared by hardware when executing the corresponding interrupt handling vector. Alternatively, ADIF is cleared by writing a logical one to the flag. Beware that if doing a read-modify-write on ADCSRA, a pending interrupt can be disabled. This also applies if the SBI and CBI instructions are used.

- **Bit 3 – ADIE: ADC Interrupt Enable**

When this bit is written to one and the I-bit in SREG is set, the ADC Conversion Complete Interrupt is activated.

- **Bits 2:0 – ADPS2:0: ADC Prescaler Select Bits**

These bits determine the division factor between the XTAL frequency and the input clock to the ADC.

Table 99. ADC Prescaler Selections

| ADPS2 | ADPS1 | ADPS0 | Division Factor |
|-------|-------|-------|-----------------|
| 0 | 0 | 0 | 2 |
| 0 | 0 | 1 | 2 |
| 0 | 1 | 0 | 4 |
| 0 | 1 | 1 | 8 |
| 1 | 0 | 0 | 16 |
| 1 | 0 | 1 | 32 |
| 1 | 1 | 0 | 64 |
| 1 | 1 | 1 | 128 |

The ADC Data Register – ADCL and ADCH

ADLAR = 0:

| Bit | 15 | 14 | 13 | 12 | 11 | 10 | 9 | 8 | |
|---------------|------|------|------|------|------|------|------|------|------|
| | – | – | – | – | – | – | ADC9 | ADC8 | ADCH |
| | ADC7 | ADC6 | ADC5 | ADC4 | ADC3 | ADC2 | ADC1 | ADC0 | ADCL |
| Read/Write | R | R | R | R | R | R | R | R | |
| Initial Value | 0 | 0 | 0 | 0 | 0 | 0 | 0 | 0 | |

ADLAR = 1:

| Bit | 15 | 14 | 13 | 12 | 11 | 10 | 9 | 8 | |
|---------------|------|------|------|------|------|------|------|------|------|
| | ADC9 | ADC8 | ADC7 | ADC6 | ADC5 | ADC4 | ADC3 | ADC2 | ADCH |
| | ADC1 | ADC0 | – | – | – | – | – | – | ADCL |
| Read/Write | R | R | R | R | R | R | R | R | |
| Initial Value | 0 | 0 | 0 | 0 | 0 | 0 | 0 | 0 | |

When an ADC conversion is complete, the result is found in these two registers. If differential channels are used, the result is presented in two’s complement form.

When ADCL is read, the ADC Data Register is not updated until ADCH is read. Consequently, if the result is left adjusted and no more than 8-bit precision is required, it is sufficient to read ADCH. Otherwise, ADCL must be read first, then ADCH.

The ADLAR bit in ADMUX, and the MUXn bits in ADMUX affect the way the result is read from the registers. If ADLAR is set, the result is left adjusted. If ADLAR is cleared (default), the result is right adjusted.

• **ADC9:0: ADC Conversion Result**

These bits represent the result from the conversion, as detailed in [“ADC Conversion Result” on page 241](#).

JTAG Interface and On-chip Debug System

Features

- JTAG (IEEE std. 1149.1 Compliant) Interface
- Boundary-scan Capabilities According to the IEEE std. 1149.1 (JTAG) Standard
- Debugger Access to:
 - All Internal Peripheral Units
 - Internal and External RAM
 - The Internal Register File
 - Program Counter
 - EEPROM and Flash Memories
- Extensive On-chip Debug Support for Break Conditions, Including
 - AVR *Break* Instruction
 - Break on Change of Program Memory Flow
 - Single Step Break
 - Program Memory Breakpoints on Single Address or Address Range
 - Data Memory Breakpoints on Single Address or Address Range
- Programming of Flash, EEPROM, Fuses, and Lock Bits through the JTAG Interface
- On-chip Debugging Supported by AVR Studio

Overview

The AVR IEEE std. 1149.1 compliant JTAG interface can be used for

- Testing PCBs by using the JTAG Boundary-scan capability
- Programming the non-volatile memories, Fuses and Lock bits
- On-chip debugging

A brief description is given in the following sections. Detailed descriptions for Programming via the JTAG interface, and using the Boundary-scan Chain can be found in the sections [“Programming Via the JTAG Interface” on page 305](#) and [“IEEE 1149.1 \(JTAG\) Boundary-scan” on page 252](#), respectively. The On-chip Debug support is considered being private JTAG instructions, and distributed within ATMEL and to selected third party vendors only.

[Figure 120](#) shows a block diagram of the JTAG interface and the On-chip Debug system. The TAP Controller is a state machine controlled by the TCK and TMS signals. The TAP Controller selects either the JTAG Instruction Register or one of several Data Registers as the scan chain (Shift Register) between the TDI – input and TDO – output. The Instruction Register holds JTAG instructions controlling the behavior of a Data Register.

The ID-Register, Bypass Register, and the Boundary-scan Chain are the data registers used for board-level testing. The JTAG Programming Interface (actually consisting of several physical and virtual Data Registers) is used for serial programming via the JTAG interface. The Internal Scan Chain and Break Point Scan Chain are used for On-chip debugging only.

Test Access Port – TAP

The JTAG interface is accessed through four of the AVR’s pins. In JTAG terminology, these pins constitute the Test Access Port — TAP. These pins are:

- TMS: Test mode select. This pin is used for navigating through the TAP-controller state machine.
- TCK: Test clock. JTAG operation is synchronous to TCK.
- TDI: Test Data In. Serial input data to be shifted in to the Instruction Register or Data Register (Scan Chains).
- TDO: Test Data Out. Serial output data from Instruction Register or Data Register.

The IEEE std. 1149.1 also specifies an optional TAP signal; TRST – Test ReSeT – which is not provided.

When the JTAGEN fuse is unprogrammed, these four TAP pins are normal port pins and the TAP controller is in reset. When programmed and the JTD bit in MCUCSR is cleared, the TAP input signals are internally pulled high and the JTAG is enabled for Boundary-scan and programming. In this case, the TAP output pin (TDO) is left floating in states where the JTAG TAP controller is not shifting data, and must therefore be connected to a pull-up resistor or other hardware having pull-ups (for instance the TDI-input of the next device in the scan chain). The device is shipped with this fuse programmed.

For the On-chip Debug system, in addition to the JTAG interface pins, the $\overline{\text{RESET}}$ pin is monitored by the debugger to be able to detect External Reset sources. The debugger can also pull the $\overline{\text{RESET}}$ pin low to reset the whole system, assuming only open collectors on the Reset line are used in the application.

Figure 120. Block Diagram



Figure 121. TAP Controller State Diagram



TAP Controller

The TAP controller is a 16-state finite state machine that controls the operation of the Boundary-scan circuitry, JTAG programming circuitry, or On-chip Debug system. The state transitions depicted in Figure 121 depend on the signal present on TMS (shown adjacent to each state transition) at the time of the rising edge at TCK. The initial state after a Power-on Reset is Test-Logic-Reset.

As a definition in this document, the LSB is shifted in and out first for all Shift Registers.

Assuming Run-Test/Idle is the present state, a typical scenario for using the JTAG interface is:

- At the TMS input, apply the sequence 1, 1, 0, 0 at the rising edges of TCK to enter the Shift Instruction Register – Shift-IR state. While in this state, shift the 4 bits of the JTAG instructions into the JTAG instruction register from the TDI input at the rising edge of TCK. The TMS input must be held low during input of the 3LSB in order to remain in the Shift-IR state. The MSB of the instruction is shifted in when this state is left by setting TMS high. While the instruction is shifted in from the TDI pin, the captured IR-state 0x01 is shifted out

on the TDO pin. The JTAG Instruction selects a particular Data Register as path between TDI and TDO and controls the circuitry surrounding the selected Data Register.

- Apply the TMS sequence 1, 1, 0 to re-enter the Run-Test/Idle state. The instruction is latched onto the parallel output from the Shift Register path in the Update-IR state. The Exit-IR, Pause-IR, and Exit2-IR states are only used for navigating the state machine.
- At the TMS input, apply the sequence 1, 0, 0 at the rising edges of TCK to enter the Shift Data Register – Shift-DR state. While in this state, upload the selected Data Register (selected by the present JTAG instruction in the JTAG Instruction Register) from the TDI input at the rising edge of TCK. In order to remain in the Shift-DR state, the TMS input must be held low during input of all bits except the MSB. The MSB of the data is shifted in when this state is left by setting TMS high. While the Data Register is shifted in from the TDI pin, the parallel inputs to the Data Register captured in the Capture-DR state is shifted out on the TDO pin.
- Apply the TMS sequence 1, 1, 0 to re-enter the Run-Test/Idle state. If the selected Data Register has a latched parallel-output, the latching takes place in the Update-DR state. The Exit-DR, Pause-DR, and Exit2-DR states are only used for navigating the state machine.

As shown in the state diagram, the Run-Test/Idle state need not be entered between selecting JTAG instruction and using Data Registers, and some JTAG instructions may select certain functions to be performed in the Run-Test/Idle, making it unsuitable as an Idle state.

Note: Independent of the initial state of the TAP Controller, the Test-Logic-Reset state can always be entered by holding TMS high for 5 TCK clock periods.

For detailed information on the JTAG specification, refer to the literature listed in [“Bibliography” on page 251](#).

Using the Boundary-scan Chain

A complete description of the Boundary-scan capabilities are given in the section [“IEEE 1149.1 \(JTAG\) Boundary-scan” on page 252](#).

Using the On-chip Debug System

As shown in [Figure 120](#), the hardware support for On-chip Debugging consists mainly of

- A scan chain on the interface between the internal AVR CPU and the internal peripheral units
- Break point unit
- Communication interface between the CPU and JTAG system

All read or modify/write operations needed for implementing the Debugger are done by applying AVR instructions via the internal AVR CPU Scan Chain. The CPU sends the result to an I/O memory mapped location which is part of the communication interface between the CPU and the JTAG system.

The Break point Unit implements Break on Change of Program Flow, Single Step Break, two Program Memory Breakpoints, and two combined break points. Together, the four break points can be configured as either:

- 4 single Program Memory break points
- 3 Single Program Memory break point + 1 single Data Memory break point
- 2 single Program Memory break points + 2 single Data Memory break points
- 2 single Program Memory break points + 1 Program Memory break point with mask (“range break point”)
- 2 single Program Memory break points + 1 Data Memory break point with mask “range break point”.

A debugger, like the Atmel® AVR Studio®, may however use one or more of these resources for its internal purpose, leaving less flexibility to the end-user.

A list of the On-chip Debug specific JTAG instructions is given in [“On-chip Debug Specific JTAG Instructions” on page 250](#).

The JTAGEN fuse must be programmed to enable the JTAG Test Access Port. In addition, the OCDEN fuse must be programmed and no Lock bits must be set for the On-chip Debug system to work. As a security feature, the On-chip Debug system is disabled when *any* Lock bits are set. Otherwise, the On-chip Debug system would have provided a back-door into a secured device.

The AVR Studio enables the user to fully control execution of programs on an AVR device with On-chip Debug capability, AVR In-Circuit Emulator, or the built-in AVR Instruction Set Simulator. AVR Studio supports source level execution of Assembly programs assembled with Atmel Corporation’s AVR Assembler and C programs compiled with third party vendors’ compilers.

AVR Studio runs under Microsoft® Windows® 95/98/2000 and Windows NT® and Windows XP®.

For a full description of the AVR Studio, please refer to the **AVR Studio User Guide** found in the Online Help in AVR Studio. Only highlights are presented in this document.

All necessary execution commands are available in AVR Studio, both on source level and on disassembly level. The user can execute the program, single step through the code either by tracing into or stepping over functions, step out of functions, place the cursor on a statement and execute until the statement is reached, stop the execution, and reset the execution target. In addition, the user can have an unlimited number of code break points (using the BREAK instruction) and up to two data memory break points, alternatively combined as a mask (range) break point.

On-chip Debug Specific JTAG Instructions

The On-chip debug support is considered being private JTAG instructions, and distributed within ATMEL and to selected third-party vendors only. Instruction opcodes are listed for reference.

| | |
|----------------------|--|
| PRIVATE0; \$8 | Private JTAG instruction for accessing On-chip Debug system. |
| PRIVATE1; \$9 | Private JTAG instruction for accessing On-chip Debug system. |
| PRIVATE2; \$A | Private JTAG instruction for accessing On-chip Debug system. |
| PRIVATE3; \$B | Private JTAG instruction for accessing On-chip Debug system. |

On-chip Debug Related Register in I/O Memory

On-chip Debug Register – OCDR

| | | | | | | | | | |
|---------------|-----------------|-----|-----|-----|-----|-----|-----|------------|-------------|
| Bit | 7 | 6 | 5 | 4 | 3 | 2 | 1 | 0 | |
| | MSB/IDRD | | | | | | | LSB | OCDR |
| Read/Write | R/W | R/W | R/W | R/W | R/W | R/W | R/W | R/W | |
| Initial Value | 0 | 0 | 0 | 0 | 0 | 0 | 0 | 0 | |

The OCDR Register provides a communication channel from the running program in the micro-controller to the debugger. The CPU can transfer a byte to the debugger by writing to this location. At the same time, an internal flag; I/O Debug Register Dirty – IDRD – is set to indicate to the debugger that the register has been written. When the CPU reads the OCDR Register the 7LSB will be from the OCDR Register, while the MSB is the IDRD bit. The debugger clears the IDRD bit when it has read the information.

In some AVR devices, this register is shared with a standard I/O location. In this case, the OCDR Register can only be accessed if the OCDEN fuse is programmed, and the debugger enables access to the OCDR Register. In all other cases, the standard I/O location is accessed.

Refer to the debugger documentation for further information on how to use this register.

Using the JTAG Programming Capabilities

Programming of Atmel® AVR® devices via JTAG is performed via the four-pin JTAG port, TCK, TMS, TDI, and TDO. These are the only pins that need to be controlled/observed to perform JTAG programming (in addition to power pins). It is not required to apply 12V externally. The JTAGEN fuse must be programmed and the JTD bit in the MCUCSR Register must be cleared to enable the JTAG Test Access Port.

The JTAG programming capability supports:

- Flash programming and verifying
- EEPROM programming and verifying
- Fuse programming and verifying
- Lock bit programming and verifying

The Lock bit security is exactly as in Parallel Programming mode. If the Lock bits LB1 or LB2 are programmed, the OCDEN Fuse cannot be programmed unless first doing a chip erase. This is a security feature that ensures no back-door exists for reading out the content of a secured device.

The details on programming through the JTAG interface and programming specific JTAG instructions are given in the section [“Programming Via the JTAG Interface” on page 305](#).

Bibliography

For more information about general Boundary-scan, the following literature can be consulted:

- IEEE: IEEE Std 1149.1-1990. IEEE Standard Test Access Port and Boundary-scan Architecture, IEEE, 1993
- Colin Maunder: The Board Designers Guide to Testable Logic Circuits, Addison-Wesley, 1992

IEEE 1149.1 (JTAG) Boundary- scan

Features

- JTAG (IEEE std. 1149.1 Compliant) Interface
- Boundary-scan Capabilities According to the JTAG Standard
- Full Scan of all Port Functions as well as Analog Circuitry having Off-chip Connections
- Supports the Optional IDCODE Instruction
- Additional Public AVR_RESET Instruction to Reset the AVR

System Overview

The Boundary-scan Chain has the capability of driving and observing the logic levels on the digital I/O pins, as well as the boundary between digital and analog logic for analog circuitry having off-chip connections. At system level, all ICs having JTAG capabilities are connected serially by the TDI/TDO signals to form a long Shift Register. An external controller sets up the devices to drive values at their output pins, and observe the input values received from other devices. The controller compares the received data with the expected result. In this way, Boundary-scan provides a mechanism for testing interconnections and integrity of components on Printed Circuits Boards by using the four TAP signals only.

The four IEEE 1149.1 defined mandatory JTAG instructions IDCODE, BYPASS, SAMPLE/PRELOAD, and EXTEST, as well as the AVR specific public JTAG instruction AVR_RESET can be used for testing the Printed Circuit Board. Initial scanning of the data register path will show the ID-code of the device, since IDCODE is the default JTAG instruction. It may be desirable to have the AVR device in reset during Test mode. If not reset, inputs to the device may be determined by the scan operations, and the internal software may be in an undetermined state when exiting the Test mode. Entering Reset, the outputs of any Port Pin will instantly enter the high impedance state, making the HIGHZ instruction redundant. If needed, the BYPASS instruction can be issued to make the shortest possible scan chain through the device. The device can be set in the Reset state either by pulling the external RESET pin low, or issuing the AVR_RESET instruction with appropriate setting of the Reset Data Register.

The EXTEST instruction is used for sampling external pins and loading output pins with data. The data from the output latch will be driven out on the pins as soon as the EXTEST instruction is loaded into the JTAG IR-register. Therefore, the SAMPLE/PRELOAD should also be used for setting initial values to the scan ring, to avoid damaging the board when issuing the EXTEST instruction for the first time. SAMPLE/PRELOAD can also be used for taking a snapshot of the external pins during normal operation of the part.

The JTAGEN fuse must be programmed and the JTD bit in the I/O register MCUCSR must be cleared to enable the JTAG Test Access Port.

When using the JTAG interface for Boundary-scan, using a JTAG TCK clock frequency higher than the internal chip frequency is possible. The chip clock is not required to run.

Data Registers

The data registers relevant for Boundary-scan operations are:

- Bypass Register
- Device Identification Register
- Reset Register
- Boundary-scan Chain

Bypass Register

The Bypass Register consists of a single Shift Register stage. When the Bypass Register is selected as path between TDI and TDO, the register is reset to 0 when leaving the Capture-DR controller state. The Bypass Register can be used to shorten the scan chain on a system when the other devices are to be tested.

Device Identification Register

Figure 122 shows the structure of the Device Identification Register.

Figure 122. The Format of the Device Identification Register



Version

Version is a 4-bit number identifying the revision of the component. The JTAG version number follows the revision of the device, and wraps around at revision P (0xF). Revision A and Q is 0x0, revision B and R is 0x1 and so on.

Part Number

The part number is a 16-bit code identifying the component. The JTAG Part Number for Atmel® AVR® ATmega128 is listed in Table 100.

Table 100. AVR JTAG Part Number

| Part Number | JTAG Part Number (Hex) |
|-------------|------------------------|
| ATmega128 | 0x9702 |

Manufacturer ID

The Manufacturer ID is a 11-bit code identifying the manufacturer. The JTAG manufacturer ID for ATMEL is listed in Table 101.

Table 101. Manufacturer ID

| Manufacturer | JTAG Manufacturer ID (Hex) |
|--------------|----------------------------|
| ATMEL | 0x01F |

Reset Register

The Reset Register is a Test Data Register used to reset the part. Since the AVR tri-states Port Pins when reset, the Reset Register can also replace the function of the unimplemented optional JTAG instruction HIGHZ.

A high value in the Reset Register corresponds to pulling the External Reset low. The part is reset as long as there is a high value present in the Reset Register. Depending on the Fuse settings for the clock options, the part will remain reset for a Reset Time-Out Period (refer to “Clock Sources” on page 36) after releasing the Reset Register. The output from this Data Register is not latched, so the Reset will take place immediately, as shown in Figure 123.

Figure 123. Reset Register



Boundary-scan Chain

The Boundary-scan Chain has the capability of driving and observing the logic levels on the digital I/O pins, as well as the boundary between digital and analog logic for analog circuitry having off-chip connections.

See [“Boundary-scan Chain” on page 255](#) for a complete description.

Boundary-scan Specific JTAG Instructions

The Instruction Register is 4-bit wide, supporting up to 16 instructions. Listed below are the JTAG instructions useful for Boundary-scan operation. Note that the optional HIGHZ instruction is not implemented, but all outputs with tri-state capability can be set in high-impedant state by using the AVR_RESET instruction, since the initial state for all port pins is tri-state.

As a definition in this data sheet, the LSB is shifted in and out first for all Shift Registers.

The OPCODE for each instruction is shown behind the instruction name in hex format. The text describes which data register is selected as path between TDI and TDO for each instruction.

EXTEST; \$0

Mandatory JTAG instruction for selecting the Boundary-scan Chain as Data Register for testing circuitry external to the AVR package. For port-pins, Pull-up Disable, Output Control, Output Data, and Input Data are all accessible in the scan chain. For Analog circuits having off-chip connections, the interface between the analog and the digital logic is in the scan chain. The contents of the latched outputs of the Boundary-scan chain is driven out as soon as the JTAG IR-register is loaded with the EXTEST instruction.

The active states are:

- Capture-DR: Data on the external pins are sampled into the Boundary-scan Chain.
- Shift-DR: The Internal Scan Chain is shifted by the TCK input.
- Update-DR: Data from the scan chain is applied to output pins.

IDCODE; \$1

Optional JTAG instruction selecting the 32-bit ID Register as Data Register. The ID Register consists of a version number, a device number and the manufacturer code chosen by JEDEC. This is the default instruction after power-up.

The active states are:

- Capture-DR: Data in the IDCODE Register is sampled into the Boundary-scan Chain.
- Shift-DR: The IDCODE scan chain is shifted by the TCK input.

SAMPLE_PRELOAD; \$2

Mandatory JTAG instruction for pre-loading the output latches and taking a snap-shot of the input/output pins without affecting the system operation. However, the output latched are not connected to the pins. The Boundary-scan Chain is selected as Data Register.

The active states are:

- Capture-DR: Data on the external pins are sampled into the Boundary-scan Chain.
- Shift-DR: The Boundary-scan Chain is shifted by the TCK input.
- Update-DR: Data from the Boundary-scan Chain is applied to the output latches. However, the output latches are not connected to the pins.

AVR_RESET; \$C

The AVR specific public JTAG instruction for forcing the AVR device into the Reset mode or releasing the JTAG Reset source. The TAP controller is not reset by this instruction. The one bit Reset Register is selected as Data Register. Note that the Reset will be active as long as there is a logic 'one' in the Reset Chain. The output from this chain is not latched.

The active states are:

- Shift-DR: The Reset Register is shifted by the TCK input.

BYPASS; \$F

Mandatory JTAG instruction selecting the Bypass Register for Data Register.

The active states are:

- Capture-DR: Loads a logic "0" into the Bypass Register.
- Shift-DR: The Bypass Register cell between TDI and TDO is shifted.

Boundary-scan Related Register in I/O Memory

MCU Control and Status Register – MCUCSR

The MCU Control and Status Register contains control bits for general MCU functions, and provides information on which reset source caused an MCU Reset.

| Bit | 7 | 6 | 5 | 4 | 3 | 2 | 1 | 0 | |
|---------------|-----|---|---|------|------|------|-------|------|---------------------|
| | JTD | – | – | JTRF | WDRF | BORF | EXTRF | PORF | MCUCSR |
| Read/Write | R/W | R | R | R/W | R/W | R/W | R/W | R/W | |
| Initial Value | 0 | 0 | 0 | | | | | | See Bit Description |

• Bit 7 – JTD: JTAG Interface Disable

When this bit is zero, the JTAG interface is enabled if the JTAGEN fuse is programmed. If this bit is one, the JTAG interface is disabled. In order to avoid unintentional disabling or enabling of the JTAG interface, a timed sequence must be followed when changing this bit: The application software must write this bit to the desired value twice within four cycles to change its value.

If the JTAG interface is left unconnected to other JTAG circuitry, the JTD bit should be set to one. The reason for this is to avoid static current at the TDO pin in the JTAG interface.

• Bit 4 – JTRF: JTAG Reset Flag

This bit is set if a Reset is being caused by a logic one in the JTAG Reset Register selected by the JTAG instruction AVR_RESET. This bit is reset by a Power-on Reset, or by writing a logic zero to the flag.

Boundary-scan Chain

The Boundary-scan chain has the capability of driving and observing the logic levels on the digital I/O pins, as well as the boundary between digital and analog logic for analog circuitry having off-chip connection.

Scanning the Digital Port Pins

Figure 124 shows the Boundary-scan Cell for a bi-directional port pin with pull-up function. The cell consists of a standard Boundary-scan cell for the Pull-up Enable – PUE_{xn} – function, and a bi-directional pin cell that combines the three signals Output Control – OC_{xn}, Output Data – OD_{xn}, and Input Data – ID_{xn}, into only a two-stage Shift Register. The port and pin indexes are not used in the following description

The Boundary-scan logic is not included in the figures in the Data Sheet. Figure 125 shows a simple digital Port Pin as described in the section “I/O Ports” on page 65. The Boundary-scan details from Figure 124 replaces the dashed box in Figure 125.

When no alternate port function is present, the Input Data – ID corresponds to the PIN_{xn} Register value (but ID has no synchronizer), Output Data corresponds to the PORT Register, Output Control corresponds to the Data Direction – DD Register, and the Pull-up Enable – PUE_{xn} – corresponds to logic expression $\overline{PUD} \cdot \overline{DDxn} \cdot PORTxn$.

Digital alternate port functions are connected outside the dotted box in Figure 125 to make the scan chain read the actual pin value. For Analog function, there is a direct connection from the external pin to the analog circuit, and a scan chain is inserted on the interface between the digital logic and the analog circuitry.

Figure 124. Boundary-scan Cell for Bi-directional Port Pin with Pull-Up Function.



Figure 125. General Port Pin Schematic diagram

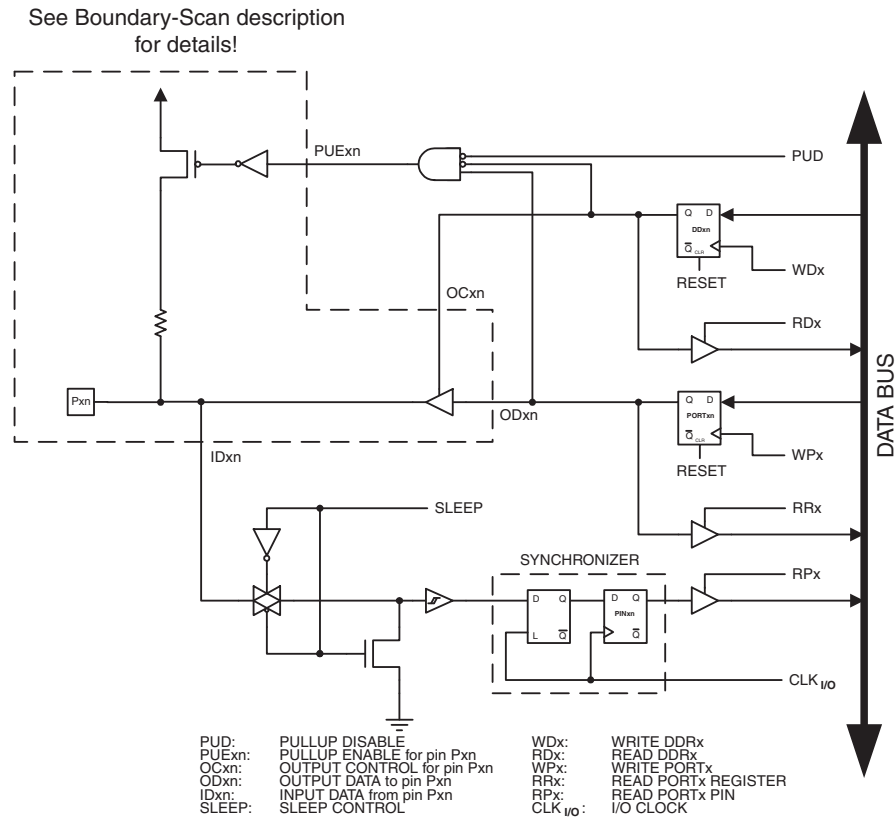

Boundary-scan and the Two-wire Interface

The two Two-wire Interface pins SCL and SDA have one additional control signal in the scan-chain; Two-wire Interface Enable – TWIEN. As shown in [Figure 126](#), the TWIEN signal enables a tri-state buffer with slew-rate control in parallel with the ordinary digital port pins. A general scan cell as shown in [Figure 130](#) is attached to the TWIEN signal.

- Notes:
1. A separate scan chain for the 50 ns spike filter on the input is not provided. The ordinary scan support for digital port pins suffice for connectivity tests. The only reason for having TWIEN in the scan path, is to be able to disconnect the slew-rate control buffer when doing boundary-scan.
 2. Make sure the OC and TWIEN signals are not asserted simultaneously, as this will lead to drive contention.

Figure 126. Additional Scan Signal for the Two-wire Interface



Scanning the RESET Pin

The RESET pin accepts 5V active low logic for standard Reset operation, and 12V active high logic for High Voltage Parallel programming. An observe-only cell as shown in [Figure 127](#) is inserted both for the 5V Reset signal; RSTT, and the 12V Reset signal; RSTHV.

Figure 127. Observe-only Cell



Scanning the Clock Pins

The Atmel® AVR® devices have many clock options selectable by fuses. These are: Internal RC Oscillator, External RC, External Clock, (High Frequency) Crystal Oscillator, Low-frequency Crystal Oscillator, and Ceramic Resonator.

[Figure 128](#) shows how each Oscillator with external connection is supported in the scan chain. The Enable signal is supported with a general boundary-scan cell, while the Oscillator/Clock output is attached to an observe-only cell. In addition to the main clock, the Timer Oscillator is scanned in the same way. The output from the internal RC Oscillator is not scanned, as this Oscillator does not have external connections.

Figure 128. Boundary-scan Cells for Oscillators and Clock Options



Table 102 summarizes the scan registers for the external clock pin XTAL1, oscillators with XTAL1/XTAL2 connections as well as 32kHz Timer Oscillator.

Table 102. Scan Signals for the Oscillators⁽¹⁾⁽²⁾⁽³⁾

| Enable signal | Scanned Clock Line | Clock Option | Scanned Clock Line when not Used |
|---------------|--------------------|--|----------------------------------|
| EXTCLKEN | EXTCLK (XTAL1) | External Clock | 0 |
| OSCON | OSCCK | External Crystal External Ceramic Resonator | 0 |
| RCOSCEN | RCCK | External RC | 1 |
| OSC32EN | OSC32CK | Low Freq. External Crystal | 0 |
| TOSKON | TOSCK | 32kHz Timer Oscillator | 0 |

- Notes:
1. Do not enable more than one clock source as main clock at a time.
 2. Scanning an Oscillator output gives unpredictable results as there is a frequency drift between the Internal Oscillator and the JTAG TCK clock. If possible, scanning an external clock is preferred.
 3. The clock configuration is programmed by fuses. As a fuse is not changed run-time, the clock configuration is considered fixed for a given application. The user is advised to scan the same clock option as to be used in the final system. The enable signals are supported in the scan chain because the system logic can disable clock options in sleep modes, thereby disconnecting the Oscillator pins from the scan path if not provided. The INTCAP fuses are not supported in the scan-chain, so the boundary scan chain can not make a XTAL Oscillator requiring internal capacitors to run unless the fuse is correctly programmed.

Scanning the Analog Comparator

The relevant Comparator signals regarding Boundary-scan are shown in Figure 129. The Boundary-scan cell from Figure 130 is attached to each of these signals. The signals are described in Table 103.

The Comparator need not be used for pure connectivity testing, since all analog inputs are shared with a digital port pin as well.

Table 103. Boundary-scan Signals for the Analog Comparator

| Signal Name | Direction as Seen from the Comparator | Description | Recommended Input when not in Use | Output values when Recommended Inputs are Used |
|-------------|---------------------------------------|---|--|--|
| AC_IDLE | Input | Turns off Analog comparator when true | 1 | Depends upon μ C code being executed |
| ACO | Output | Analog Comparator Output | Will become input to μ C code being executed | 0 |
| ACME | Input | Uses output signal from ADC mux when true | 0 | Depends upon μ C code being executed |
| ACBG | Input | Bandgap Reference enable | 0 | Depends upon μ C code being executed |

Scanning the ADC

Figure 131 shows a block diagram of the ADC with all relevant control and observe signals. The Boundary-scan cell from Figure 127 is attached to each of these signals. The ADC need not be used for pure connectivity testing, since all analog inputs are shared with a digital port pin as well.

Figure 131. Analog to Digital Converter

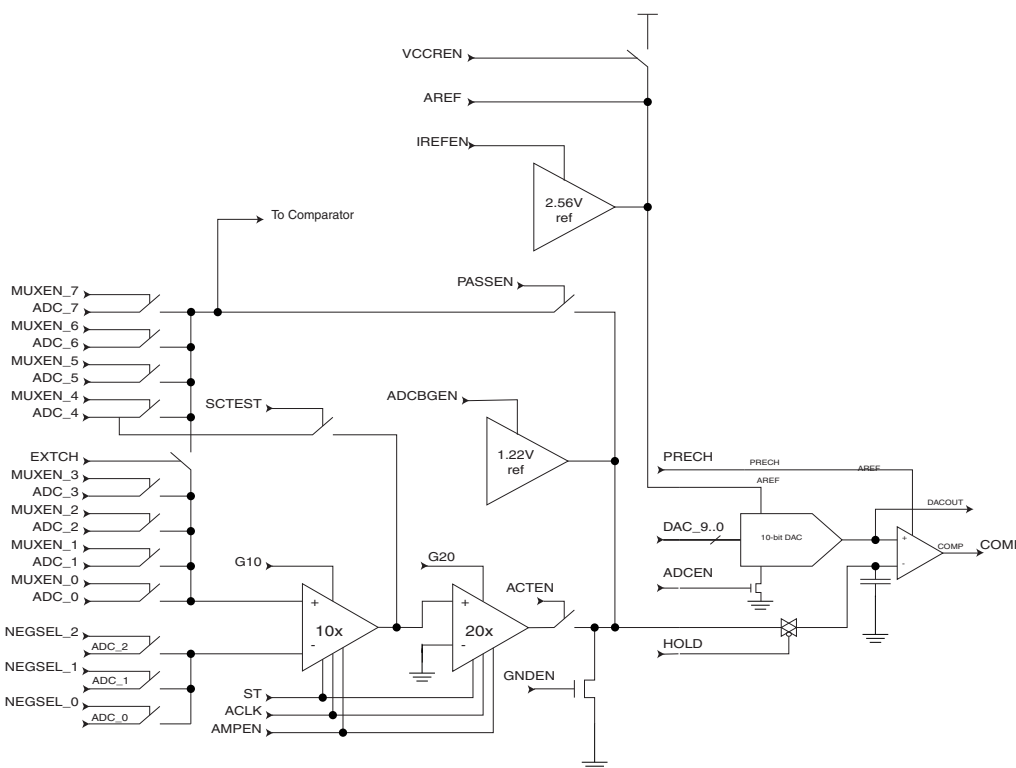

The signals are described briefly in Table 104.

Table 104. Boundary-scan Signals for the ADC

| Signal Name | Direction as Seen from the ADC | Description | Recommended Input when not in Use | Output Values when Recommended Inputs are Used, and CPU is not Using the ADC |
|-------------|--------------------------------|--|-----------------------------------|--|
| COMP | Output | Comparator Output | 0 | 0 |
| ACLK | Input | Clock signal to gain stages implemented as Switch-cap filters | 0 | 0 |
| ACTEN | Input | Enable path from gain stages to the comparator | 0 | 0 |
| ADCBGEN | Input | Enable Band-gap reference as negative input to comparator | 0 | 0 |
| ADCEN | Input | Power-on signal to the ADC | 0 | 0 |
| AMPEN | Input | Power-on signal to the gain stages | 0 | 0 |
| DAC_9 | Input | Bit 9 of digital value to DAC | 1 | 1 |
| DAC_8 | Input | Bit 8 of digital value to DAC | 0 | 0 |
| DAC_7 | Input | Bit 7 of digital value to DAC | 0 | 0 |
| DAC_6 | Input | Bit 6 of digital value to DAC | 0 | 0 |
| DAC_5 | Input | Bit 5 of digital value to DAC | 0 | 0 |
| DAC_4 | Input | Bit 4 of digital value to DAC | 0 | 0 |
| DAC_3 | Input | Bit 3 of digital value to DAC | 0 | 0 |
| DAC_2 | Input | Bit 2 of digital value to DAC | 0 | 0 |
| DAC_1 | Input | Bit 1 of digital value to DAC | 0 | 0 |
| DAC_0 | Input | Bit 0 of digital value to DAC | 0 | 0 |
| EXTCH | Input | Connect ADC channels 0 - 3 to by-pass path around gain stages | 1 | 1 |
| G10 | Input | Enable 10x gain | 0 | 0 |
| G20 | Input | Enable 20x gain | 0 | 0 |
| GNDEN | Input | Ground the negative input to comparator when true | 0 | 0 |
| HOLD | Input | Sample & Hold signal. Sample analog signal when low. Hold signal when high. If gain stages are used, this signal must go active when ACLK is high. | 1 | 1 |
| IREFEN | Input | Enables Band-gap reference as AREF signal to DAC | 0 | 0 |

Table 104. Boundary-scan Signals for the ADC (Continued)

| Signal Name | Direction as Seen from the ADC | Description | Recommended Input when not in Use | Output Values when Recommended Inputs are Used, and CPU is not Using the ADC |
|-------------|--------------------------------|---|-----------------------------------|--|
| MUXEN_7 | Input | Input Mux bit 7 | 0 | 0 |
| MUXEN_6 | Input | Input Mux bit 6 | 0 | 0 |
| MUXEN_5 | Input | Input Mux bit 5 | 0 | 0 |
| MUXEN_4 | Input | Input Mux bit 4 | 0 | 0 |
| MUXEN_3 | Input | Input Mux bit 3 | 0 | 0 |
| MUXEN_2 | Input | Input Mux bit 2 | 0 | 0 |
| MUXEN_1 | Input | Input Mux bit 1 | 0 | 0 |
| MUXEN_0 | Input | Input Mux bit 0 | 1 | 1 |
| NEGSEL_2 | Input | Input Mux for negative input for differential signal, bit 2 | 0 | 0 |
| NEGSEL_1 | Input | Input Mux for negative input for differential signal, bit 1 | 0 | 0 |
| NEGSEL_0 | Input | Input Mux for negative input for differential signal, bit 0 | 0 | 0 |
| PASSEN | Input | Enable pass-gate of gain stages. | 1 | 1 |
| PRECH | Input | Precharge output latch of comparator. (Active low) | 1 | 1 |
| SCTEST | Input | Switch-cap TEST enable. Output from x10 gain stage send out to Port Pin having ADC_4 | 0 | 0 |
| ST | Input | Output of gain stages will settle faster if this signal is high first two ACLK periods after AMPEN goes high. | 0 | 0 |
| VCCREN | Input | Selects Vcc as the ACC reference voltage. | 0 | 0 |

Note: Incorrect setting of the switches in [Figure 131](#) will make signal contention and may damage the part. There are several input choices to the S&H circuitry on the negative input of the output comparator in [Figure 131](#). Make sure only one path is selected from either one ADC pin, Bandgap reference source, or Ground.

If the ADC is not to be used during scan, the recommended input values from [Table 104](#) should be used. The user is recommended **not** to use the Differential Gain stages during scan. Switch-Cap based gain stages require fast operation and accurate timing which is difficult to obtain when used in a scan chain. Details concerning operations of the differential gain stage is therefore not provided.

The Atmel® AVR® ADC is based on the analog circuitry shown in [Figure 131](#) with a successive approximation algorithm implemented in the digital logic. When used in Boundary-scan, the problem is usually to ensure that an applied analog voltage is measured within some limits. This can easily be done without running a successive approximation algorithm: apply the lower limit on the digital DAC[9:0] lines, make sure the output from the comparator is low, then apply the upper limit on the digital DAC[9:0] lines, and verify the output from the comparator to be high.

The ADC need not be used for pure connectivity testing, since all analog inputs are shared with a digital port pin as well.

When using the ADC, remember the following

- The Port Pin for the ADC channel in use must be configured to be an input with pull-up disabled to avoid signal contention.
- In normal mode, a dummy conversion (consisting of 10 comparisons) is performed when enabling the ADC. The user is advised to wait at least 200ns after enabling the ADC before controlling/observing any ADC signal, or perform a dummy conversion before using the first result.
- The DAC values must be stable at the midpoint value 0x200 when having the HOLD signal low (Sample mode).

As an example, consider the task of verifying a 1.5V ±5% input signal at ADC channel 3 when the power supply is 5.0V and AREF is externally connected to V_{CC}.

$$\begin{aligned} \text{The lower limit is: } & \lceil 1024 \cdot 1.5V \cdot 0.95/5V \rceil = 291 = 0x123 \\ \text{The upper limit is: } & \lceil 1024 \cdot 1.5V \cdot 1.05/5V \rceil = 323 = 0x143 \end{aligned}$$

The recommended values from [Table 104](#) are used unless other values are given in the algorithm in [Table 105](#). Only the DAC and Port Pin values of the Scan Chain are shown. The column “Actions” describes what JTAG instruction to be used before filling the Boundary-scan Register with the succeeding columns. The verification should be done on the data scanned out when scanning in the data on the same row in the table.

Table 105. Algorithm for Using the ADC

| Step | Actions | ADCEN | DAC | MUXEN | HOLD | PRECH | PA3. Data | PA3. Control | PA3. Pullup_ Enable |
|------|---|-------|-------|-------|------|-------|-----------|--------------|---------------------|
| 1 | SAMPLE_PRELOAD | 1 | 0x200 | 0x08 | 1 | 1 | 0 | 0 | 0 |
| 2 | EXTEST | 1 | 0x200 | 0x08 | 0 | 1 | 0 | 0 | 0 |
| 3 | | 1 | 0x200 | 0x08 | 1 | 1 | 0 | 0 | 0 |
| 4 | | 1 | 0x123 | 0x08 | 1 | 1 | 0 | 0 | 0 |
| 5 | | 1 | 0x123 | 0x08 | 1 | 0 | 0 | 0 | 0 |
| 6 | Verify the COMP bit scanned out to be 0 | 1 | 0x200 | 0x08 | 1 | 1 | 0 | 0 | 0 |
| 7 | | 1 | 0x200 | 0x08 | 0 | 1 | 0 | 0 | 0 |
| 8 | | 1 | 0x200 | 0x08 | 1 | 1 | 0 | 0 | 0 |

Table 105. Algorithm for Using the ADC

| Step | Actions | ADCEN | DAC | MUXEN | HOLD | PRECH | PA3. Data | PA3. Control | PA3. Pullup_ Enable |
|------|---|-------|-------|-------|------|-------|-----------|--------------|---------------------|
| 9 | | 1 | 0x143 | 0x08 | 1 | 1 | 0 | 0 | 0 |
| 10 | | 1 | 0x143 | 0x08 | 1 | 0 | 0 | 0 | 0 |
| 11 | Verify the COMP bit scanned out to be 1 | 1 | 0x200 | 0x08 | 1 | 1 | 0 | 0 | 0 |

Using this algorithm, the timing constraint on the HOLD signal constrains the TCK clock frequency. As the algorithm keeps HOLD high for five steps, the TCK clock frequency has to be at least five times the number of scan bits divided by the maximum hold time, $t_{hold,max}$

ATmega128 Boundary-scan Order

Table 106 shows the Scan order between TDI and TDO when the Boundary-scan Chain is selected as data path. Bit 0 is the LSB; the first bit scanned in, and the first bit scanned out. The scan order follows the pin-out order as far as possible. Therefore, the bits of Port A is scanned in the opposite bit order of the other ports. Exceptions from the rules are the Scan chains for the analog circuits, which constitute the most significant bits of the scan chain regardless of which physical pin they are connected to. In Figure 124, PXn. Data corresponds to FF0, PXn. Control corresponds to FF1, and PXn. Pullup_enable corresponds to FF2. Bit 2, 3, 4, and 5 of Port C is not in the scan chain, since these pins constitute the TAP pins when the JTAG is enabled.

Table 106. ATmega128 Boundary-scan Order

| Bit Number | Signal Name | Module |
|------------|--------------------------------|------------|
| 204 | AC_IDLE | Comparator |
| 203 | ACO | |
| 202 | ACME | |
| 201 | AINBG | |
| 200 | COMP | ADC |
| 199 | PRIVATE_SIGNAL1 ⁽¹⁾ | |
| 198 | ACLK | |
| 197 | ACTEN | |
| 196 | PRIVATE_SIGNAL1 ⁽²⁾ | |
| 195 | ADCBGEN | |
| 194 | ADCEN | |
| 193 | AMPEN | |
| 192 | DAC_9 | |
| 191 | DAC_8 | |
| 190 | DAC_7 | |
| 189 | DAC_6 | |
| 188 | DAC_5 | |
| 187 | DAC_4 | |
| 186 | DAC_3 | |
| 185 | DAC_2 | |
| 184 | DAC_1 | |
| 183 | DAC_0 | |
| 182 | EXTCH | |
| 181 | G10 | |
| 180 | G20 | |
| 179 | GNDEN | |
| 178 | HOLD | |
| 177 | IREFEN | |
| 176 | MUXEN_7 | |

Table 106. ATmega128 Boundary-scan Order (Continued)

| Bit Number | Signal Name | Module |
|------------|-------------------|--------|
| 175 | MUXEN_6 | ADC |
| 174 | MUXEN_5 | |
| 173 | MUXEN_4 | |
| 172 | MUXEN_3 | |
| 171 | MUXEN_2 | |
| 170 | MUXEN_1 | |
| 169 | MUXEN_0 | |
| 168 | NEGSEL_2 | |
| 167 | NEGSEL_1 | |
| 166 | NEGSEL_0 | |
| 165 | PASSEN | |
| 164 | PRECH | |
| 163 | SCTEST | |
| 162 | ST | |
| 161 | VCCREN | |
| 160 | PEN | |
| 159 | PE0.Data | Port E |
| 158 | PE0.Control | |
| 157 | PE0.Pullup_Enable | |
| 156 | PE1.Data | |
| 155 | PE1.Control | |
| 154 | PE1.Pullup_Enable | |
| 153 | PE2.Data | |
| 152 | PE2.Control | |
| 151 | PE2.Pullup_Enable | |
| 150 | PE3.Data | |
| 149 | PE3.Control | |
| 148 | PE3.Pullup_Enable | |
| 147 | PE4.Data | |
| 146 | PE4.Control | |
| 145 | PE4.Pullup_Enable | |
| 144 | PE5.Data | |
| 143 | PE5.Control | |
| 142 | PE5.Pullup_Enable | |
| 141 | PE6.Data | |
| 140 | PE6.Control | |

Table 106. ATmega128 Boundary-scan Order (Continued)

| Bit Number | Signal Name | Module |
|------------|-------------------|------------------------|
| 139 | PE6.Pullup_Enable | Port E |
| 138 | PE7.Data | |
| 137 | PE7.Control | |
| 136 | PE7.Pullup_Enable | |
| 135 | PB0.Data | Port B |
| 134 | PB0.Control | |
| 133 | PB0.Pullup_Enable | |
| 132 | PB1.Data | |
| 131 | PB1.Control | |
| 130 | PB1.Pullup_Enable | |
| 129 | PB2.Data | |
| 128 | PB2.Control | |
| 127 | PB2.Pullup_Enable | |
| 126 | PB3.Data | |
| 125 | PB3.Control | |
| 124 | PB3.Pullup_Enable | |
| 123 | PB4.Data | |
| 122 | PB4.Control | |
| 121 | PB4.Pullup_Enable | |
| 120 | PB5.Data | |
| 119 | PB5.Control | |
| 118 | PB5.Pullup_Enable | |
| 117 | PB6.Data | |
| 116 | PB6.Control | |
| 115 | PB6.Pullup_Enable | |
| 114 | PB7.Data | |
| 113 | PB7.Control | |
| 112 | PB7.Pullup_Enable | |
| 111 | PG3.Data | Port G |
| 110 | PG3.Control | |
| 109 | PG3.Pullup_Enable | |
| 108 | PG4.Data | |
| 107 | PG4.Control | |
| 106 | PG4.Pullup_Enable | |
| 105 | TOSC | 32kHz Timer Oscillator |
| 104 | TOSCON | |

Table 106. ATmega128 Boundary-scan Order (Continued)

| Bit Number | Signal Name | Module |
|------------|-------------------|--|
| 103 | RSTT | Reset Logic (Observe-only) |
| 102 | RSTHV | |
| 101 | EXTCLKEN | Enable signals for main Clock/Oscillators |
| 100 | OSCON | |
| 99 | RCOSCEN | |
| 98 | OSC32EN | |
| 97 | EXTCLK (XTAL1) | Clock input and Oscillators for the main clock (Observe-only) |
| 96 | OSCCK | |
| 95 | RCCK | |
| 94 | OSC32CK | |
| 93 | TWIEN | TWI |
| 92 | PD0.Data | Port D |
| 91 | PD0.Control | |
| 90 | PD0.Pullup_Enable | |
| 89 | PD1.Data | |
| 88 | PD1.Control | |
| 87 | PD1.Pullup_Enable | |
| 86 | PD2.Data | |
| 85 | PD2.Control | |
| 84 | PD2.Pullup_Enable | |
| 83 | PD3.Data | |
| 82 | PD3.Control | |
| 81 | PD3.Pullup_Enable | |
| 80 | PD4.Data | |
| 79 | PD4.Control | |
| 78 | PD4.Pullup_Enable | |
| 77 | PD5.Data | |
| 76 | PD5.Control | |
| 75 | PD5.Pullup_Enable | |
| 74 | PD6.Data | |
| 73 | PD6.Control | |
| 72 | PD6.Pullup_Enable | |
| 71 | PD7.Data | |
| 70 | PD7.Control | |
| 69 | PD7.Pullup_Enable | |
| 68 | PG0.Data | Port G |

Table 106. ATmega128 Boundary-scan Order (Continued)

| Bit Number | Signal Name | Module |
|------------|-------------------|--------|
| 67 | PG0.Control | Port G |
| 66 | PG0.Pullup_Enable | |
| 65 | PG1.Data | |
| 64 | PG1.Control | |
| 63 | PG1.Pullup_Enable | |
| 62 | PC0.Data | Port C |
| 61 | PC0.Control | |
| 60 | PC0.Pullup_Enable | |
| 59 | PC1.Data | |
| 58 | PC1.Control | |
| 57 | PC1.Pullup_Enable | |
| 56 | PC2.Data | |
| 55 | PC2.Control | |
| 54 | PC2.Pullup_Enable | |
| 53 | PC3.Data | |
| 52 | PC3.Control | |
| 51 | PC3.Pullup_Enable | |
| 50 | PC4.Data | |
| 49 | PC4.Control | |
| 48 | PC4.Pullup_Enable | |
| 47 | PC5.Data | |
| 46 | PC5.Control | |
| 45 | PC5.Pullup_Enable | |
| 44 | PC6.Data | |
| 43 | PC6.Control | |
| 42 | PC6.Pullup_Enable | |
| 41 | PC7.Data | |
| 40 | PC7.Control | |
| 39 | PC7.Pullup_Enable | |
| 38 | PG2.Data | Port G |
| 37 | PG2.Control | |
| 36 | PG2.Pullup_Enable | |
| 35 | PA7.Data | Port A |
| 34 | PA7.Control | |
| 33 | PA7.Pullup_Enable | |
| 32 | PA6.Data | |

Table 106. ATmega128 Boundary-scan Order (Continued)

| Bit Number | Signal Name | Module |
|------------|-------------------|--------|
| 31 | PA6.Control | Port A |
| 30 | PA6.Pullup_Enable | |
| 29 | PA5.Data | |
| 28 | PA5.Control | |
| 27 | PA5.Pullup_Enable | |
| 26 | PA4.Data | |
| 25 | PA4.Control | |
| 24 | PA4.Pullup_Enable | |
| 23 | PA3.Data | |
| 22 | PA3.Control | |
| 21 | PA3.Pullup_Enable | |
| 20 | PA2.Data | |
| 19 | PA2.Control | |
| 18 | PA2.Pullup_Enable | |
| 17 | PA1.Data | |
| 16 | PA1.Control | |
| 15 | PA1.Pullup_Enable | |
| 14 | PA0.Data | |
| 13 | PA0.Control | |
| 12 | PA0.Pullup_Enable | |
| 11 | PF3.Data | Port F |
| 10 | PF3.Control | |
| 9 | PF3.Pullup_Enable | |
| 8 | PF2.Data | |
| 7 | PF2.Control | |
| 6 | PF2.Pullup_Enable | |
| 5 | PF1.Data | |
| 4 | PF1.Control | |
| 3 | PF1.Pullup_Enable | |
| 2 | PF0.Data | |
| 1 | PF0.Control | |
| 0 | PF0.Pullup_Enable | |

Notes: 1. PRIVATE_SIGNAL1 should always scanned in as zero.
 2. PRIVATE_SIGNAL2 should always scanned in as zero.

**Boundary-scan
Description
Language Files**

Boundary-scan Description Language (BSDL) files describe Boundary-scan capable devices in a standard format used by automated test-generation software. The order and function of bits in the Boundary-scan Data Register are included in this description.

Boot Loader Support – Read-While-Write Self-Programming

The Boot Loader Support provides a real Read-While-Write Self-Programming mechanism for downloading and uploading program code by the MCU itself. This feature allows flexible application software updates controlled by the MCU using a Flash-resident Boot Loader program. The Boot Loader program can use any available data interface and associated protocol to read code and write (program) that code into the Flash memory, or read the code from the program memory. The program code within the Boot Loader section has the capability to write into the entire Flash, including the Boot Loader memory. The Boot Loader can thus even modify itself, and it can also erase itself from the code if the feature is not needed anymore. The size of the Boot Loader memory is configurable with fuses and the Boot Loader has two separate sets of Boot Lock bits which can be set independently. This gives the user a unique flexibility to select different levels of protection.

Boot Loader Features

- **Read-While-Write Self-Programming**
- **Flexible Boot Memory Size**
- **High Security (Separate Boot Lock Bits for a Flexible Protection)**
- **Separate Fuse to Select Reset Vector**
- **Optimized Page⁽¹⁾ Size**
- **Code Efficient Algorithm**
- **Efficient Read-Modify-Write Support**

Note: 1. A page is a section in the flash consisting of several bytes (see [Table 123 on page 291](#)) used during programming. The page organization does not affect normal operation.

Application and Boot Loader Flash Sections

The Flash memory is organized in two main sections, the Application section and the Boot Loader section (see [Figure 133](#)). The size of the different sections is configured by the BOOTSZ fuses as shown in [Table on page 284](#) and [Figure 133](#). These two sections can have different level of protection since they have different sets of Lock bits.

Application Section

The application section is the section of the Flash that is used for storing the application code. The protection level for the application section can be selected by the application Boot Lock bits (Boot Lock bits 0), see [Table on page 275](#). The application section can never store any Boot Loader code since the SPM instruction is disabled when executed from the application section.

Boot Loader Section – BLS

While the application section is used for storing the application code, the The Boot Loader software must be located in the BLS since the SPM instruction can initiate a programming when executing from the BLS only. The SPM instruction can access the entire Flash, including the BLS itself. The protection level for the Boot Loader section can be selected by the Boot Loader Lock bits (Boot Lock bits 1), see [Table 109 on page 276](#).

Read-While-Write and No Read-While-Write Flash Sections

Whether the CPU supports Read-While-Write or if the CPU is halted during a Boot Loader software update is dependent on which address that is being programmed. In addition to the two sections that are configurable by the BOOTSZ fuses as described above, the Flash is also divided into two fixed sections, the Read-While-Write (RWW) section and the No Read-While-Write (NRWW) section. The limit between the RWW- and NRWW sections is given in [Table Note: on page 284](#) and [Figure 133 on page 275](#). The main difference between the two sections is:

- When erasing or writing a page located inside the RWW section, the NRWW section can be read during the operation.
- When erasing or writing a page located inside the NRWW section, the CPU is halted during the entire operation.

Note that the user software can never read any code that is located inside the RWW section during a Boot Loader software operation. The syntax “Read-While-Write section” refers to which

section that is being programmed (erased or written), not which section that actually is being read during a Boot Loader software update.

Read-While-Write Section – RWW

If a Boot Loader software update is programming a page inside the RWW section, it is possible to read code from the Flash, but only code that is located in the NRWW section. During an on-going programming, the software must ensure that the RWW section never is being read. If the user software is trying to read code that is located inside the RWW section (i.e., by a call/jmp/lpm or an interrupt) during programming, the software might end up in an unknown state. To avoid this, the interrupts should either be disabled or moved to the Boot Loader Section. The Boot Loader section is always located in the NRWW section. The RWW Section Busy bit (RWWSB) in the Store Program Memory Control and Status Register (SPMCSR) will be read as logical one as long as the RWW section is blocked for reading. After a programming is completed, the RWWSB must be cleared by software before reading code located in the RWW section. See “Store Program Memory Control and Status Register – SPMCSR” on page 277. for details on how to clear RWWSB.

No Read-While-Write Section – NRWW

The code located in the NRWW section can be read when the Boot Loader software is updating a page in the RWW section. When the Boot Loader code updates the NRWW section, the CPU is halted during the entire page erase or page write operation.

Table 107. Read-While-Write Features

| Which Section does the Z-pointer Address During the Programming? | Which Section can be Read During Programming? | Is the CPU Halted? | Read-While-Write Supported? |
|--|---|--------------------|-----------------------------|
| RWW section | NRWW section | No | Yes |
| NRWW section | None | Yes | No |

Figure 132. Read-While-Write vs. No Read-While-Write



Figure 133. Memory Sections⁽¹⁾



Note: 1. The parameters in the figure above are given in [Table on page 284](#).

Boot Loader Lock Bits

If no Boot Loader capability is needed, the entire Flash is available for application code. The Boot Loader has two separate sets of Boot Lock bits which can be set independently. This gives the user a unique flexibility to select different levels of protection.

The user can select:

- To protect the entire Flash from a software update by the MCU
- To protect only the Boot Loader Flash section from a software update by the MCU
- To protect only the Application Flash section from a software update by the MCU
- Allow software update in the entire Flash

See [Table 108](#) and [Table 109](#) for further details. The Boot Lock bits can be set in software and in Serial or Parallel Programming mode, but they can be cleared by a chip erase command only. The general Write Lock (Lock bit mode 2) does not control the programming of the Flash memory by SPM instruction. Similarly, the general Read/Write Lock (Lock bit mode 3) does not control reading nor writing by LPM/SPM, if it is attempted.

Table 108. Boot Lock Bit0 Protection Modes (Application Section)⁽¹⁾

| BLB0 mode | BLB02 | BLB01 | Protection |
|-----------|-------|-------|---|
| 1 | 1 | 1 | No restrictions for SPM or LPM accessing the Application section. |
| 2 | 1 | 0 | SPM is not allowed to write to the Application section. |
| 3 | 0 | 0 | SPM is not allowed to write to the Application section, and LPM executing from the Boot Loader section is not allowed to read from the Application section. If interrupt vectors are placed in the Boot Loader section, interrupts are disabled while executing from the Application section. |
| 4 | 0 | 1 | LPM executing from the Boot Loader section is not allowed to read from the Application section. If interrupt vectors are placed in the Boot Loader section, interrupts are disabled while executing from the Application section. |

Note: 1. “1” means unprogrammed, “0” means programmed

Table 109. Boot Lock Bit1 Protection Modes (Boot Loader Section)⁽¹⁾

| BLB1 mode | BLB12 | BLB1 1 | Protection |
|-----------|-------|--------|---|
| 1 | 1 | 1 | No restrictions for SPM or LPM accessing the Boot Loader section. |
| 2 | 1 | 0 | SPM is not allowed to write to the Boot Loader section. |
| 3 | 0 | 0 | SPM is not allowed to write to the Boot Loader section, and LPM executing from the Application section is not allowed to read from the Boot Loader section. If interrupt vectors are placed in the Application section, interrupts are disabled while executing from the Boot Loader section. |
| 4 | 0 | 1 | LPM executing from the Application section is not allowed to read from the Boot Loader section. If interrupt vectors are placed in the Application section, interrupts are disabled while executing from the Boot Loader section. |

Note: 1. “1” means unprogrammed, “0” means programmed

Entering the Boot Loader Program

Entering the Boot Loader takes place by a jump or call from the application program. This may be initiated by a trigger such as a command received via USART, or SPI interface. Alternatively, the Boot Reset Fuse can be programmed so that the Reset Vector Reset is pointing to the Boot Flash start address after a reset. In this case, the Boot Loader is started after a reset. After the application code is loaded, the program can start executing the application code. Note that the fuses cannot be changed by the MCU itself. This means that once the Boot Reset Fuse is programmed, the Reset Vector will always point to the Boot Loader Reset and the fuse can only be changed through the serial or parallel programming interface.

Table 110. Boot Reset Fuse⁽¹⁾

| BOATRST | Reset Address |
|---------|---|
| 1 | Reset Vector = Application Reset (address \$0000) |
| 0 | Reset Vector = Boot Loader Reset (see Table 112 on page 284) |

Note: 1. “1” means unprogrammed, “0” means programmed

Store Program Memory Control and Status Register – SPMCSR

The Store Program Memory Control and Status Register contains the control bits needed to control the Boot Loader operations.

| Bit | 7 | 6 | 5 | 4 | 3 | 2 | 1 | 0 | |
|---------------|--------------|--------------|---|---------------|---------------|--------------|--------------|--------------|---------------|
| | SPMIE | RWWSB | – | RWWSRE | BLBSET | PGWRT | PGERS | SPMEN | SPMCSR |
| Read/Write | R/W | R | R | R/W | R/W | R/W | R/W | R/W | |
| Initial Value | 0 | 0 | 0 | 0 | 0 | 0 | 0 | 0 | |

- **Bit 7 – SPMIE: SPM Interrupt Enable**

When the SPMIE bit is written to one, and the I-bit in the Status Register is set (one), the SPM ready interrupt will be enabled. The SPM ready Interrupt will be executed as long as the SPMEN bit in the SPMCSR Register is cleared.

- **Bit 6 – RWWSB: Read-While-Write Section Busy**

When a Self-Programming (page erase or page write) operation to the RWW section is initiated, the RWWSB will be set (one) by hardware. When the RWWSB bit is set, the RWW section cannot be accessed. The RWWSB bit will be cleared if the RWWSRE bit is written to one after a self-programming operation is completed. Alternatively the RWWSB bit will automatically be cleared if a page load operation is initiated.

- **Bit 5 – Res: Reserved Bit**

This bit is a reserved bit in the ATmega128 and always read as zero.

- **Bit 4 – RWWSRE: Read-While-Write Section Read Enable**

When Programming (page erase or page write) to the RWW section, the RWW section is blocked for reading (the RWWSB will be set by hardware). To re-enable the RWW section, the user software must wait until the programming is completed (SPMEN will be cleared). Then, if the RWWSRE bit is written to one at the same time as SPMEN, the next SPM instruction within four clock cycles re-enables the RWW section. The RWW section cannot be re-enabled while the Flash is busy with a page erase or a page write (SPMEN is set). If the RWWSRE bit is written while the Flash is being loaded, the Flash load operation will abort and the data loaded will be lost.

- **Bit 3 – BLBSET: Boot Lock Bit Set**

If this bit is written to one at the same time as SPMEN, the next SPM instruction within four clock cycles sets Boot Lock bits, according to the data in R0. The data in R1 and the address in the Z-pointer are ignored. The BLBSET bit will automatically be cleared upon completion of the lock bit set, or if no SPM instruction is executed within four clock cycles.

An LPM instruction within three cycles after BLBSET and SPMEN are set in the SPMCSR Register, will read either the Lock bits or the Fuse bits (depending on Z0 in the Z-pointer) into the destination register. See [“Reading the Fuse and Lock Bits from Software” on page 281](#) for details.

- **Bit 2 – PGWRT: Page Write**

If this bit is written to one at the same time as SPMEN, the next SPM instruction within four clock cycles executes page write, with the data stored in the temporary buffer. The page address is taken from the high part of the Z-pointer. The data in R1 and R0 are ignored. The PGWRT bit will auto-clear upon completion of a page write, or if no SPM instruction is executed within four clock cycles. The CPU is halted during the entire page write operation if the NRWW section is addressed.

- **Bit 1 – PGERS: Page Erase**

If this bit is written to one at the same time as SPMEN, the next SPM instruction within four clock cycles executes page erase. The page address is taken from the high part of the Z-pointer. The data in R1 and R0 are ignored. The PGERS bit will auto-clear upon completion of a page erase,

or if no SPM instruction is executed within four clock cycles. The CPU is halted during the entire page write operation if the NRWW section is addressed.

- **Bit 0 – SPMEN: Store Program Memory Enable**

This bit enables the SPM instruction for the next four clock cycles. If written to one together with either RWWSRE, BLBSET, PGWRT or PGERS, the following SPM instruction will have a special meaning, see description above. If only SPMEN is written, the following SPM instruction will store the value in R1:R0 in the temporary page buffer addressed by the Z-pointer. The LSB of the Z-pointer is ignored. The SPMEN bit will auto-clear upon completion of an SPM instruction, or if no SPM instruction is executed within four clock cycles. During page erase and page write, the SPMEN bit remains high until the operation is completed.

Writing any other combination than “10001”, “01001”, “00101”, “00011” or “00001” in the lower five bits will have no effect.

Addressing the Flash During Self-Programming

The Z-pointer together with RAMPZ are used to address the SPM commands. For details on how to use the RAMPZ, see “RAM Page Z Select Register – RAMPZ” on page 13.

| | | | | | | | | |
|----------|-----|-----|-----|-----|-----|-----|----|----|
| Bit | 15 | 14 | 13 | 12 | 11 | 10 | 9 | 8 |
| ZH (R31) | Z15 | Z14 | Z13 | Z12 | Z11 | Z10 | Z9 | Z8 |
| ZL (R30) | Z7 | Z6 | Z5 | Z4 | Z3 | Z2 | Z1 | Z0 |
| | 7 | 6 | 5 | 4 | 3 | 2 | 1 | 0 |

Since the Flash is organized in pages (see [Table 123 on page 291](#)), the program counter can be treated as having two different sections. One section, consisting of the least significant bits, is addressing the words within a page, while the most significant bits are addressing the pages. This is shown in [Figure 134](#). Note that the page erase and page write operations are addressed independently. Therefore it is of major importance that the Boot Loader software addresses the same page in both the page erase and page write operation. Once a programming operation is initiated, the address is latched and the Z-pointer/RAMPZ can be used for other operations.

The only SPM operation that does not use the Z-pointer/RAMPZ is setting the Boot Loader Lock bits. The content of the Z-pointer/RAMPZ is ignored and will have no effect on the operation. The (E)LPM instruction does also use the Z-pointer/RAMPZ to store the address. Since this instruction addresses the Flash byte by byte, also the LSB (bit Z0) of the Z-pointer is used.

Figure 134. Addressing the Flash During SPM⁽¹⁾



- Notes:
1. The different variables used in [Figure 134](#) are listed in [Table 114](#) on page 285.
 2. PCPAGE and PCWORD are listed in [Table 124](#) on page 291.

Self-Programming the Flash

The program memory is updated in a page by page fashion. Before programming a page with the data stored in the temporary page buffer, the page must be erased. The temporary page buffer is filled one word at a time using SPM and the buffer can be filled either before the page erase command or between a page erase and a page write operation:

Alternative 1, fill the buffer before a page erase

- Fill temporary page buffer
- Perform a page erase
- Perform a page write

Alternative 2, fill the buffer after page erase

- Perform a page erase
- Fill temporary page buffer
- Perform a page write

If only a part of the page needs to be changed, the rest of the page must be stored (for example in the temporary page buffer) before the erase, and then be rewritten. When using alternative 1, the Boot Loader provides an effective Read-Modify-Write feature which allows the user software to first read the page, do the necessary changes, and then write back the modified data. If alternative 2 is used, it is not possible to read the old data while loading since the page is already erased. The temporary page buffer can be accessed in a random sequence. It is essential that the page address used in both the page erase and page write operation is addressing the same page. See [“Simple Assembly Code Example for a Boot Loader”](#) on page 282 for an assembly code example.

Performing Page Erase by SPM

To execute page erase, set up the address in the Z-pointer and RAMPZ, write “X0000011” to SPMCSR and execute SPM within four clock cycles after writing SPMCSR. The data in R1 and R0 is ignored. The page address must be written to PCPAGE in the Z-register. Other bits in the Z-pointer must be written zero during this operation.

- Page Erase to the RWW section: The NRWW section can be read during the page erase.
- Page Erase to the NRWW section: The CPU is halted during the operation.

Filling the Temporary Buffer (Page Loading)

To write an instruction word, set up the address in the Z-pointer and data in R1:R0, write “00000001” to SPMCSR and execute SPM within four clock cycles after writing SPMCSR. The content of PCWORD in the Z-register is used to address the data in the temporary buffer. The temporary buffer will auto-erase after a page write operation or by writing the RWWSRE bit in SPMCSR. It is also erased after a System Reset. Note that it is not possible to write more than one time to each address without erasing the temporary buffer.

Note: If the EEPROM is written in the middle of an SPM Page Load operation, all data loaded will be lost.

Performing a Page Write

To execute page write, set up the address in the Z-pointer and RAMPZ, write “X0000101” to SPMCSR and execute SPM within four clock cycles after writing SPMCSR. The data in R1 and R0 is ignored. The page address must be written to PCPAGE. Other bits in the Z-pointer must be written zero during this operation.

- Page Write to the RWW section: The NRWW section can be read during the page write.
- Page Write to the NRWW section: The CPU is halted during the operation.

Using the SPM Interrupt

If the SPM interrupt is enabled, the SPM interrupt will generate a constant interrupt when the SPMEN bit in SPMCSR is cleared. This means that the interrupt can be used instead of polling the SPMCSR Register in software. When using the SPM interrupt, the interrupt vectors should be moved to the BLS section to avoid that an interrupt is accessing the RWW section when it is blocked for reading. How to move the interrupts is described in [“Interrupts” on page 59](#).

Consideration While Updating BLS

Special care must be taken if the user allows the Boot Loader section to be updated by leaving Boot Lock bit11 unprogrammed. An accidental write to the Boot Loader itself can corrupt the entire Boot Loader, and further software updates might be impossible. If it is not necessary to change the Boot Loader software itself, it is recommended to program the Boot Lock bit11 to protect the Boot Loader software from any internal software changes.

Prevent Reading the RWW Section During Self-Programming

During Self-Programming (either page erase or page write), the RWW section is always blocked for reading. The user software itself must prevent that this section is addressed during the Self-Programming operation. The RWWSB in the SPMCSR will be set as long as the RWW section is busy. During Self-Programming the interrupt vector table should be moved to the BLS as described in [“Interrupts” on page 59](#), or the interrupts must be disabled. Before addressing the RWW section after the programming is completed, the user software must clear the RWWSB by writing the RWWSRE. See [“Simple Assembly Code Example for a Boot Loader” on page 282](#) for an example.

Setting the Boot Loader Lock Bits by SPM

To set the Boot Loader Lock bits, write the desired data to R0, write “X0001001” to SPMCSR and execute SPM within four clock cycles after writing SPMCSR. The only accessible lock bits are the Boot Lock bits that may prevent the Application and Boot Loader section from any software update by the MCU.

| Bit | 7 | 6 | 5 | 4 | 3 | 2 | 1 | 0 |
|-----|---|---|-------|-------|-------|-------|---|---|
| R0 | 1 | 1 | BLB12 | BLB11 | BLB02 | BLB01 | 1 | 1 |

See [Table 108](#) and [Table 109](#) for how the different settings of the Boot Loader Bits affect the Flash access.

If bits 5..2 in R0 are cleared (zero), the corresponding Boot Lock bit will be programmed if an SPM instruction is executed within four cycles after BLBSET and SPMEN are set in SPMCSR. The Z-pointer is don't care during this operation, but for future compatibility it is recommended to load the Z-pointer with \$0001 (same as used for reading the Lock bits). For future compatibility It is also recommended to set bits 7, 6, 1, and 0 in R0 to “1” when writing the lock-bits. When programming the Lock Bits the entire Flash can be read during the operation.

EEPROM Write Prevents Writing to SPMCSR

Note that an EEPROM write operation will block all software programming to Flash. Reading the Fuses and Lock bits from software will also be prevented during the EEPROM write operation. It is recommended that the user checks the status bit (EWE) in the EECR Register and verifies that the bit is cleared before writing to the SPMCSR Register.

Reading the Fuse and Lock Bits from Software

It is possible to read both the Fuse and Lock bits from software. To read the Lock bits, load the Z-pointer with \$0001 and set the BLBSET and SPMEN bits in SPMCSR. When an LPM instruction is executed within three CPU cycles after the BLBSET and SPMEN bits are set in SPMCSR, the value of the Lock bits will be loaded in the destination register. The BLBSET and SPMEN bits will auto-clear upon completion of reading the Lock bits or if no LPM instruction is executed within three CPU cycles or no SPM instruction is executed within four CPU cycles. When BLBSET and SPMEN are cleared, LPM will work as described in the Instruction set Manual.

| Bit | 7 | 6 | 5 | 4 | 3 | 2 | 1 | 0 |
|-----|---|---|-------|-------|-------|-------|-----|-----|
| Rd | - | - | BLB12 | BLB11 | BLB02 | BLB01 | LB2 | LB1 |

The algorithm for reading the Fuse Low bits is similar to the one described above for reading the Lock bits. To read the Fuse Low bits, load the Z-pointer with \$0000 and set the BLBSET and SPMEN bits in SPMCSR. When an LPM instruction is executed within three cycles after the BLBSET and SPMEN bits are set in the SPMCSR, the value of the Fuse Low bits (FLB) will be loaded in the destination register as shown below. Refer to [Table 119 on page 288](#) for a detailed description and mapping of the Fuse Low bits.

| Bit | 7 | 6 | 5 | 4 | 3 | 2 | 1 | 0 |
|-----|------|------|------|------|------|------|------|------|
| Rd | FLB7 | FLB6 | FLB5 | FLB4 | FLB3 | FLB2 | FLB1 | FLB0 |

Similarly, when reading the Fuse High bits, load \$0003 in the Z-pointer. When an LPM instruction is executed within three cycles after the BLBSET and SPMEN bits are set in the SPMCSR, the value of the Fuse High bits (FHB) will be loaded in the destination register as shown below. Refer to [Table 118 on page 288](#) for detailed description and mapping of the Fuse High bits.

| Bit | 7 | 6 | 5 | 4 | 3 | 2 | 1 | 0 |
|-----|------|------|------|------|------|------|------|------|
| Rd | FHB7 | FHB6 | FHB5 | FHB4 | FHB3 | FHB2 | FHB1 | FHB0 |

When reading the Extended Fuse bits, load \$0002 in the Z-pointer. When an LPM instruction is executed within three cycles after the BLBSET and SPMEN bits are set in the SPMCSR, the value of the Extended Fuse bits (EFB) will be loaded in the destination register as shown below. Refer to [Table 117 on page 287](#) for detailed description and mapping of the Fuse High bits.

| Bit | 7 | 6 | 5 | 4 | 3 | 2 | 1 | 0 |
|-----|---|---|---|---|---|---|------|------|
| Rd | - | - | - | - | - | - | EFB1 | EFB0 |

Fuse and Lock bits that are programmed, will be read as zero. Fuse and Lock bits that are unprogrammed, will be read as one.

Preventing Flash Corruption

During periods of low V_{CC} , the Flash program can be corrupted because the supply voltage is too low for the CPU and the Flash to operate properly. These issues are the same as for board level systems using the Flash, and the same design solutions should be applied.

A Flash program corruption can be caused by two situations when the voltage is too low. First, a regular write sequence to the Flash requires a minimum voltage to operate correctly. Secondly, the CPU itself can execute instructions incorrectly, if the supply voltage for executing instructions is too low.

Flash corruption can easily be avoided by following these design recommendations (one is sufficient):

1. If there is no need for a Boot Loader update in the system, program the Boot Loader Lock bits to prevent any Boot Loader software updates.
2. Keep the AVR RESET active (low) during periods of insufficient power supply voltage. This can be done by enabling the internal Brown-out Detector (BOD) if the operating voltage matches the detection level. If not, an external low V_{CC} Reset Protection circuit can be used. If a Reset occurs while a write operation is in progress, the write operation will be completed provided that the power supply voltage is sufficient.
3. Keep the AVR core in Power-down Sleep mode during periods of low V_{CC} . This will prevent the CPU from attempting to decode and execute instructions, effectively protecting the SPMCSR Register and thus the Flash from unintentional writes.

Programming Time for Flash when Using SPM

The calibrated RC Oscillator is used to time Flash accesses. [Table 111](#) shows the typical programming time for Flash accesses from the CPU.

Table 111. SPM Programming Time.

| Symbol | Min Programming Time | Max Programming Time |
|--|----------------------|----------------------|
| Flash write (page erase, page write, and write lock bits by SPM) | 3.7 ms | 4.5 ms |

Simple Assembly Code Example for a Boot Loader

```

;-the routine writes one page of data from RAM to Flash
; the first data location in RAM is pointed to by the Y pointer
; the first data location in Flash is pointed to by the Z-pointer
;-error handling is not included
;-the routine must be placed inside the boot space
; (at least the Do_spm sub routine). Only code inside NRWW section can
; be read during self-programming (page erase and page write).
;-registers used: r0, r1, temp1 (r16), temp2 (r17), looplo (r24),
; loophi (r25), spmcsrval (r20)
; storing and restoring of registers is not included in the routine
; register usage can be optimized at the expense of code size
;-It is assumed that either the interrupt table is moved to the Boot
; loader section or that the interrupts are disabled.
.equ PAGESIZEB = PAGESIZE*2      ;PAGESIZEB is page size in BYTES, not words
.org SMALLBOOTSTART
Write_page:
; page erase
ldi spmcsrval, (1<<PGERS) | (1<<SPMEN)
call Do_spm

; re-enable the RWW section
ldi spmcsrval, (1<<RWWSRE) | (1<<SPMEN)
call Do_spm

```

```

; transfer data from RAM to Flash page buffer
ldi looplo, low(PAGESIZEB);init loop variable
ldi loophi, high(PAGESIZEB);not required for PAGESIZEB<=256
Wrloop:
ld r0, Y+
ld r1, Y+
ldi spmcsrval, (1<<SPMEN)
call Do_spm
adiw ZH:ZL, 2
sbiw loophi:looplo, 2 ;use subi for PAGESIZEB<=256
brne Wrloop

; execute page write
subi ZL, low(PAGESIZEB) ;restore pointer
sbci ZH, high(PAGESIZEB) ;not required for PAGESIZEB<=256
ldi spmcsrval, (1<<PGWRT) | (1<<SPMEN)
call Do_spm

; re-enable the RWW section
ldi spmcsrval, (1<<RWWSRE) | (1<<SPMEN)
call Do_spm

; read back and check, optional
ldi looplo, low(PAGESIZEB);init loop variable
ldi loophi, high(PAGESIZEB);not required for PAGESIZEB<=256
subi YL, low(PAGESIZEB) ;restore pointer
sbci YH, high(PAGESIZEB)
Rdloop:
lpm r0, Z+
ld r1, Y+
cpse r0, r1
jmp Error
sbiw loophi:looplo, 1 ;use subi for PAGESIZEB<=256
brne Rdloop

; return to RWW section
; verify that RWW section is safe to read
Return:
lds temp1, SPMCSR
sbrc temp1, RWWSB ; If RWWSB is set, the RWW section is not ready
yet
ret
; re-enable the RWW section
ldi spmcsrval, (1<<RWWSRE) | (1<<SPMEN)
call Do_spm
rjmp Return

Do_spm:
; check for previous SPM complete
Wait_spm:
lds temp1, SPMCSR
sbrc temp1, SPEN
rjmp Wait_spm
; input: spmcsrval determines SPM action
; disable interrupts if enabled, store status
in temp2, SREG
cli
; check that no EEPROM write access is present

```

```

Wait_ee:
    sbic EECR, EEWE
    rjmp Wait_ee
    ; SPM timed sequence
    sts SPMCSR, spmcsrval
    spm
    ; restore SREG (to enable interrupts if originally enabled)
    out SREG, temp2
    ret
    
```

ATmega128 Boot Loader Parameters

In [Table 112](#) through [Table 114](#), the parameters used in the description of the self programming are given.

Table 112. Boot Size Configuration

| BOOTSZ1 | BOOTSZ0 | Boot Size | Pages | Application Flash Section | Boot Loader Flash Section | End Application section | Boot Reset Address (start Boot Loader Section) |
|---------|---------|------------|-------|---------------------------|---------------------------|-------------------------|--|
| 1 | 1 | 512 words | 4 | \$0000 - \$FDFF | \$FE00 - \$FFFF | \$FDFF | \$FE00 |
| 1 | 0 | 1024 words | 8 | \$0000 - \$FBFF | \$FC00 - \$FFFF | \$FBFF | \$FC00 |
| 0 | 1 | 2048 words | 16 | \$0000 - \$F7FF | \$F800 - \$FFFF | \$F7FF | \$F800 |
| 0 | 0 | 4096 words | 32 | \$0000 - \$EFFF | \$F000 - \$FFFF | \$EFFF | \$F000 |

Note: The different BOOTSZ fuse configurations are shown in [Figure 133](#)

Table 113. Read-While-Write Limit⁽¹⁾

| Section | Pages | Address |
|------------------------------------|-------|-----------------|
| Read-While-Write section (RWW) | 480 | \$0000 - \$EFFF |
| No Read-While-Write section (NRWW) | 32 | \$F000 - \$FFFF |

Note: 1. For details about these two section, see “[No Read-While-Write Section – NRWW](#)” on page 274 and “[Read-While-Write Section – RWW](#)” on page 274

Table 114. Explanation of Different Variables Used in [Figure 134](#) and the Mapping to the Z-Pointer⁽³⁾

| Variable | | Corresponding Z-value | Description ⁽²⁾ |
|----------|----------|------------------------|---|
| PCMSB | 15 | | Most significant bit in the program counter. (The program counter is 16 bits PC[15:0]) |
| PAGEMSB | 6 | | Most significant bit which is used to address the words within one page (128 words in a page requires 7 bits PC [6:0]). |
| ZPCMSB | | Z16 ⁽¹⁾ | Bit in Z-register that is mapped to PCMSB. Because Z0 is not used, the ZPCMSB equals PCMSB + 1. |
| ZPAGEMSB | | Z7 | Bit in Z-register that is mapped to PAGEMSB. Because Z0 is not used, the ZPAGEMSB equals PAGEMSB + 1. |
| PCPAGE | PC[15:7] | Z16 ⁽¹⁾ :Z8 | Program counter page address: Page select, for page erase and page write |
| PCWORD | PC[6:0] | Z7:Z1 | Program counter word address: Word select, for filling temporary buffer (must be zero during page write operation) |

- Notes:
1. The Z-register is only 16 bits wide. Bit 16 is located in the RAMPZ register in the I/O map.
 2. Z0: should be zero for all SPM commands, byte select for the (E)LPM instruction.
 3. See [“Addressing the Flash During Self-Programming” on page 278](#) for details about the use of Z-pointer during self-programming.

Memory Programming

Program and Data Memory Lock Bits

The Atmel® AVR®ATmega128 provides six Lock bits which can be left unprogrammed (“1”) or can be programmed (“0”) to obtain the additional features listed in [Table 116](#). The Lock bits can only be erased to “1” with the Chip Erase command.

Table 115. Lock Bit Byte

| Lock Bit Byte | Bit No. | Description | Default Value |
|---------------|---------|---------------|------------------|
| | 7 | – | 1 (unprogrammed) |
| | 6 | – | 1 (unprogrammed) |
| BLB12 | 5 | Boot lock bit | 1 (unprogrammed) |
| BLB11 | 4 | Boot lock bit | 1 (unprogrammed) |
| BLB02 | 3 | Boot lock bit | 1 (unprogrammed) |
| BLB01 | 2 | Boot lock bit | 1 (unprogrammed) |
| LB2 | 1 | Lock bit | 1 (unprogrammed) |
| LB1 | 0 | Lock bit | 1 (unprogrammed) |

Note: “1” means unprogrammed, “0” means programmed

Table 116. Lock Bit Protection Modes

| Memory Lock Bits | | | Protection Type |
|------------------|-------|-------|--|
| LB mode | LB2 | LB1 | |
| 1 | 1 | 1 | No memory lock features enabled. |
| 2 | 1 | 0 | Further programming of the Flash and EEPROM is disabled in Parallel and SPI/JTAG Serial Programming mode. The Fuse bits are locked in both Serial and Parallel Programming mode. ⁽¹⁾ |
| 3 | 0 | 0 | Further programming and verification of the Flash and EEPROM is disabled in Parallel and SPI/JTAG Serial Programming mode. The Fuse bits are locked in both Serial and Parallel Programming mode. ⁽¹⁾ |
| BLB0 mode | BLB02 | BLB01 | |
| 1 | 1 | 1 | No restrictions for SPM or (E)LPM accessing the Application section. |
| 2 | 1 | 0 | SPM is not allowed to write to the Application section. |
| 3 | 0 | 0 | SPM is not allowed to write to the Application section, and (E)LPM executing from the Boot Loader section is not allowed to read from the Application section. If interrupt vectors are placed in the Boot Loader section, interrupts are disabled while executing from the Application section. |
| 4 | 0 | 1 | (E)LPM executing from the Boot Loader section is not allowed to read from the Application section. If interrupt vectors are placed in the Boot Loader section, interrupts are disabled while executing from the Application section. |
| BLB1 mode | BLB12 | BLB11 | |

Table 116. Lock Bit Protection Modes (Continued)

| Memory Lock Bits | | | Protection Type |
|------------------|---|---|--|
| 1 | 1 | 1 | No restrictions for SPM or (E)LPM accessing the Boot Loader section. |
| 2 | 1 | 0 | SPM is not allowed to write to the Boot Loader section. |
| 3 | 0 | 0 | SPM is not allowed to write to the Boot Loader section, and (E)LPM executing from the Application section is not allowed to read from the Boot Loader section. If interrupt vectors are placed in the Application section, interrupts are disabled while executing from the Boot Loader section. |
| 4 | 0 | 1 | (E)LPM executing from the Application section is not allowed to read from the Boot Loader section. If interrupt vectors are placed in the Application section, interrupts are disabled while executing from the Boot Loader section. |

Notes: 1. Program the fuse bits before programming the Lock bits.
 2. "1" means unprogrammed, "0" means programmed

Fuse Bits

The Atmel® AVR®ATmega128 has three fuse bytes. [Table 117 - Table 119](#) describe briefly the functionality of all the fuses and how they are mapped into the fuse bytes. Note that the fuses are read as logical zero, "0", if they are programmed.

Table 117. Extended Fuse Byte

| Extended Fuse Byte | Bit No. | Description | Default Value |
|----------------------|---------|------------------------------|------------------|
| – | 7 | – | 1 |
| – | 6 | – | 1 |
| – | 5 | – | 1 |
| – | 4 | – | 1 |
| – | 3 | – | 1 |
| – | 2 | – | 1 |
| M103C ⁽¹⁾ | 1 | ATmega103 compatibility mode | 0 (programmed) |
| WDTON ⁽²⁾ | 0 | Watchdog Timer always on | 1 (unprogrammed) |

Notes: 1. See ["ATmega103 and ATmega128 Compatibility"](#) on page 4 for details.
 2. See ["Watchdog Timer Control Register – WDTCR"](#) on page 55 for details.

Table 118. Fuse High Byte

| Fuse High Byte | Bit No. | Description | Default Value |
|-----------------------|---------|--|--|
| OCDEN ⁽⁴⁾ | 7 | Enable OCD | 1 (unprogrammed, OCD disabled) |
| JTAGEN ⁽⁵⁾ | 6 | Enable JTAG | 0 (programmed, JTAG enabled) |
| SPIEN ⁽¹⁾ | 5 | Enable Serial Program and Data Downloading | 0 (programmed, SPI prog. enabled) |
| CKOPT ⁽²⁾ | 4 | Oscillator options | 1 (unprogrammed) |
| EESAVE | 3 | EEPROM memory is preserved through the Chip Erase | 1 (unprogrammed, EEPROM not preserved) |
| BOOTSZ1 | 2 | Select Boot Size (see Table 112 for details) | 0 (programmed) ⁽³⁾ |
| BOOTSZ0 | 1 | Select Boot Size (see Table 112 for details) | 0 (programmed) ⁽³⁾ |
| BOOTRST | 0 | Select Reset Vector | 1 (unprogrammed) |

- Notes:
1. The SPIEN fuse is not accessible in SPI Serial Programming mode.
 2. The CKOPT fuse functionality depends on the setting of the CKSEL bits. See [“Clock Sources” on page 36](#) for details.
 3. The default value of BOOTSZ1..0 results in maximum Boot Size. See [Table 112 on page 284](#)
 4. Never ship a product with the OCDEN Fuse programmed regardless of the setting of lock bits and the JTAGEN Fuse. A programmed OCDEN Fuse enables some parts of the clock system to be running in all sleep modes. This may increase the power consumption.
 5. If the JTAG interface is left unconnected, the JTAGEN fuse should if possible be disabled. This to avoid static current at the TDO pin in the JTAG interface.

Table 119. Fuse Low Byte

| Fuse Low Byte | Bit No. | Description | Default Value |
|---------------|---------|----------------------------------|---------------------------------|
| BODLEVEL | 7 | Brown out detector trigger level | 1 (unprogrammed) |
| BODEN | 6 | Brown out detector enable | 1 (unprogrammed, BOD disabled) |
| SUT1 | 5 | Select start-up time | 1 (unprogrammed) ⁽¹⁾ |
| SUT0 | 4 | Select start-up time | 0 (programmed) ⁽¹⁾ |
| CKSEL3 | 3 | Select Clock source | 0 (programmed) ⁽²⁾ |
| CKSEL2 | 2 | Select Clock source | 0 (programmed) ⁽²⁾ |
| CKSEL1 | 1 | Select Clock source | 0 (programmed) ⁽²⁾ |
| CKSEL0 | 0 | Select Clock source | 1 (unprogrammed) ⁽²⁾ |

- Notes:
1. The default value of SUT1..0 results in maximum start-up time. See [Table 14 on page 41](#) for details.
 2. The default setting of CKSEL3..0 results in Internal RC Oscillator @ 1MHz. See [Table 6 on page 36](#) for details.

The status of the Fuse bits is not affected by Chip Erase. Note that the Fuse bits are locked if Lock bit1 (LB1) is programmed. Program the Fuse bits before programming the Lock bits.

Latching of Fuses

The Fuse values are latched when the device enters Programming mode and changes of the fuse values will have no effect until the part leaves Programming mode. This does not apply to

the EESAVE fuse which will take effect once it is programmed. The fuses are also latched on power-up in normal mode.

Signature Bytes

All Atmel microcontrollers have a three-byte signature code which identifies the device. This code can be read in both serial and parallel mode, also when the device is locked. The three bytes reside in a separate address space.

For the Atmel® AVR® ATmega128 the signature bytes are:

1. \$000: \$1E (indicates manufactured by Atmel)
2. \$001: \$97 (indicates 128Kbyte Flash memory)
3. \$002: \$02 (indicates ATmega128 device when \$001 is \$97)

Calibration Byte

The ATmega128 stores four different calibration values for the internal RC Oscillator. These bytes reside in the signature row high byte of the addresses 0x000, 0x0001, 0x0002, and 0x0003 for 1MHz, 2MHz, 4MHz, and 8MHz respectively. During Reset, the 1MHz value is automatically loaded into the OSCCAL Register. If other frequencies are used, the calibration value has to be loaded manually, see “Oscillator Calibration Register – OSCCAL” on page 41 for details.

Parallel Programming Parameters, Pin Mapping, and Commands

This section describes how to parallel program and verify Flash Program memory, EEPROM Data memory, Memory Lock bits, and Fuse bits in the Atmel® AVR®ATmega128. Pulses are assumed to be at least 250ns unless otherwise noted.

Signal Names

In this section, some pins of the ATmega128 are referenced by signal names describing their functionality during parallel programming, see [Figure 135](#) and [Table 120](#). Pins not described in the following table are referenced by pin names.

The XA1/XA0 pins determine the action executed when the XTAL1 pin is given a positive pulse. The bit coding is shown in [Table 122](#).

When pulsing \overline{WR} or \overline{OE} , the command loaded determines the action executed. The different Commands are shown in [Table 123](#).

Figure 135. Parallel Programming



Table 120. Pin Name Mapping

| Signal Name in Programming Mode | Pin Name | I/O | Function |
|---------------------------------|----------|-----|---|
| RDY/ \overline{BSY} | PD1 | O | 0: Device is busy programming, 1: Device is ready for new command |
| \overline{OE} | PD2 | I | Output Enable (Active low) |
| \overline{WR} | PD3 | I | Write Pulse (Active low) |
| BS1 | PD4 | I | Byte Select 1 ("0" selects low byte, "1" selects high byte) |
| XA0 | PD5 | I | XTAL Action Bit 0 |
| XA1 | PD6 | I | XTAL Action Bit 1 |

Table 120. Pin Name Mapping (Continued)

| Signal Name in Programming Mode | Pin Name | I/O | Function |
|---------------------------------|----------|-----|--|
| PAGEL | PD7 | I | Program Memory and EEPROM data Page Load |
| BS2 | PA0 | I | Byte Select 2 (“0” selects low byte, “1” selects 2’nd high byte) |
| DATA | PB7-0 | I/O | Bi-directional Data bus (Output when \overline{OE} is low) |

Table 121. Pin Values Used to Enter Programming Mode

| Pin | Symbol | Value |
|-------|----------------|-------|
| PAGEL | Prog_enable[3] | 0 |
| XA1 | Prog_enable[2] | 0 |
| XA0 | Prog_enable[1] | 0 |
| BS1 | Prog_enable[0] | 0 |

Table 122. XA1 and XA0 Coding

| XA1 | XA0 | Action when XTAL1 is Pulsed |
|-----|-----|---|
| 0 | 0 | Load Flash or EEPROM Address (High or low address byte determined by BS1) |
| 0 | 1 | Load Data (High or Low data byte for Flash determined by BS1) |
| 1 | 0 | Load Command |
| 1 | 1 | No Action, Idle |

Table 123. Command Byte Bit Coding

| Command Byte | Command Executed |
|--------------|---|
| 1000 0000 | Chip Erase |
| 0100 0000 | Write Fuse bits |
| 0010 0000 | Write Lock bits |
| 0001 0000 | Write Flash |
| 0001 0001 | Write EEPROM |
| 0000 1000 | Read Signature Bytes and Calibration byte |
| 0000 0100 | Read Fuse and Lock bits |
| 0000 0010 | Read Flash |
| 0000 0011 | Read EEPROM |

Table 124. No. of Words in a Page and no. of Pages in the Flash

| Flash Size | Page Size | PCWORD | No. of Pages | PCPAGE | PCMSB |
|------------------------|-----------|---------|--------------|----------|-------|
| 64K words (128 Kbytes) | 128 words | PC[6:0] | 512 | PC[15:7] | 15 |

Table 125. No. of Words in a Page and no. of Pages in the EEPROM

| EEPROM Size | Page Size | PCWORD | No. of Pages | PCPAGE | EEAMSB |
|-------------|-----------|----------|--------------|-----------|--------|
| 4 Kbytes | 8 bytes | EEA[2:0] | 512 | EEA[11:3] | 8 |

Parallel Programming

Enter Programming Mode

The following algorithm puts the device in parallel programming mode:

1. Apply 4.5V - 5.5V between V_{CC} and GND, and wait at least 100 μ s.
2. Set \overline{RESET} to "0" and toggle XTAL1 at least SIX times.
3. Set the Prog_enable pins listed in [Table 121 on page 291](#) to "0000" and wait at least 100ns.
4. Apply 11.5 - 12.5V to \overline{RESET} . Any activity on Prog_enable pins within 100ns after +12V has been applied to \overline{RESET} , will cause the device to fail entering programming mode.

Note, if External Crystal or External RC configuration is selected, it may not be possible to apply qualified XTAL1 pulses. In such cases, the following algorithm should be followed:

1. Set Prog_enable pins listed in [Table on page 291](#) to "0000".
2. Apply 4.5 - 5.5V between V_{CC} and GND simultaneously as 11.5 - 12.5V is applied to \overline{RESET} .
3. Wait 100 μ s.
4. Re-program the fuses to ensure that External Clock is selected as clock source (CKSEL3:0 = 0b0000) If Lock bits are programmed, a Chip Erase command must be executed before changing the fuses.
5. Exit Programming mode by power the device down or by bringing \overline{RESET} pin to 0b0.
6. Entering Programming mode with the original algorithm, as described above.

Considerations for Efficient Programming

The loaded command and address are retained in the device during programming. For efficient programming, the following should be considered.

- The command needs only be loaded once when writing or reading multiple memory locations.
- Skip writing the data value \$FF, that is the contents of the entire EEPROM (unless the EESAVE fuse is programmed) and Flash after a Chip Erase.
- Address high byte needs only be loaded before programming or reading a new 256 word window in Flash or 256-byte EEPROM. This consideration also applies to Signature bytes reading.

Chip Erase

The Chip Erase will erase the Flash and EEPROM⁽¹⁾ memories plus Lock bits. The Lock bits are not reset until the program memory has been completely erased. The Fuse bits are not changed. A Chip Erase must be performed before the Flash and/or the EEPROM are reprogrammed.

Note: 1. The EEPROM memory is preserved during chip erase if the EESAVE fuse is programmed.

Load Command "Chip Erase"

1. Set XA1, XA0 to "10". This enables command loading.
2. Set BS1 to "0".
3. Set DATA to "1000 0000". This is the command for Chip Erase.
4. Give XTAL1 a positive pulse. This loads the command.

5. Give \overline{WR} a negative pulse. This starts the Chip Erase. RDY/\overline{BSY} goes low.
6. Wait until RDY/\overline{BSY} goes high before loading a new command.

Programming the Flash

The Flash is organized in pages, see [Table 123 on page 291](#). When programming the Flash, the program data is latched into a page buffer. This allows one page of program data to be programmed simultaneously. The following procedure describes how to program the entire Flash memory:

A. Load Command "Write Flash"

1. Set XA1, XA0 to "10". This enables command loading.
2. Set BS1 to "0".
3. Set DATA to "0001 0000". This is the command for Write Flash.
4. Give XTAL1 a positive pulse. This loads the command.

B. Load Address Low byte

1. Set XA1, XA0 to "00". This enables address loading.
2. Set BS1 to "0". This selects low address.
3. Set DATA = Address low byte (\$00 - \$FF).
4. Give XTAL1 a positive pulse. This loads the address low byte.

C. Load Data Low Byte

1. Set XA1, XA0 to "01". This enables data loading.
2. Set DATA = Data low byte (\$00 - \$FF).
3. Give XTAL1 a positive pulse. This loads the data byte.

D. Load Data High Byte

1. Set BS1 to "1". This selects high data byte.
2. Set XA1, XA0 to "01". This enables data loading.
3. Set DATA = Data high byte (\$00 - \$FF).
4. Give XTAL1 a positive pulse. This loads the data byte.

E. Latch Data

1. Set BS1 to "1". This selects high data byte.
2. Give PAGESL a positive pulse. This latches the data bytes. (See [Figure 137](#) for signal waveforms)

F. Repeat B through E until the entire buffer is filled or until all data within the page is loaded.

While the lower bits in the address are mapped to words within the page, the higher bits address the pages within the FLASH. This is illustrated in [Figure 136 on page 294](#). Note that if less than 8 bits are required to address words in the page (pagesize < 256), the most significant bit(s) in the address low byte are used to address the page when performing a page write.

G. Load Address High byte

1. Set XA1, XA0 to "00". This enables address loading.
2. Set BS1 to "1". This selects high address.
3. Set DATA = Address high byte (\$00 - \$FF).
4. Give XTAL1 a positive pulse. This loads the address high byte.

H. Program Page

1. Set BS1 = "0"
 2. Give \overline{WR} a negative pulse. This starts programming of the entire page of data. RDY/\overline{BSY} goes low.
 3. Wait until RDY/\overline{BSY} goes high. (See [Figure 137](#) for signal waveforms)
- I. Repeat B through H until the entire Flash is programmed or until all data has been programmed.
- J. End Page Programming
1. Set XA1, XA0 to "10". This enables command loading.
 2. Set DATA to "0000 0000". This is the command for No Operation.
 3. Give XTAL1 a positive pulse. This loads the command, and the internal write signals are reset.

Figure 136. Addressing the Flash which is Organized in Pages



Note: 1. PCPAGE and PCWORD are listed in [Table 124](#) on page 291.

Figure 137. Programming the Flash Waveforms



Note: "XX" is don't care. The letters refer to the programming description above.

Programming the EEPROM

The EEPROM is organized in pages, see [Table 124 on page 291](#). When programming the EEPROM, the program data is latched into a page buffer. This allows one page of data to be programmed simultaneously. The programming algorithm for the EEPROM data memory is as follows (refer to ["Programming the Flash" on page 293](#) for details on Command, Address and Data loading):

1. A: Load Command "0001 0001".
 2. G: Load Address High Byte (\$00 - \$FF).
 3. B: Load Address Low Byte (\$00 - \$FF).
 4. C: Load Data (\$00 - \$FF).
 5. E: Latch data (give PAGEL a positive pulse).
- K: Repeat 3 through 5 until the entire buffer is filled.
- L: Program EEPROM page:
1. Set BS1 to "0".
 2. Give \overline{WR} a negative pulse. This starts programming of the EEPROM page. RDY/ \overline{BSY} goes low.
 3. Wait until RDY/ \overline{BSY} goes high before programming the next page. (See [Figure 138](#) for signal waveforms.)

Figure 138. Programming the EEPROM Waveforms



Reading the Flash

The algorithm for reading the Flash memory is as follows (refer to [“Programming the Flash” on page 293](#) for details on Command and Address loading):

1. A: Load Command “0000 0010”.
2. G: Load Address High Byte (\$00 - \$FF).
3. B: Load Address Low Byte (\$00 - \$FF).
4. Set \overline{OE} to “0”, and BS1 to “0”. The Flash word low byte can now be read at DATA.
5. Set BS1 to “1”. The Flash word high byte can now be read at DATA.
6. Set \overline{OE} to “1”.

Reading the EEPROM

The algorithm for reading the EEPROM memory is as follows (refer to [“Programming the Flash” on page 293](#) for details on Command and Address loading):

1. A: Load Command “0000 0011”.
2. G: Load Address High Byte (\$00 - \$FF).
3. B: Load Address Low Byte (\$00 - \$FF).
4. Set \overline{OE} to “0”, and BS1 to “0”. The EEPROM Data byte can now be read at DATA.
5. Set \overline{OE} to “1”.

Programming the Fuse Low Bits

The algorithm for programming the Fuse Low bits is as follows (refer to [“Programming the Flash” on page 293](#) for details on Command and Data loading):

1. A: Load Command “0100 0000”.
2. C: Load Data Low Byte. Bit n = “0” programs and bit n = “1” erases the Fuse bit.
3. Set BS1 to “0” and BS2 to “0”.
4. Give \overline{WR} a negative pulse and wait for $\overline{RDY/BSY}$ to go high.

Programming the Fuse High Bits

The algorithm for programming the Fuse High bits is as follows (refer to [“Programming the Flash” on page 293](#) for details on Command and Data loading):

1. A: Load Command “0100 0000”.
2. C: Load Data Low Byte. Bit n = “0” programs and bit n = “1” erases the Fuse bit.
3. Set BS1 to “1” and BS2 to “0”. This selects high data byte.
4. Give \overline{WR} a negative pulse and wait for RDY/ \overline{BSY} to go high.
5. Set BS1 to “0”. This selects low data byte.

Programming the Extended Fuse Bits

The algorithm for programming the Extended Fuse bits is as follows (refer to [“Programming the Flash” on page 293](#) for details on Command and Data loading):

1. A: Load Command “0100 0000”.
2. C: Load Data Low Byte. Bit n = “0” programs and bit n = “1” erases the Fuse bit.
3. Set BS2 to “1” and BS1 to “0”. This selects extended data byte.
4. Give \overline{WR} a negative pulse and wait for RDY/ \overline{BSY} to go high.
5. Set BS2 to “0”. This selects low data byte.

Figure 139. Programming the Fuses



Programming the Lock Bits

The algorithm for programming the Lock bits is as follows (refer to [“Programming the Flash” on page 293](#) for details on Command and Data loading):

1. A: Load Command “0010 0000”.
2. C: Load Data Low Byte. Bit n = “0” programs the Lock bit.
3. Give \overline{WR} a negative pulse and wait for RDY/ \overline{BSY} to go high.

The Lock bits can only be cleared by executing Chip Erase.

Reading the Fuse and Lock Bits

The algorithm for reading the Fuse and Lock bits is as follows (refer to [“Programming the Flash” on page 293](#) for details on Command loading):

1. A: Load Command “0000 0100”.
2. Set \overline{OE} to “0”, BS2 to “0”, and BS1 to “0”. The status of the Fuse Low bits can now be read at DATA (“0” means programmed).
3. Set \overline{OE} to “0”, BS2 to “1”, and BS1 to “1”. The status of the Fuse High bits can now be read at DATA (“0” means programmed).

4. Set \overline{OE} to "0", BS2 to "1", and BS1 to "0". The status of the Extended Fuse bits can now be read at DATA ("0" means programmed).
5. Set \overline{OE} to "0", BS2 to "0", and BS1 to "1". The status of the Lock bits can now be read at DATA ("0" means programmed).
6. Set \overline{OE} to "1".

Figure 140. Mapping Between BS1, BS2 and the Fuse- and Lock Bits During Read

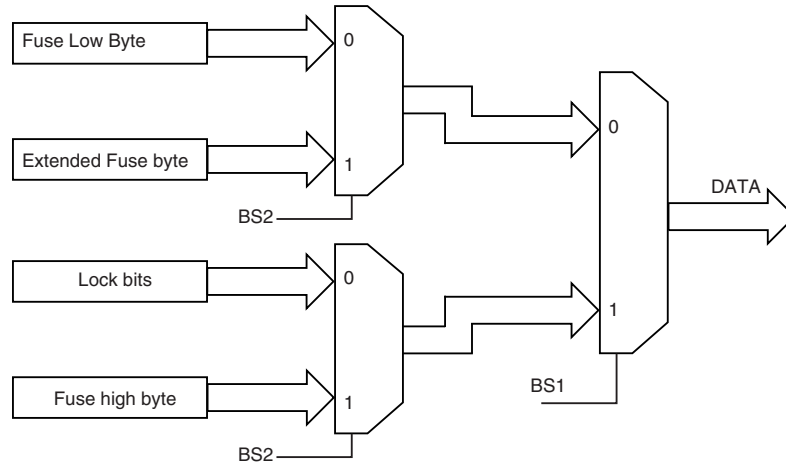

Reading the Signature Bytes

The algorithm for reading the Signature bytes is as follows (refer to Programming the Flash for details on Command and Address loading):

1. A: Load Command "0000 1000".
2. B: Load Address Low Byte (\$00 - \$02).
3. Set \overline{OE} to "0", and BS1 to "0". The selected Signature byte can now be read at DATA.
4. Set \overline{OE} to "1".

Reading the Calibration Byte

The algorithm for reading the Calibration byte is as follows (refer to Programming the Flash for details on Command and Address loading):

1. A: Load Command "0000 1000".
2. B: Load Address Low Byte.
3. Set \overline{OE} to "0", and BS1 to "1". The Calibration byte can now be read at DATA.
4. Set \overline{OE} to "1".

Parallel Programming Characteristics

Figure 141. Parallel Programming Timing, Including some General Timing Requirements

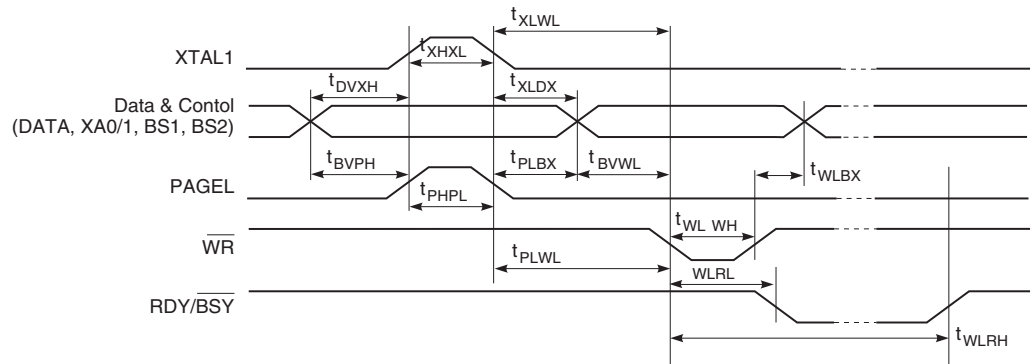

Figure 142. Parallel Programming Timing, Loading Sequence with Timing Requirements



Note: The timing requirements shown in Figure 141 (i.e. t_{DVXH} , t_{XHXL} , and t_{XLDX}) also apply to loading operation.

Figure 143. Parallel Programming Timing, Reading Sequence (Within the Same Page) with Timing Requirements



Note: The timing requirements shown in Figure 141 (i.e. t_{DVXH} , t_{XHXL} , and t_{XLDX}) also apply to reading operation.

Table 126. Parallel Programming Characteristics, $V_{CC} = 5 V \pm 10\%$

| Symbol | Parameter | Min | Typ | Max | Units |
|------------|--|------|-----|------|---------|
| V_{PP} | Programming Enable Voltage | 11.5 | | 12.5 | V |
| I_{PP} | Programming Enable Current | | | 250 | μA |
| t_{DVXH} | Data and Control Valid before XTAL1 High | 67 | | | ns |
| t_{XLXH} | XTAL1 Low to XTAL1 High | 200 | | | ns |
| t_{XHXL} | XTAL1 Pulse Width High | 150 | | | ns |
| t_{XLDX} | Data and Control Hold after XTAL1 Low | 67 | | | ns |
| t_{XLWL} | XTAL1 Low to \overline{WR} Low | 0 | | | ns |

Table 126. Parallel Programming Characteristics, $V_{CC} = 5 V \pm 10\%$ (Continued)

| Symbol | Parameter | Min | Typ | Max | Units |
|----------------|---|-----|-----|-----|---------|
| t_{XLPH} | XTAL1 Low to PAgEL high | 0 | | | ns |
| t_{PLXH} | PAGEL low to XTAL1 high | 150 | | | ns |
| t_{BVPH} | BS1 Valid before PAgEL High | 67 | | | ns |
| t_{PHPL} | PAGEL Pulse Width High | 150 | | | ns |
| t_{PLBX} | BS1 Hold after PAgEL Low | 67 | | | ns |
| t_{WLBX} | BS2/1 Hold after \overline{WR} Low | 67 | | | ns |
| t_{PLWL} | PAGEL Low to \overline{WR} Low | 67 | | | ns |
| t_{BVWL} | BS1 Valid to \overline{WR} Low | 67 | | | ns |
| t_{WLWH} | \overline{WR} Pulse Width Low | 150 | | | ns |
| t_{WLRL} | \overline{WR} Low to RDY/ \overline{BSY} Low | 0 | | 1 | μs |
| t_{WLRH} | \overline{WR} Low to RDY/ \overline{BSY} High ⁽¹⁾ | 3.7 | | 5 | ms |
| t_{WLRH_CE} | \overline{WR} Low to RDY/ \overline{BSY} High for Chip Erase ⁽²⁾ | 7.5 | | 10 | ms |
| t_{XL0L} | XTAL1 Low to \overline{OE} Low | 0 | | | ns |
| t_{BVDV} | BS1 Valid to DATA valid | 0 | | 250 | ns |
| t_{OLDV} | \overline{OE} Low to DATA Valid | | | 250 | ns |
| t_{OHDZ} | \overline{OE} High to DATA Tri-stated | | | 250 | ns |

- Notes: 1. t_{WLRH} is valid for the Write Flash, Write EEPROM, Write Fuse bits and Write Lock bits commands.
 2. t_{WLRH_CE} is valid for the Chip Erase command.

Serial Downloading

Both the Flash and EEPROM memory arrays can be programmed using the serial SPI bus while RESET is pulled to GND. The serial interface consists of pins SCK, MOSI (input) and MISO (output). After RESET is set low, the Programming Enable instruction needs to be executed first before program/erase operations can be executed. NOTE, in [Table 127 on page 300](#), the pin mapping for SPI programming is listed. Not all parts use the SPI pins dedicated for the internal SPI interface. Note that throughout the description about Serial downloading, MOSI and MISO are used to describe the serial data in and serial data out respectively. For Atmel® AVR® ATmega128 these pins are mapped to PDI and PDO.

SPI Serial Programming Pin Mapping

Even though the SPI Programming interface re-uses the SPI I/O module, there is one important difference: The MOSI/MISO pins that are mapped to PB2 and PB3 in the SPI I/O module are not used in the Programming interface. Instead, PE0 and PE1 are used for data in SPI Programming mode as shown in [Table 127](#).

Table 127. Pin Mapping SPI Serial Programming

| Symbol | Pins | I/O | Description |
|------------|------|-----|-----------------|
| MOSI (PDI) | PE0 | I | Serial data in |
| MISO (PDO) | PE1 | O | Serial data out |
| SCK | PB1 | I | Serial clock |

Figure 144. SPI Serial Programming and Verify⁽¹⁾



- Notes:
1. If the device is clocked by the Internal Oscillator, it is no need to connect a clock source to the XTAL1 pin.
 2. $V_{CC} - 0.3V < AVCC < V_{CC} + 0.3V$, however, AVCC should always be within 2.7 - 5.5V.

When programming the EEPROM, an auto-erase cycle is built into the self-timed programming operation (in the serial mode ONLY) and there is no need to first execute the Chip Erase instruction. The Chip Erase operation turns the content of every memory location in both the Program and EEPROM arrays into \$FF.

Depending on CKSEL Fuses, a valid clock must be present. The minimum low and high periods for the serial clock (SCK) input are defined as follows:

Low:> 2 CPU clock cycles for $f_{ck} < 12\text{MHz}$, 3 CPU clock cycles for $f_{ck} \geq 12\text{MHz}$

High:> 2 CPU clock cycles for $f_{ck} < 12\text{MHz}$, 3 CPU clock cycles for $f_{ck} \geq 12\text{MHz}$

SPI Serial Programming Algorithm

When writing serial data to the ATmega128, data is clocked on the rising edge of SCK.

When reading data from the ATmega128, data is clocked on the falling edge of SCK. See [Figure 145](#) for timing details.

To program and verify the ATmega128 in the SPI Serial Programming mode, the following sequence is recommended (See four byte instruction formats in [Table 145](#)):

1. Power-up sequence:

Apply power between V_{CC} and GND while $\overline{\text{RESET}}$ and SCK are set to "0". In some systems, the programmer can not guarantee that SCK is held low during power-up. In this case, $\overline{\text{RESET}}$ must be given a positive pulse of at least two CPU clock cycles duration after SCK has been set to "0".

As an alternative to using the RESET signal, $\overline{\text{PEN}}$ can be held low during Power-on Reset while SCK is set to "0". In this case, only the $\overline{\text{PEN}}$ value at Power-on Reset is important. If the programmer cannot guarantee that SCK is held low during power-up, the $\overline{\text{PEN}}$ method cannot be used. The device must be powered down in order to commence normal operation when using this method.
2. Wait for at least 20 ms and enable SPI Serial Programming by sending the Programming Enable serial instruction to pin MOSI.

3. The SPI Serial Programming instructions will not work if the communication is out of synchronization. When in sync, the second byte (\$53), will echo back when issuing the third byte of the Programming Enable instruction. Whether the echo is correct or not, all FOUR bytes of the instruction must be transmitted. If the \$53 did not echo back, give $\overline{\text{RESET}}$ a positive pulse and issue a new Programming Enable command.
4. The Flash is programmed one page at a time. The page size is found in [Table 124 on page 291](#). The memory page is loaded one byte at a time by supplying the 7 LSB of the address and data together with the Load Program Memory Page instruction. To ensure correct loading of the page, the data low byte must be loaded before data high byte is applied for given address. The Program Memory Page is stored by loading the Write Program Memory Page instruction with the 9MSB of the address. If polling is not used, the user must wait at least $t_{\text{WD_FLASH}}$ before issuing the next page. (See [Table 128](#)).
 Note: If other commands than polling (read) are applied before any write operation (Flash, EEPROM, Lock bits, Fuses) is completed, may result in incorrect programming.
5. The EEPROM array is programmed one byte at a time by supplying the address and data together with the appropriate Write instruction. An EEPROM memory location is first automatically erased before new data is written. If polling is not used, the user must wait at least $t_{\text{WD_EEPROM}}$ before issuing the next byte. (See [Table 128](#)). In a chip erased device, no \$FFs in the data file(s) need to be programmed.
6. Any memory location can be verified by using the Read instruction which returns the content at the selected address at serial output MISO.
7. At the end of the programming session, $\overline{\text{RESET}}$ can be set high to commence normal operation.
8. Power-off sequence (if needed):
 Set $\overline{\text{RESET}}$ to "1".
 Turn V_{CC} power off.

Data Polling Flash

When a page is being programmed into the Flash, reading an address location within the page being programmed will give the value \$FF. At the time the device is ready for a new page, the programmed value will read correctly. This is used to determine when the next page can be written. Note that the entire page is written simultaneously and any address within the page can be used for polling. Data polling of the Flash will not work for the value \$FF, so when programming this value, the user will have to wait for at least $t_{\text{WD_FLASH}}$ before programming the next page. As a chip-erased device contains \$FF in all locations, programming of addresses that are meant to contain \$FF, can be skipped. See [Table 128](#) for $t_{\text{WD_FLASH}}$ value

Data Polling EEPROM

When a new byte has been written and is being programmed into EEPROM, reading the address location being programmed will give the value \$FF. At the time the device is ready for a new byte, the programmed value will read correctly. This is used to determine when the next byte can be written. This will not work for the value \$FF, but the user should have the following in mind: As a chip-erased device contains \$FF in all locations, programming of addresses that are meant to contain \$FF, can be skipped. This does not apply if the EEPROM is re-programmed without chip-erasing the device. In this case, data polling cannot be used for the value \$FF, and the user will have to wait at least $t_{\text{WD_EEPROM}}$ before programming the next byte. See [Table 128](#) for $t_{\text{WD_EEPROM}}$ value.

Table 128. Minimum Wait Delay before Writing the Next Flash or EEPROM Location, $V_{CC} = 5V \pm 10\%$

| Symbol | Minimum Wait Delay |
|------------------|--------------------|
| t_{WD_FUZE} | 4.5ms |
| t_{WD_FLASH} | 5ms |
| t_{WD_EEPROM} | 10ms |
| t_{WD_ERASE} | 10ms |

Figure 145. .SPI Serial Programming Waveforms

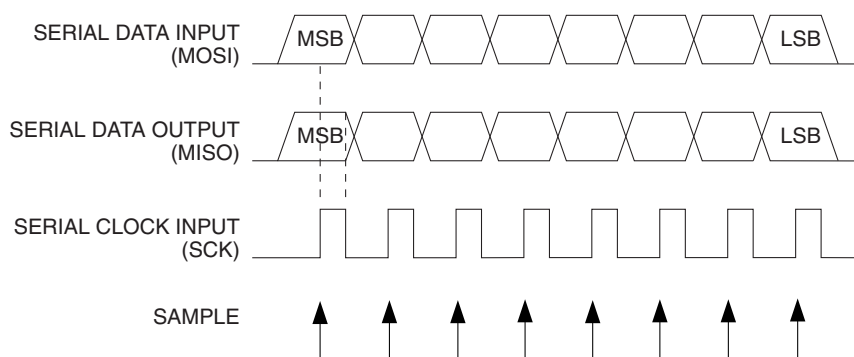

Table 129. SPI Serial Programming Instruction Set

| Instruction | Instruction Format | | | | Operation |
|---------------------------|--------------------|-----------|-----------|------------|---|
| | Byte 1 | Byte 2 | Byte 3 | Byte 4 | |
| Programming Enable | 1010 1100 | 0101 0011 | xxxx xxxx | xxxx xxxx | Enable SPI Serial Programming after $\overline{\text{RESET}}$ goes low. |
| Chip Erase | 1010 1100 | 100x xxxx | xxxx xxxx | xxxx xxxx | Chip Erase EEPROM and Flash. |
| Read Program Memory | 0010 H000 | aaaa aaaa | bbbb bbbb | oooo oooo | Read H (high or low) data o from Program memory at word address a:b . |
| Load Program Memory Page | 0100 H000 | xxxx xxxx | xbbb bbbb | iiii iiiii | Write H (high or low) data i to Program Memory page at word address b . Data low byte must be loaded before data high byte is applied within the same address. |
| Write Program Memory Page | 0100 1100 | aaaa aaaa | bxxx xxxx | xxxx xxxx | Write Program Memory Page at address a:b . |
| Read EEPROM Memory | 1010 0000 | xxxx aaaa | bbbb bbbb | oooo oooo | Read data o from EEPROM memory at address a:b . |
| Write EEPROM Memory | 1100 0000 | xxxx aaaa | bbbb bbbb | iiii iiiii | Write data i to EEPROM memory at address a:b . |
| Read Lock bits | 0101 1000 | 0000 0000 | xxxx xxxx | xxoo oooo | Read Lock bits. "0" = programmed, "1" = unprogrammed. See Table 115 on page 286 for details. |
| Write Lock bits | 1010 1100 | 111x xxxx | xxxx xxxx | 11ii iiiii | Write Lock bits. Set bits = "0" to program Lock bits. See Table 115 on page 286 for details. |
| Read Signature Byte | 0011 0000 | xxxx xxxx | xxxx xxbb | oooo oooo | Read Signature Byte o at address b . |
| Write Fuse bits | 1010 1100 | 1010 0000 | xxxx xxxx | iiii iiiii | Set bits = "0" to program, "1" to unprogram. See Table 119 on page 288 for details. |
| Write Fuse High Bits | 1010 1100 | 1010 1000 | xxxx xxxx | iiii iiiii | Set bits = "0" to program, "1" to unprogram. See Table 118 on page 288 for details. |
| Write Extended Fuse bits | 1010 1100 | 1010 0100 | xxxx xxxx | xxxx xxii | Set bits = "0" to program, "1" to unprogram. See Table 119 on page 288 for details. |
| Read Fuse bits | 0101 0000 | 0000 0000 | xxxx xxxx | oooo oooo | Read Fuse bits. "0" = programmed, "1" = unprogrammed. See Table 119 on page 288 for details. |
| Read Extended Fuse bits | 0101 0000 | 0000 1000 | xxxx xxxx | oooo oooo | Read Extended Fuse bits. "0" = programmed, "1" = unprogrammed. See Table 119 on page 288 for details. |
| Read Fuse High Bits | 0101 1000 | 0000 1000 | xxxx xxxx | oooo oooo | Read Fuse high bits. "0" = programmed, "1" = unprogrammed. See Table 118 on page 288 for details. |
| Read Calibration Byte | 0011 1000 | xxxx xxxx | 0000 00bb | oooo oooo | Read Calibration Byte o at address b . |

Note: **a** = address high bits
b = address low bits
H = 0 - Low byte, 1 - High Byte
o = data out
i = data in
x = don't care

SPI Serial Programming Characteristics

For characteristics of the SPI module, see [“SPI Timing Characteristics” on page 323](#).

Programming Via the JTAG Interface

Programming through the JTAG interface requires control of the four JTAG specific pins: TCK, TMS, TDI, and TDO. Control of the Reset and clock pins is not required.

To be able to use the JTAG interface, the JTAGEN fuse must be programmed. The device is default shipped with the Fuse programmed. In addition, the JTD bit in MCUCSR must be cleared. Alternatively, if the JTD bit is set, the external reset can be forced low. Then, the JTD bit will be cleared after two chip clocks, and the JTAG pins are available for programming. This provides a means of using the JTAG pins as normal port pins in running mode while still allowing In-System Programming via the JTAG interface. Note that this technique can not be used when using the JTAG pins for Boundary-scan or On-chip Debug. In these cases the JTAG pins must be dedicated for this purpose.

As a definition in this data sheet, the LSB is shifted in and out first of all Shift Registers.

Programming Specific JTAG Instructions

The instruction register is 4-bit wide, supporting up to 16 instructions. The JTAG instructions useful for Programming are listed below.

The OPCODE for each instruction is shown behind the instruction name in hex format. The text describes which data register is selected as path between TDI and TDO for each instruction.

The Run-Test/Idle state of the TAP controller is used to generate internal clocks. It can also be used as an idle state between JTAG sequences. The state machine sequence for changing the instruction word is shown in [Figure 146](#).

Figure 146. State Machine Sequence for Changing the Instruction Word



AVR_RESET (\$C)

The AVR specific public JTAG instruction for setting the AVR device in the Reset mode or taking the device out from the Reset mode. The TAP controller is not reset by this instruction. The one bit Reset Register is selected as Data Register. Note that the reset will be active as long as there is a logic 'one' in the Reset Chain. The output from this chain is not latched.

The active states are:

- Shift-DR: The Reset Register is shifted by the TCK input.

PROG_ENABLE (\$4)

The AVR specific public JTAG instruction for enabling programming via the JTAG port. The 16-bit Programming Enable Register is selected as data register. The active states are the following:

- Shift-DR: the programming enable signature is shifted into the data register.
- Update-DR: the programming enable signature is compared to the correct value, and Programming mode is entered if the signature is valid.

PROG_COMMANDS (\$5)

The AVR specific public JTAG instruction for entering programming commands via the JTAG port. The 15-bit Programming Command Register is selected as data register. The active states are the following:

- Capture-DR: the result of the previous command is loaded into the data register.
- Shift-DR: the data register is shifted by the TCK input, shifting out the result of the previous command and shifting in the new command.
- Update-DR: the programming command is applied to the Flash inputs.
- Run-Test/Idle: one clock cycle is generated, executing the applied command.

PROG_PAGELOAD (\$6)

The AVR specific public JTAG instruction to directly load the Flash data page via the JTAG port. The 2048-bit Virtual Flash Page Load Register is selected as data register. This is a virtual scan chain with length equal to the number of bits in one Flash page. Internally the Shift Register is 8-bit. Unlike most JTAG instructions, the Update-DR state is not used to transfer data from the Shift Register. The data are automatically transferred to the Flash page buffer byte by byte in the Shift-DR state by an internal state machine. This is the only active state:

- Shift-DR: Flash page data are shifted in from TDI by the TCK input, and automatically loaded into the Flash page one byte at a time.

Note: The JTAG instruction PROG_PAGELOAD can only be used if the AVR device is the first device in JTAG scan chain. If the AVR cannot be the first device in the scan chain, the byte-wise programming algorithm must be used.

PROG_PAGEREAD (\$7)

The AVR specific public JTAG instruction to read one full Flash data page via the JTAG port. The 2056-bit Virtual Flash Page Read Register is selected as data register. This is a virtual scan chain with length equal to the number of bits in one Flash page plus 8. Internally the Shift Register is 8-bit. Unlike most JTAG instructions, the Capture-DR state is not used to transfer data to the Shift Register. The data are automatically transferred from the Flash page buffer byte by byte in the Shift-DR state by an internal state machine. This is the only active state:

- Shift-DR: Flash data are automatically read one byte at a time and shifted out on TDO by the TCK input. The TDI input is ignored.

Note: The JTAG instruction PROG_PAGEREAD can only be used if the AVR device is the first device in JTAG scan chain. If the AVR cannot be the first device in the scan chain, the byte-wise programming algorithm must be used.

Data Registers

The data registers are selected by the JTAG instruction registers described in section [“Programming Specific JTAG Instructions” on page 305](#). The data registers relevant for programming operations are:

- Reset Register
- Programming Enable Register
- Programming Command Register
- Virtual Flash Page Load Register
- Virtual Flash Page Read Register

Reset Register

The Reset Register is a Test Data Register used to reset the part during programming. It is required to reset the part before entering programming mode.

A high value in the Reset Register corresponds to pulling the external Reset low. The part is reset as long as there is a high value present in the Reset Register. Depending on the Fuse settings for the clock options, the part will remain reset for a Reset Time-Out Period (refer to “[Clock Sources](#)” on page 36) after releasing the Reset Register. The output from this Data Register is not latched, so the reset will take place immediately, as shown in [Figure 123](#) on page 254.

Programming Enable Register

The Programming Enable Register is a 16-bit register. The contents of this register is compared to the programming enable signature, binary code 1010_0011_0111_0000. When the contents of the register is equal to the programming enable signature, programming via the JTAG port is enabled. The Register is reset to 0 on Power-on Reset, and should always be reset when leaving Programming mode.

Figure 147. Programming Enable Register



**Programming
Command Register**

The Programming Command Register is a 15-bit register. This register is used to serially shift in programming commands, and to serially shift out the result of the previous command, if any. The JTAG Programming Instruction Set is shown in [Table 130](#). The state sequence when shifting in the programming commands is illustrated in [Figure 149](#).

Figure 148. Programming Command Register

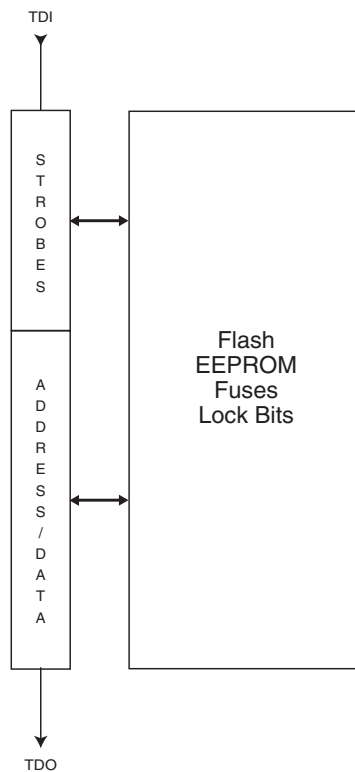

Table 130. JTAG Programming Instruction

Set **a** = address high bits, **b** = address low bits, **H** = 0 - Low Byte, 1 - High Byte, **o** = data out, **i** = data in, **x** = don't care

| Instruction | TDI sequence | TDO sequence | Notes |
|----------------------------------|--|--|-----------------------|
| 1a. Chip erase | 0100011_10000000 0110001_10000000 0110011_10000000 0110011_10000000 | xxxxxxx_xxxxxxxx xxxxxxx_xxxxxxxx xxxxxxx_xxxxxxxx xxxxxxx_xxxxxxxx | |
| 1b. Poll for chip erase complete | 0110011_10000000 | xxxxx o x_xxxxxxxx | (2) |
| 2a. Enter Flash Write | 0100011_00010000 | xxxxxxx_xxxxxxxx | |
| 2b. Load Address High Byte | 0000111_aaaaaaa | xxxxxxx_xxxxxxxx | (9) |
| 2c. Load Address Low Byte | 0000011_bbbbbbbb | xxxxxxx_xxxxxxxx | |
| 2d. Load Data Low Byte | 0010011_iiiiiii | xxxxxxx_xxxxxxxx | |
| 2e. Load Data High Byte | 0010111_iiiiiii | xxxxxxx_xxxxxxxx | |
| 2f. Latch Data | 0110111_00000000 1110111_00000000 0110111_00000000 | xxxxxxx_xxxxxxxx xxxxxxx_xxxxxxxx xxxxxxx_xxxxxxxx | (1) |
| 2g. Write Flash Page | 0110111_00000000 0110101_00000000 0110111_00000000 0110111_00000000 | xxxxxxx_xxxxxxxx xxxxxxx_xxxxxxxx xxxxxxx_xxxxxxxx xxxxxxx_xxxxxxxx | (1) |
| 2h. Poll for Page Write complete | 0110111_00000000 | xxxxx o x_xxxxxxxx | (2) |
| 3a. Enter Flash Read | 0100011_00000010 | xxxxxxx_xxxxxxxx | |
| 3b. Load Address High Byte | 0000111_aaaaaaa | xxxxxxx_xxxxxxxx | (9) |
| 3c. Load Address Low Byte | 0000011_bbbbbbbb | xxxxxxx_xxxxxxxx | |
| 3d. Read Data Low and High Byte | 0110010_00000000 0110110_00000000 0110111_00000000 | xxxxxxx_xxxxxxxx xxxxxxx_00000000 xxxxxxx_00000000 | low byte high byte |
| 4a. Enter EEPROM Write | 0100011_00010001 | xxxxxxx_xxxxxxxx | |
| 4b. Load Address High Byte | 0000111_aaaaaaa | xxxxxxx_xxxxxxxx | (9) |
| 4c. Load Address Low Byte | 0000011_bbbbbbbb | xxxxxxx_xxxxxxxx | |
| 4d. Load Data Byte | 0010011_iiiiiii | xxxxxxx_xxxxxxxx | |
| 4e. Latch Data | 0110111_00000000 1110111_00000000 0110111_00000000 | xxxxxxx_xxxxxxxx xxxxxxx_xxxxxxxx xxxxxxx_xxxxxxxx | (1) |
| 4f. Write EEPROM Page | 0110011_00000000 0110001_00000000 0110011_00000000 0110011_00000000 | xxxxxxx_xxxxxxxx xxxxxxx_xxxxxxxx xxxxxxx_xxxxxxxx xxxxxxx_xxxxxxxx | (1) |
| 4g. Poll for Page Write complete | 0110011_00000000 | xxxxx o x_xxxxxxxx | (2) |
| 5a. Enter EEPROM Read | 0100011_00000011 | xxxxxxx_xxxxxxxx | |
| 5b. Load Address High Byte | 0000111_aaaaaaa | xxxxxxx_xxxxxxxx | (9) |

Table 130. JTAG Programming Instruction (Continued)

Set (Continued) **a** = address high bits, **b** = address low bits, **H** = 0 - Low Byte, 1 - High Byte, **o** = data out, **i** = data in, **x** = don't care

| Instruction | TDI sequence | TDO sequence | Notes |
|--|--|--|-------|
| 5c. Load Address Low Byte | 0000011_ bbbbbbbb | xxxxxxx_xxxxxxxx | |
| 5d. Read Data Byte | 0110011_ bbbbbbbb 0110010_ 00000000 0110011_ 00000000 | xxxxxxx_xxxxxxxx xxxxxxx_xxxxxxxx xxxxxxx_ 00000000 | |
| 6a. Enter Fuse Write | 0100011_ 01000000 | xxxxxxx_xxxxxxxx | |
| 6b. Load Data Low Byte ⁽⁶⁾ | 0010011_ iiii | xxxxxxx_xxxxxxxx | (3) |
| 6c. Write Fuse Extended Byte | 0111011_ 00000000 0111001_ 00000000 0111011_ 00000000 0111011_ 00000000 | xxxxxxx_xxxxxxxx xxxxxxx_xxxxxxxx xxxxxxx_xxxxxxxx xxxxxxx_xxxxxxxx | (1) |
| 6d. Poll for Fuse Write complete | 0110111_ 00000000 | xxxxxox_xxxxxxxx | (2) |
| 6e. Load Data Low Byte ⁽⁷⁾ | 0010011_ iiii | xxxxxxx_xxxxxxxx | (3) |
| 6f. Write Fuse High Byte | 0110111_ 00000000 0110101_ 00000000 0110111_ 00000000 0110111_ 00000000 | xxxxxxx_xxxxxxxx xxxxxxx_xxxxxxxx xxxxxxx_xxxxxxxx xxxxxxx_xxxxxxxx | (1) |
| 6g. Poll for Fuse Write complete | 0110111_ 00000000 | xxxxxox_xxxxxxxx | (2) |
| 6h. Load Data Low Byte ⁽⁷⁾ | 0010011_ iiii | xxxxxxx_xxxxxxxx | (3) |
| 6i. Write Fuse Low Byte | 0110011_ 00000000 0110001_ 00000000 0110011_ 00000000 0110011_ 00000000 | xxxxxxx_xxxxxxxx xxxxxxx_xxxxxxxx xxxxxxx_xxxxxxxx xxxxxxx_xxxxxxxx | (1) |
| 6j. Poll for Fuse Write complete | 0110011_ 00000000 | xxxxxox_xxxxxxxx | (2) |
| 7a. Enter Lock bit Write | 0100011_ 00100000 | xxxxxxx_xxxxxxxx | |
| 7b. Load Data Byte ⁽⁹⁾ | 0010011_ 11iiii | xxxxxxx_xxxxxxxx | (4) |
| 7c. Write Lock bits | 0110011_ 00000000 0110001_ 00000000 0110011_ 00000000 0110011_ 00000000 | xxxxxxx_xxxxxxxx xxxxxxx_xxxxxxxx xxxxxxx_xxxxxxxx xxxxxxx_xxxxxxxx | (1) |
| 7d. Poll for Lock bit Write complete | 0110011_ 00000000 | xxxxxox_xxxxxxxx | (2) |
| 8a. Enter Fuse/Lock bit Read | 0100011_ 00000100 | xxxxxxx_xxxxxxxx | |
| 8b. Read Extended Fuse Byte ⁽⁶⁾ | 0111010_ 00000000 0111011_ 00000000 | xxxxxxx_xxxxxxxx xxxxxxx_ 00000000 | |
| 8c. Read Fuse High Byte ⁽⁷⁾ | 0111110_ 00000000 0111111_ 00000000 | xxxxxxx_xxxxxxxx xxxxxxx_ 00000000 | |
| 8d. Read Fuse Low Byte ⁽⁸⁾ | 0110010_ 00000000 0110011_ 00000000 | xxxxxxx_xxxxxxxx xxxxxxx_ 00000000 | |
| 8e. Read Lock bits ⁽⁹⁾ | 0110110_ 00000000 0110111_ 00000000 | xxxxxxx_xxxxxxxx xxxxxxx_x 00000000 | (5) |

Table 130. JTAG Programming Instruction (Continued)

Set (Continued) **a** = address high bits, **b** = address low bits, **H** = 0 - Low Byte, 1 - High Byte, **o** = data out, **i** = data in, **x** = don't care

| Instruction | TDI sequence | TDO sequence | Notes |
|----------------------------------|--|--|---|
| 8f. Read Fuses and Lock bits | 0111010_00000000 0111110_00000000 0110010_00000000 0110110_00000000 0110111_00000000 | xxxxxxx_xxxxxxxx xxxxxxx_00000000 xxxxxxx_00000000 xxxxxxx_00000000 xxxxxxx_00000000 | (5) fuse ext. byte fuse high byte fuse low byte lock bits |
| 9a. Enter Signature Byte Read | 0100011_00001000 | xxxxxxx_xxxxxxxx | |
| 9b. Load Address Byte | 0000011_ bbbbbbbb | xxxxxxx_xxxxxxxx | |
| 9c. Read Signature Byte | 0110010_00000000 0110011_00000000 | xxxxxxx_xxxxxxxx xxxxxxx_00000000 | |
| 10a. Enter Calibration Byte Read | 0100011_00001000 | xxxxxxx_xxxxxxxx | |
| 10b. Load Address Byte | 0000011_ bbbbbbbb | xxxxxxx_xxxxxxxx | |
| 10c. Read Calibration Byte | 0110110_00000000 0110111_00000000 | xxxxxxx_xxxxxxxx xxxxxxx_00000000 | |
| 11a. Load No Operation Command | 0100011_00000000 0110011_00000000 | xxxxxxx_xxxxxxxx xxxxxxx_xxxxxxxx | |

- Notes:
1. This command sequence is not required if the seven MSB are correctly set by the previous command sequence (which is normally the case).
 2. Repeat until o = "1".
 3. Set bits to "0" to program the corresponding fuse, "1" to unprogram the Fuse.
 4. Set bits to "0" to program the corresponding lock bit, "1" to leave the Lock bit unchanged.
 5. "0" = programmed, "1" = unprogrammed.
 6. The bit mapping for Fuses Extended Byte is listed in [Table 117 on page 287](#)
 7. The bit mapping for Fuses High Byte is listed in [Table 118 on page 288](#)
 8. The bit mapping for Fuses Low Byte is listed in [Table 119 on page 288](#)
 9. The bit mapping for Lock bits Byte is listed in [Table 115 on page 286](#)
 10. Address bits exceeding PCMSB and EEAMSB ([Table 123](#) and [Table 124](#)) are don't care

Figure 149. State Machine Sequence for Changing/Reading the Data Word

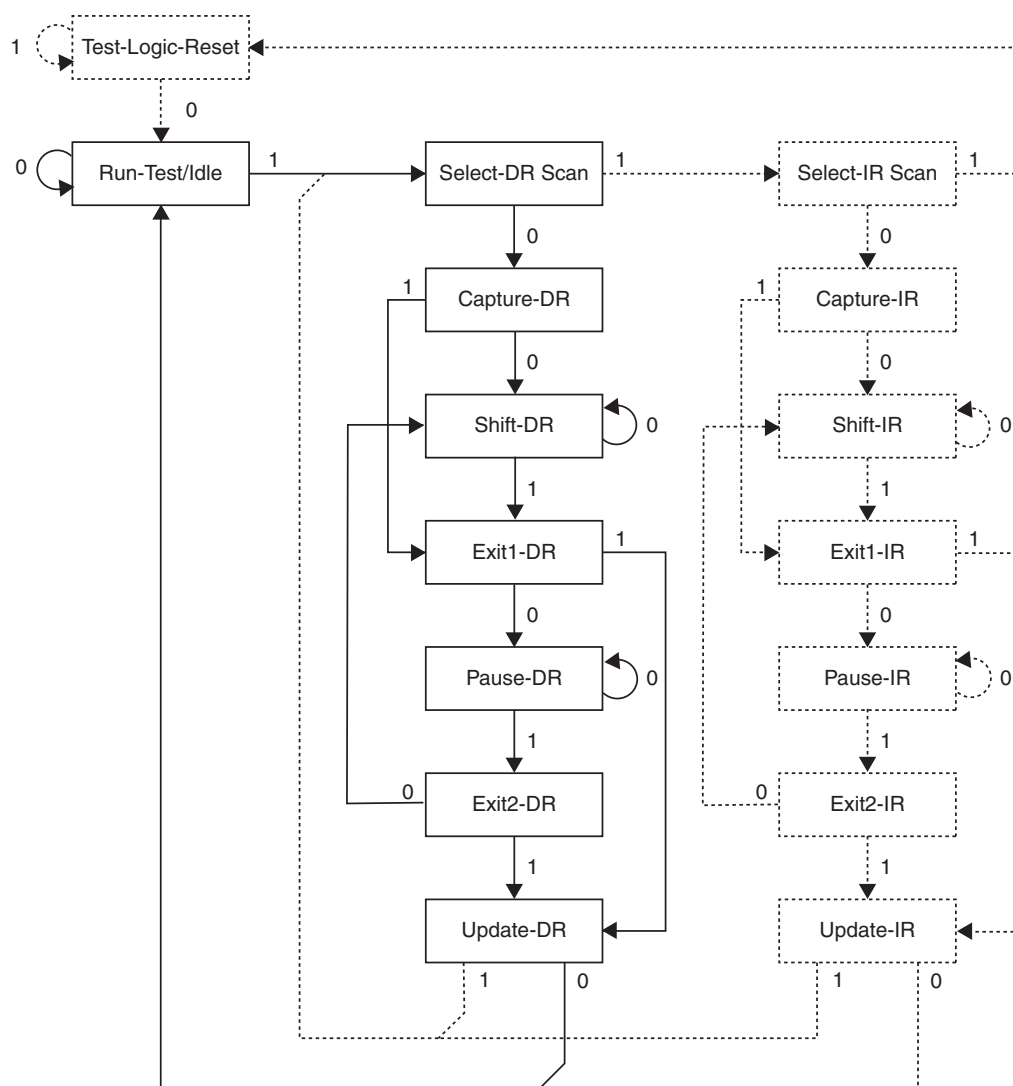

Virtual Flash Page Load Register

The Virtual Flash Page Load Register is a virtual scan chain with length equal to the number of bits in one Flash page. Internally the Shift Register is 8-bit, and the data are automatically transferred to the Flash page buffer byte by byte. Shift in all instruction words in the page, starting with the LSB of the first instruction in the page and ending with the MSB of the last instruction in the page. This provides an efficient way to load the entire Flash page buffer before executing Page Write.

Figure 150. Virtual Flash Page Load Register



Virtual Flash Page Read Register

The Virtual Flash Page Read Register is a virtual scan chain with length equal to the number of bits in one Flash page plus 8. Internally the Shift Register is 8-bit, and the data are automatically transferred from the Flash data page byte by byte. The first eight cycles are used to transfer the first byte to the internal Shift Register, and the bits that are shifted out during these 8 cycles should be ignored. Following this initialization, data are shifted out starting with the LSB of the first instruction in the page and ending with the MSB of the last instruction in the page. This provides an efficient way to read one full Flash page to verify programming.

Figure 151. Virtual Flash Page Read Register



Programming Algorithm

All references below of type “1a”, “1b”, and so on, refer to [Table 130](#).

- Entering Programming Mode**
1. Enter JTAG instruction AVR_RESET and shift 1 in the Reset Register.
 2. Enter instruction PROG_ENABLE and shift 1010_0011_0111_0000 in the Programming Enable Register.
- Leaving Programming Mode**
1. Enter JTAG instruction PROG_COMMANDS.
 2. Disable all programming instructions by using no operation instruction 11a.
 3. Enter instruction PROG_ENABLE and shift 0000_0000_0000_0000 in the programming Enable Register.
 4. Enter JTAG instruction AVR_RESET and shift 0 in the Reset Register.
- Performing Chip Erase**
1. Enter JTAG instruction PROG_COMMANDS.
 2. Start chip erase using programming instruction 1a.
 3. Poll for chip erase complete using programming instruction 1b, or wait for t_{WLRH_CE} (refer to [Table Note: on page 299](#)).
- Programming the Flash**
- Before programming the Flash a Chip Erase must be performed. See [“Performing Chip Erase” on page 315](#).
1. Enter JTAG instruction PROG_COMMANDS.
 2. Enable Flash write using programming instruction 2a.
 3. Load address high byte using programming instruction 2b.
 4. Load address low byte using programming instruction 2c.
 5. Load data using programming instructions 2d, 2e and 2f.
 6. Repeat steps 4 and 5 for all instruction words in the page.
 7. Write the page using programming instruction 2g.
 8. Poll for Flash write complete using programming instruction 2h, or wait for t_{WLRH} (refer to [Table Note: on page 299](#)).
 9. Repeat steps 3 to 7 until all data have been programmed.
- A more efficient data transfer can be achieved using the PROG_PAGELOAD instruction:
1. Enter JTAG instruction PROG_COMMANDS.
 2. Enable Flash write using programming instruction 2a.
 3. Load the page address using programming instructions 2b and 2c. PCWORD (refer to [Table 123 on page 291](#)) is used to address within one page and must be written as 0.
 4. Enter JTAG instruction PROG_PAGELOAD.
 5. Load the entire page by shifting in all instruction words in the page, starting with the LSB of the first instruction in the page and ending with the MSB of the last instruction in the page.
 6. Enter JTAG instruction PROG_COMMANDS.
 7. Write the page using programming instruction 2g.
 8. Poll for Flash write complete using programming instruction 2h, or wait for t_{WLRH} (refer to [Table Note: on page 299](#)).
 9. Repeat steps 3 to 8 until all data have been programmed.

Reading the Flash

1. Enter JTAG instruction PROG_COMMANDS.
2. Enable Flash read using programming instruction 3a.
3. Load address using programming instructions 3b and 3c.
4. Read data using programming instruction 3d.
5. Repeat steps 3 and 4 until all data have been read.

A more efficient data transfer can be achieved using the PROG_PAGEREAD instruction:

1. Enter JTAG instruction PROG_COMMANDS.
2. Enable Flash read using programming instruction 3a.
3. Load the page address using programming instructions 3b and 3c. PCWORD (refer to [Table 123 on page 291](#)) is used to address within one page and must be written as 0.
4. Enter JTAG instruction PROG_PAGEREAD.
5. Read the entire page by shifting out all instruction words in the page, starting with the LSB of the first instruction in the page and ending with the MSB of the last instruction in the page. Remember that the first 8 bits shifted out should be ignored.
6. Enter JTAG instruction PROG_COMMANDS.
7. Repeat steps 3 to 6 until all data have been read.

Programming the EEPROM

Before programming the EEPROM a Chip Erase must be performed. See [“Performing Chip Erase” on page 315](#).

1. Enter JTAG instruction PROG_COMMANDS.
2. Enable EEPROM write using programming instruction 4a.
3. Load address high byte using programming instruction 4b.
4. Load address low byte using programming instruction 4c.
5. Load data using programming instructions 4d and 4e.
6. Repeat steps 4 and 5 for all data bytes in the page.
7. Write the data using programming instruction 4f.
8. Poll for EEPROM write complete using programming instruction 4g, or wait for t_{WLRH} (refer to [Table Note: on page 299](#)).
9. Repeat steps 3 to 8 until all data have been programmed.

Note that the PROG_PAGELOAD instruction can not be used when programming the EEPROM

Reading the EEPROM

1. Enter JTAG instruction PROG_COMMANDS.
2. Enable EEPROM read using programming instruction 5a.
3. Load address using programming instructions 5b and 5c.
4. Read data using programming instruction 5d.
5. Repeat steps 3 and 4 until all data have been read.

Note that the PROG_PAGEREAD instruction can not be used when reading the EEPROM

Programming the Fuses

1. Enter JTAG instruction PROG_COMMANDS.
2. Enable Fuse write using programming instruction 6a.
3. Load data byte using programming instructions 6b. A bit value of “0” will program the corresponding fuse, a “1” will unprogram the fuse.
4. Write Extended Fuse byte using programming instruction 6c.
5. Poll for Fuse write complete using programming instruction 6d, or wait for t_{WLRH} (refer to [Table Note: on page 299](#)).
6. Load data byte using programming instructions 6e. A bit value of “0” will program the corresponding fuse, a “1” will unprogram the fuse.
7. Write Fuse high byte using programming instruction 6f.
8. Poll for Fuse write complete using programming instruction 6g, or wait for t_{WLRH} (refer to [Table Note: on page 299](#)).
9. Load data byte using programming instructions 6h. A “0” will program the fuse, a “1” will unprogram the fuse.
10. Write Fuse low byte using programming instruction 6i.
11. Poll for Fuse write complete using programming instruction 6j, or wait for t_{WLRH} (refer to [Table Note: on page 299](#)).

Programming the Lock Bits

1. Enter JTAG instruction PROG_COMMANDS.
2. Enable Lock bit write using programming instruction 7a.
3. Load data using programming instructions 7b. A bit value of “0” will program the corresponding lock bit, a “1” will leave the lock bit unchanged.
4. Write Lock bits using programming instruction 7c.
5. Poll for Lock bit write complete using programming instruction 7d, or wait for t_{WLRH} (refer to [Table Note: on page 299](#)).

Reading the Fuses and Lock Bits

1. Enter JTAG instruction PROG_COMMANDS.
2. Enable Fuse/Lock bit read using programming instruction 8a.
3. To read all Fuses and Lock bits, use programming instruction 8f.
To only read Extended Fuse byte, use programming instruction 8b.
To only read Fuse high byte, use programming instruction 8c.
To only read Fuse low byte, use programming instruction 8d.
To only read Lock bits, use programming instruction 8e.

Reading the Signature Bytes

1. Enter JTAG instruction PROG_COMMANDS.
2. Enable Signature byte read using programming instruction 9a.
3. Load address \$00 using programming instruction 9b.
4. Read first signature byte using programming instruction 9c.
5. Repeat steps 3 and 4 with address \$01 and address \$02 to read the second and third signature bytes, respectively.

Reading the Calibration Byte

1. Enter JTAG instruction PROG_COMMANDS.
2. Enable Calibration byte read using programming instruction 10a.
3. Load address \$00 using programming instruction 10b.
4. Read the calibration byte using programming instruction 10c.

Electrical Characteristics

Note: Typical values contained in this data sheet are based on simulations and characterization of other AVR microcontrollers manufactured on the same process technology. Min and Max values will be available after the device is characterized.

Absolute Maximum Ratings*

| | |
|--|------------------------|
| Operating Temperature | -55°C to +125°C |
| Storage Temperature | -65°C to +150°C |
| Voltage on any Pin except $\overline{\text{RESET}}$ with respect to Ground | -0.5V to $V_{CC}+0.5V$ |
| Voltage on $\overline{\text{RESET}}$ with respect to Ground..... | -0.5V to +13.0V |
| Maximum Operating Voltage | 6.0V |
| DC Current per I/O Pin | 40.0 mA |
| DC Current V_{CC} and GND Pins..... | 200.0 - 400.0mA |

*NOTICE: Stresses beyond those listed under “Absolute Maximum Ratings” may cause permanent damage to the device. This is a stress rating only and functional operation of the device at these or other conditions beyond those indicated in the operational sections of this specification is not implied. Exposure to absolute maximum rating conditions for extended periods may affect device reliability.

DC Characteristics

$T_A = -40^\circ\text{C}$ to 85°C , $V_{CC} = 2.7V$ to $5.5V$ (unless otherwise noted)

| Symbol | Parameter | Condition | Min | Typ | Max | Units |
|-----------|--|--|---------------------|-----|--------------------|------------|
| V_{IL} | Input Low Voltage except XTAL1 and $\overline{\text{RESET}}$ pins | $V_{CC} = 2.7V - 5.5V$ | -0.5 | | $0.2 V_{CC}^{(1)}$ | V |
| V_{IH} | Input High Voltage except XTAL1 and $\overline{\text{RESET}}$ pins | $V_{CC} = 2.7V - 5.5V$ | $0.6 V_{CC}^{(2)}$ | | $V_{CC} + 0.5$ | |
| V_{IL1} | Input Low Voltage XTAL1 pin | $V_{CC} = 2.7V - 5.5V$ | -0.5 | | $0.1 V_{CC}^{(1)}$ | |
| V_{IH1} | Input High Voltage XTAL1 pin | $V_{CC} = 2.7V - 5.5V$ | $0.7 V_{CC}^{(2)}$ | | $V_{CC} + 0.5$ | |
| V_{IL2} | Input Low Voltage $\overline{\text{RESET}}$ pin | $V_{CC} = 2.7V - 5.5V$ | -0.5 | | $0.2 V_{CC}^{(1)}$ | |
| V_{IH2} | Input High Voltage $\overline{\text{RESET}}$ pin | $V_{CC} = 2.7V - 5.5V$ | $0.85 V_{CC}^{(2)}$ | | $V_{CC} + 0.5$ | |
| V_{OL} | Output Low Voltage ⁽³⁾ (Ports A,B,C,D, E, F, G) | $I_{OL} = 20mA, V_{CC} = 5V$ $I_{OL} = 10mA, V_{CC} = 3V$ | | | 0.7 0.5 | V V |
| V_{OH} | Output High Voltage ⁽⁴⁾ (Ports A,B,C,D, E, F, G) | $I_{OH} = -20mA, V_{CC} = 5V$ $I_{OH} = -10mA, V_{CC} = 3V$ | 4.2 2.2 | | | V V |
| I_{IL} | Input Leakage Current I/O Pin | $V_{CC} = 5.5V$, pin low (absolute value) | | | 1.0 | μA |
| I_{IH} | Input Leakage Current I/O Pin | $V_{CC} = 5.5V$, pin high (absolute value) | | | 1.0 | |
| R_{RST} | Reset Pull-up Resistor | | 30 | | 85 | k Ω |
| R_{PEN} | PEN Pull-up Resistor | | 30 | | 60 | |
| R_{PU} | I/O Pin Pull-up Resistor | | 20 | | 50 | |

$T_A = -40^{\circ}\text{C}$ to 85°C , $V_{CC} = 2.7\text{V}$ to 5.5V (unless otherwise noted) (Continued)

| Symbol | Parameter | Condition | Min | Typ | Max | Units |
|------------|--|---|-----|------------|-----|---------------|
| I_{CC} | Power Supply Current | Active 4MHz, $V_{CC} = 3\text{V}$ (ATmega128L) | | 5 | 5.5 | mA |
| | | Active 8MHz, $V_{CC} = 5\text{V}$ (ATmega128) | | 17 | 19 | |
| | | Idle 4MHz, $V_{CC} = 3\text{V}$ (ATmega128L) | | 2 | 2.5 | |
| | | Idle 8MHz, $V_{CC} = 5\text{V}$ (ATmega128) | | 8 | 11 | |
| | Power-down mode | WDT enabled, $V_{CC} = 3\text{V}$ | | < 15 | 25 | μA |
| | | WDT disabled, $V_{CC} = 3\text{V}$ | | < 5 | 10 | |
| V_{ACIO} | Analog Comparator Input Offset Voltage | $V_{CC} = 5\text{V}$ $V_{in} = V_{CC}/2$ | | | 40 | mV |
| I_{ACLK} | Analog Comparator Input Leakage Current | $V_{CC} = 5\text{V}$ $V_{in} = V_{CC}/2$ | -50 | | 50 | nA |
| t_{ACPD} | Analog Comparator Propagation Delay | $V_{CC} = 2.7\text{V}$ $V_{CC} = 5.0\text{V}$ | | 750 500 | | ns |

- Notes:
1. "Max" means the highest value where the pin is guaranteed to be read as low
 2. "Min" means the lowest value where the pin is guaranteed to be read as high
 3. Although each I/O port can sink more than the test conditions (20mA at $V_{CC} = 5\text{V}$, 10mA at $V_{CC} = 3\text{V}$) under steady state conditions (non-transient), the following must be observed:
TQFP and QFN/MLF Package:
 - 1] The sum of all IOL, for all ports, should not exceed 400mA.
 - 2] The sum of all IOL, for ports A0 - A7, G2, C3 - C7 should not exceed 100mA.
 - 3] The sum of all IOL, for ports C0 - C2, G0 - G1, D0 - D7, XTAL2 should not exceed 100mA.
 - 4] The sum of all IOL, for ports B0 - B7, G3 - G4, E0 - E7 should not exceed 100mA.
 - 5] The sum of all IOL, for ports F0 - F7, should not exceed 100mA.
 If IOL exceeds the test condition, VOL may exceed the related specification. Pins are not guaranteed to sink current greater than the listed test condition.
 4. Although each I/O port can source more than the test conditions (20mA at $V_{CC} = 5\text{V}$, 10mA at $V_{CC} = 3\text{V}$) under steady state conditions (non-transient), the following must be observed:
TQFP and QFN/MLF Package:
 - 1] The sum of all IOH, for all ports, should not exceed 400mA.
 - 2] The sum of all IOH, for ports A0 - A7, G2, C3 - C7 should not exceed 100mA.
 - 3] The sum of all IOH, for ports C0 - C2, G0 - G1, D0 - D7, XTAL2 should not exceed 100mA.
 - 4] The sum of all IOH, for ports B0 - B7, G3 - G4, E0 - E7 should not exceed 100mA.
 - 5] The sum of all IOH, for ports F0 - F7, should not exceed 100mA.
 If IOH exceeds the test condition, VOH may exceed the related specification. Pins are not guaranteed to source current greater than the listed test condition.

Speed Grades

Figure 152. Maximum frequency vs. V_{CC}



External Clock Drive Waveforms

Figure 153. External Clock Drive Waveforms

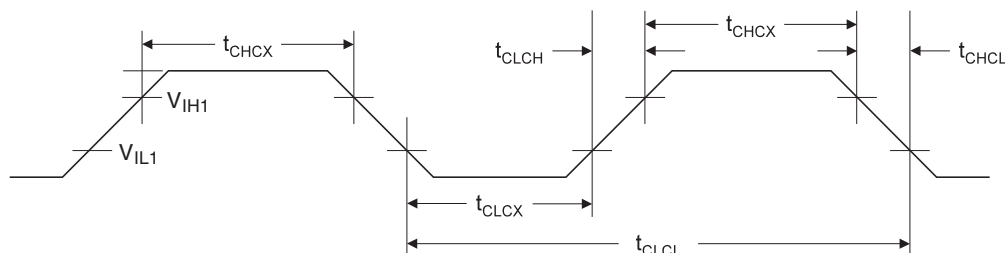

External Clock Drive

Table 131. External Clock Drive

| Symbol | Parameter | $V_{CC} = 2.7V \text{ to } 5.5V$ | | $V_{CC} = 4.5V \text{ to } 5.5V$ | | Units |
|-------------------|---|----------------------------------|-----|----------------------------------|-----|---------|
| | | Min | Max | Min | Max | |
| $1/t_{CLCL}$ | Oscillator Frequency | 0 | 8 | 0 | 16 | MHz |
| t_{CLCL} | Clock Period | 125 | | 62.5 | | ns |
| t_{CHCX} | High Time | 50 | | 25 | | ns |
| t_{CLCX} | Low Time | 50 | | 25 | | ns |
| t_{CLCH} | Rise Time | | 1.6 | | 0.5 | μs |
| t_{CHCL} | Fall Time | | 1.6 | | 0.5 | μs |
| Δt_{CLCL} | Change in period from one clock cycle to the next | | 2 | | 2 | % |

Table 132. External RC Oscillator, Typical Frequencies

| R [kΩ] ⁽¹⁾ | C [pF] | f ⁽²⁾ |
|-----------------------|--------|------------------|
| 33 | 22 | 650kHz |
| 10 | 22 | 2.0MHz |

- Notes:
1. R should be in the range 3kΩ - 100kΩ, and C should be at least 20pF. The C values given in the table includes pin capacitance. This will vary with package type.
 2. The frequency will vary with package type and board layout.

Two-wire Serial Interface Characteristics

Table 133 describes the requirements for devices connected to the Two-wire Serial Bus. The ATmega128 Two-wire Serial Interface meets or exceeds these requirements under the noted conditions.

Timing symbols refer to Figure 154.

Table 133. Two-wire Serial Bus Requirements

| Symbol | Parameter | Condition | Min | Max | Units |
|-----------------|--|--|-----------------------------|----------------------|----------|
| V_{IL} | Input Low-voltage | | -0.5 | $0.3 V_{CC}$ | V |
| V_{IH} | Input High-voltage | | $0.7 V_{CC}$ | $V_{CC} + 0.5$ | |
| $V_{hys}^{(1)}$ | Hysteresis of Schmitt Trigger Inputs | | $0.05 V_{CC}^{(2)}$ | – | |
| $V_{OL}^{(1)}$ | Output Low-voltage | 3mA sink current | 0 | 0.4 | ns |
| $t_r^{(1)}$ | Rise Time for both SDA and SCL | | $20 + 0.1C_b^{(3)(2)}$ | 300 | |
| $t_{of}^{(1)}$ | Output Fall Time from V_{IHmin} to V_{ILmax} | $10pF < C_b < 400pF^{(3)}$ | $20 + 0.1C_b^{(3)(2)}$ | 250 | |
| $t_{SP}^{(1)}$ | Spikes Suppressed by Input Filter | | 0 | $50^{(2)}$ | μA |
| I_i | Input Current each I/O Pin | $0.1 V_{CC} < V_i < 0.9 V_{CC}$ | -10 | 10 | |
| $C_i^{(1)}$ | Capacitance for each I/O Pin | | – | 10 | |
| f_{SCL} | SCL Clock Frequency | $f_{CK}^{(4)} > \max(16f_{SCL}, 250kHz)^{(5)}$ | 0 | 400 | kHz |
| Rp | Value of Pull-up resistor | $f_{SCL} \leq 100kHz$ | $\frac{V_{CC} - 0.4V}{3mA}$ | $\frac{1000ns}{C_b}$ | Ω |
| | | $f_{SCL} > 100kHz$ | $\frac{V_{CC} - 0.4V}{3mA}$ | $\frac{300ns}{C_b}$ | Ω |
| $t_{HD;STA}$ | Hold Time (repeated) START Condition | $f_{SCL} \leq 100kHz$ | 4.0 | – | μs |
| | | $f_{SCL} > 100kHz$ | 0.6 | – | |
| t_{LOW} | Low Period of the SCL Clock | $f_{SCL} \leq 100kHz$ | 4.7 | – | |
| | | $f_{SCL} > 100kHz$ | 1.3 | – | |
| t_{HIGH} | High period of the SCL clock | $f_{SCL} \leq 100kHz$ | 4.0 | – | |
| | | $f_{SCL} > 100kHz$ | 0.6 | – | |
| $t_{SU;STA}$ | Set-up time for a repeated START condition | $f_{SCL} \leq 100kHz$ | 4.7 | – | |
| | | $f_{SCL} > 100kHz$ | 0.6 | – | |
| $t_{HD;DAT}$ | Data hold time | $f_{SCL} \leq 100kHz$ | 0 | 3.45 | |
| | | $f_{SCL} > 100kHz$ | 0 | 0.9 | |
| $t_{SU;DAT}$ | Data setup time | $f_{SCL} \leq 100kHz$ | 250 | – | ns |
| | | $f_{SCL} > 100kHz$ | 100 | – | |
| $t_{SU;STO}$ | Setup time for STOP condition | $f_{SCL} \leq 100kHz$ | 4.0 | – | μs |
| | | $f_{SCL} > 100kHz$ | 0.6 | – | |
| t_{BUF} | Bus free time between a STOP and START condition | $f_{SCL} \leq 100kHz$ | 4.7 | – | |

- Notes:
1. In ATmega128, this parameter is characterized and not 100% tested.
 2. Required only for $f_{SCL} > 100kHz$.
 3. C_b = capacitance of one bus line in pF.
 4. f_{CK} = CPU clock frequency

5. This requirement applies to all Atmel® AVR® ATmega128 Two-wire Serial Interface operation. Other devices connected to the Two-wire Serial Bus need only obey the general f_{SCL} requirement.

Figure 154. Two-wire Serial Bus Timing



SPI Timing Characteristics

See [Figure 155](#) and [Figure 156](#) for details.

Table 134. SPI Timing Parameters

| | Description | Mode | Min | Typ | Max | |
|----|-----------------------------------|--------|------------------|------------------------------|-----|---------|
| 1 | SCK period | Master | | See Table 72 | | ns |
| 2 | SCK high/low | Master | | 50% duty cycle | | |
| 3 | Rise/Fall time | Master | | 3.6 | | |
| 4 | Setup | Master | | 10 | | |
| 5 | Hold | Master | | 10 | | |
| 6 | Out to SCK | Master | | $0.5 \cdot t_{sck}$ | | |
| 7 | SCK to out | Master | | 10 | | |
| 8 | SCK to out high | Master | | 10 | | |
| 9 | SS low to out | Slave | | 15 | | |
| 10 | SCK period | Slave | $4 \cdot t_{ck}$ | | | |
| 11 | SCK high/low ⁽¹⁾ | Slave | $2 \cdot t_{ck}$ | | | |
| 12 | Rise/Fall time | Slave | | | 1.6 | μ s |
| 13 | Setup | Slave | 10 | | | ns |
| 14 | Hold | Slave | 10 | | | |
| 15 | SCK to out | Slave | | 15 | | |
| 16 | SCK to \overline{SS} high | Slave | 20 | | | |
| 17 | \overline{SS} high to tri-state | Slave | | 10 | | |
| 18 | \overline{SS} low to SCK | Slave | $2 \cdot t_{ck}$ | | | |

Note: 1. In SPI Programming mode the minimum SCK high/low period is:
 - $2 \cdot t_{CLCL}$ for $f_{CK} < 12\text{MHz}$
 - $3 \cdot t_{CLCL}$ for $f_{CK} > 12\text{MHz}$

Figure 155. SPI Interface Timing Requirements (Master Mode)



Figure 156. SPI Interface Timing Requirements (Slave Mode)

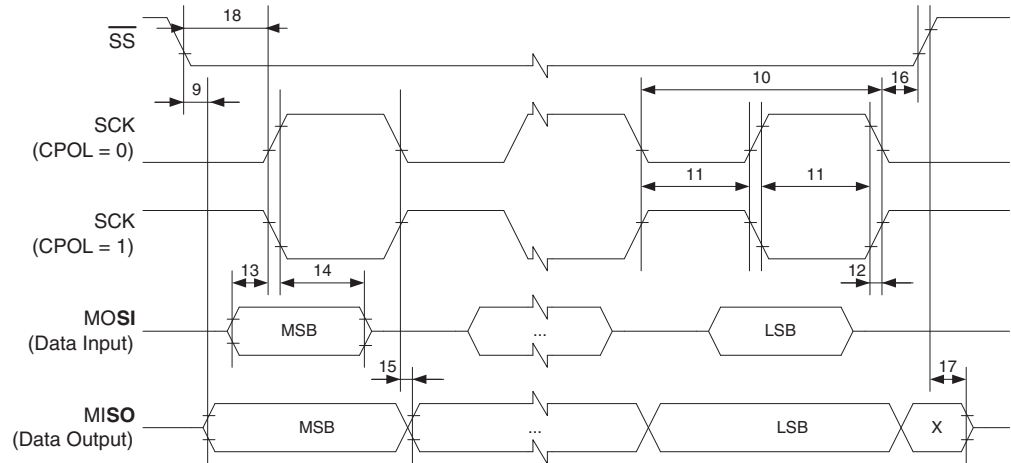

ADC Characteristics

Table 135. ADC Characteristics, Single Ended Channels

| Symbol | Parameter | Condition | Min ⁽¹⁾ | Typ ⁽¹⁾ | Max ⁽¹⁾ | Units |
|-----------|--|--|----------------------|--------------------|----------------------|-------|
| | Resolution | Single Ended Conversion | | | 10 | Bits |
| | Absolute Accuracy (Including INL, DNL, Quantization Error, Gain and Offset Error) | Single Ended Conversion $V_{REF} = 4V, V_{CC} = 4V$ ADC clock = 200kHz | | 1.5 | | LSB |
| | | Single Ended Conversion $V_{REF} = 4V, V_{CC} = 4V$ ADC clock = 1MHz | | 3.25 | | |
| | | Single Ended Conversion $V_{REF} = 4V, V_{CC} = 4V$ ADC clock = 200kHz Noise Reduction mode | | 1.5 | | |
| | | Single Ended Conversion $V_{REF} = 4V, V_{CC} = 4V$ ADC clock = 1MHz Noise Reduction mode | | 3.75 | | |
| | Integral Non-Linearity (INL) | Single Ended Conversion $V_{REF} = 4V, V_{CC} = 4V$ ADC clock = 200kHz | | 0.75 | | |
| | Differential Non-Linearity (DNL) | Single Ended Conversion $V_{REF} = 4V, V_{CC} = 4V$ ADC clock = 200kHz | | 0.5 | | |
| | Gain Error | Single Ended Conversion $V_{REF} = 4V, V_{CC} = 4V$ ADC clock = 200kHz | | 1 | | |
| | Offset error | Single Ended Conversion $V_{REF} = 4V, V_{CC} = 4V$ ADC clock = 200kHz | | 1 | | |
| | Clock Frequency | | 50 | | 1000 | kHz |
| | Conversion Time | | 13 | | 260 | μs |
| AVCC | Analog Supply Voltage | | $V_{CC} - 0.3^{(2)}$ | | $V_{CC} + 0.3^{(3)}$ | V |
| V_{REF} | Reference Voltage | | 2.0 | | AVCC | |
| V_{IN} | Input Voltage | | GND | | V_{REF} | |
| | Input Bandwidth | | | | 38.5 | kHz |
| V_{INT} | Internal Voltage Reference | | 2.3 | 2.56 | 2.7 | V |
| R_{REF} | Reference Input Resistance | | | 32 | | kΩ |
| R_{AIN} | Analog Input Resistance | | 55 | 100 | | MΩ |

- Notes:
1. Values are guidelines only.
 2. Minimum for AVCC is 2.7V.
 3. Maximum for AVCC is 5.5V

Table 136. ADC Characteristics, Differential Channels

| Symbol | Parameter | Condition | Min ⁽¹⁾ | Typ ⁽¹⁾ | Max ⁽¹⁾ | Units |
|------------|--|---|----------------------|--------------------|----------------------|-------|
| | Resolution | Gain = 1x | | | 10 | Bits |
| | | Gain = 10x | | | 10 | |
| | | Gain = 200x | | | 10 | |
| | Absolute Accuracy | Gain = 1x $V_{REF} = 4V, V_{CC} = 5V$ ADC clock = 50 - 200kHz | | 17 | | LSB |
| | | Gain = 10x $V_{REF} = 4V, V_{CC} = 5V$ ADC clock = 50 - 200kHz | | 17 | | |
| | | Gain = 200x $V_{REF} = 4V, V_{CC} = 5V$ ADC clock = 50 - 200kHz | | 7 | | |
| | Integral Non-Linearity (INL) (Accuracy after Calibration for Offset and Gain Error) | Gain = 1x $V_{REF} = 4V, V_{CC} = 5V$ ADC clock = 50 - 200kHz | | 1.5 | | LSB |
| | | Gain = 10x $V_{REF} = 4V, V_{CC} = 5V$ ADC clock = 50 - 200kHz | | 2 | | |
| | | Gain = 200x $V_{REF} = 4V, V_{CC} = 5V$ ADC clock = 50 - 200kHz | | 5 | | |
| | Gain Error | Gain = 1x | | 1.5 | | % |
| | | Gain = 10x | | 1.5 | | |
| | | Gain = 200x | | 0.5 | | |
| | Offset Error | Gain = 1x $V_{REF} = 4V, V_{CC} = 5V$ ADC clock = 50 - 200kHz | | 2 | | LSB |
| | | Gain = 10x $V_{REF} = 4V, V_{CC} = 5V$ ADC clock = 50 - 200kHz | | 3 | | |
| | | Gain = 200x $V_{REF} = 4V, V_{CC} = 5V$ ADC clock = 50 - 200kHz | | 4 | | |
| | Clock Frequency | | 50 | | 200 | kHz |
| | Conversion Time | | 65 | | 260 | μs |
| AVCC | Analog Supply Voltage | | $V_{CC} - 0.3^{(2)}$ | | $V_{CC} + 0.3^{(3)}$ | V |
| V_{REF} | Reference Voltage | | 2.0 | | AVCC - 0.5 | |
| V_{IN} | Input Voltage | | GND | | V_{CC} | |
| V_{DIFF} | Input Differential Voltage | | $-V_{REF}/Gain$ | | $V_{REF}/Gain$ | |
| | ADC Conversion Output | | -511 | | 511 | LSB |
| | Input Bandwidth | | | 4 | | kHz |

Table 136. ADC Characteristics, Differential Channels (Continued)

| Symbol | Parameter | Condition | Min ⁽¹⁾ | Typ ⁽¹⁾ | Max ⁽¹⁾ | Units |
|------------------|----------------------------|-----------|--------------------|--------------------|--------------------|-------|
| V _{INT} | Internal Voltage Reference | | 2.3 | 2.56 | 2.7 | V |
| R _{REF} | Reference Input Resistance | | | 32 | | kΩ |
| R _{AIN} | Analog Input Resistance | | 55 | 100 | | MΩ |

- Notes:
1. Values are guidelines only.
 2. Minimum for AVCC is 2.7V.
 3. Maximum for AVCC is 5.5V.

External Data Memory Timing

Table 137. External Data Memory Characteristics, 4.5 - 5.5 Volts, No Wait-state

| | Symbol | Parameter | 8MHz Oscillator | | Variable Oscillator | | Unit |
|----|----------------|--|-----------------|------|------------------------|-----------------------|------|
| | | | Min | Max | Min | Max | |
| 0 | $1/t_{CLCL}$ | Oscillator Frequency | | | 0.0 | 16 | MHz |
| 1 | t_{LHLL} | ALE Pulse Width | 115 | | $1.0t_{CLCL}-10$ | | ns |
| 2 | t_{AVLL} | Address Valid A to ALE Low | 57.5 | | $0.5t_{CLCL}-5^{(1)}$ | | |
| 3a | t_{LLAX_ST} | Address Hold After ALE Low, write access | 5 | | 5 | | |
| 3b | t_{LLAX_LD} | Address Hold after ALE Low, read access | 5 | | 5 | | |
| 4 | t_{AVLLC} | Address Valid C to ALE Low | 57.5 | | $0.5t_{CLCL}-5^{(1)}$ | | |
| 5 | t_{AVRL} | Address Valid to RD Low | 115 | | $1.0t_{CLCL}-10$ | | |
| 6 | t_{AVWL} | Address Valid to WR Low | 115 | | $1.0t_{CLCL}-10$ | | |
| 7 | t_{LLWL} | ALE Low to WR Low | 47.5 | 67.5 | $0.5t_{CLCL}-15^{(2)}$ | $0.5t_{CLCL}+5^{(2)}$ | |
| 8 | t_{LLRL} | ALE Low to RD Low | 47.5 | 67.5 | $0.5t_{CLCL}-15^{(2)}$ | $0.5t_{CLCL}+5^{(2)}$ | |
| 9 | t_{DVRH} | Data Setup to RD High | 40 | | 40 | | |
| 10 | t_{RLDV} | Read Low to Data Valid | | 75 | | $1.0t_{CLCL}-50$ | |
| 11 | t_{RHDX} | Data Hold After RD High | 0 | | 0 | | |
| 12 | t_{RLRH} | RD Pulse Width | 115 | | $1.0t_{CLCL}-10$ | | |
| 13 | t_{DVWL} | Data Setup to WR Low | 42.5 | | $0.5t_{CLCL}-20^{(1)}$ | | |
| 14 | t_{WHDX} | Data Hold After WR High | 115 | | $1.0t_{CLCL}-10$ | | |
| 15 | t_{DVWH} | Data Valid to WR High | 125 | | $1.0t_{CLCL}$ | | |
| 16 | t_{WLWH} | WR Pulse Width | 115 | | $1.0t_{CLCL}-10$ | | |

Notes: 1. This assumes 50% clock duty cycle. The half period is actually the high time of the external clock, XTAL1.
 2. This assumes 50% clock duty cycle. The half period is actually the low time of the external clock, XTAL1.

Table 138. External Data Memory Characteristics, 4.5 - 5.5V, 1 Cycle Wait-state

| | Symbol | Parameter | 8MHz Oscillator | | Variable Oscillator | | Unit |
|----|--------------|------------------------|-----------------|-----|---------------------|------------------|------|
| | | | Min | Max | Min | Max | |
| 0 | $1/t_{CLCL}$ | Oscillator Frequency | | | 0.0 | 16 | MHz |
| 10 | t_{RLDV} | Read Low to Data Valid | | 200 | | $2.0t_{CLCL}-50$ | ns |
| 12 | t_{RLRH} | RD Pulse Width | 240 | | $2.0t_{CLCL}-10$ | | |
| 15 | t_{DVWH} | Data Valid to WR High | 240 | | $2.0t_{CLCL}$ | | |
| 16 | t_{WLWH} | WR Pulse Width | 240 | | $2.0t_{CLCL}-10$ | | |

Table 139. External Data Memory Characteristics, 4.5 - 5.5V, SRWn1 = 1, SRWn0 = 0

| | Symbol | Parameter | 4MHz Oscillator | | Variable Oscillator | | Unit |
|----|--------------|------------------------|-----------------|-----|---------------------|------------------|------|
| | | | Min | Max | Min | Max | |
| 0 | $1/t_{CLCL}$ | Oscillator Frequency | | | 0.0 | 16 | MHz |
| 10 | t_{RLDV} | Read Low to Data Valid | | 325 | | $3.0t_{CLCL}-50$ | ns |
| 12 | t_{RLRH} | RD Pulse Width | 365 | | $3.0t_{CLCL}-10$ | | |
| 15 | t_{DVWH} | Data Valid to WR High | 375 | | $3.0t_{CLCL}$ | | |
| 16 | t_{WLWH} | WR Pulse Width | 365 | | $3.0t_{CLCL}-10$ | | |

Table 140. External Data Memory Characteristics, 4.5 - 5.5 Volts, SRWn1 = 1, SRWn0 = 1

| | Symbol | Parameter | 4MHz Oscillator | | Variable Oscillator | | Unit |
|----|--------------|-------------------------|-----------------|-----|---------------------|------------------|------|
| | | | Min | Max | Min | Max | |
| 0 | $1/t_{CLCL}$ | Oscillator Frequency | | | 0.0 | 16 | MHz |
| 10 | t_{RLDV} | Read Low to Data Valid | | 325 | | $3.0t_{CLCL}-50$ | ns |
| 12 | t_{RLRH} | RD Pulse Width | 365 | | $3.0t_{CLCL}-10$ | | |
| 14 | t_{WHDX} | Data Hold After WR High | 240 | | $2.0t_{CLCL}-10$ | | |
| 15 | t_{DVWH} | Data Valid to WR High | 375 | | $3.0t_{CLCL}$ | | |
| 16 | t_{WLWH} | WR Pulse Width | 365 | | $3.0t_{CLCL}-10$ | | |

Table 141. External Data Memory Characteristics, 2.7 - 5.5V, No Wait-state

| | Symbol | Parameter | 4MHz Oscillator | | Variable Oscillator | | Unit |
|----|----------------|--|-----------------|-----|------------------------|-----------------------|------|
| | | | Min | Max | Min | Max | |
| 0 | $1/t_{CLCL}$ | Oscillator Frequency | | | 0.0 | 8 | MHz |
| 1 | t_{LHLL} | ALE Pulse Width | 235 | | $t_{CLCL}-15$ | | ns |
| 2 | t_{AVLL} | Address Valid A to ALE Low | 115 | | $0.5t_{CLCL}-10^{(1)}$ | | |
| 3a | t_{LLAX_ST} | Address Hold After ALE Low, write access | 5 | | 5 | | |
| 3b | t_{LLAX_LD} | Address Hold after ALE Low, read access | 5 | | 5 | | |
| 4 | t_{AVLLC} | Address Valid C to ALE Low | 115 | | $0.5t_{CLCL}-10^{(1)}$ | | |
| 5 | t_{AVRL} | Address Valid to RD Low | 235 | | $1.0t_{CLCL}-15$ | | |
| 6 | t_{AVWL} | Address Valid to WR Low | 235 | | $1.0t_{CLCL}-15$ | | |
| 7 | t_{LLWL} | ALE Low to WR Low | 115 | 130 | $0.5t_{CLCL}-10^{(2)}$ | $0.5t_{CLCL}+5^{(2)}$ | |
| 8 | t_{LLRL} | ALE Low to RD Low | 115 | 130 | $0.5t_{CLCL}-10^{(2)}$ | $0.5t_{CLCL}+5^{(2)}$ | |
| 9 | t_{DVRH} | Data Setup to RD High | 45 | | 45 | | |
| 10 | t_{RLDV} | Read Low to Data Valid | | 190 | | $1.0t_{CLCL}-60$ | |
| 11 | t_{RHDX} | Data Hold After RD High | 0 | | 0 | | |

Table 141. External Data Memory Characteristics, 2.7 - 5.5V, No Wait-state (Continued)

| | Symbol | Parameter | 4MHz Oscillator | | Variable Oscillator | | Unit |
|----|------------|-------------------------|-----------------|-----|------------------------|-----|------|
| | | | Min | Max | Min | Max | |
| 12 | t_{RLRH} | RD Pulse Width | 235 | | $1.0t_{CLCL}-15$ | | ns |
| 13 | t_{DVWL} | Data Setup to WR Low | 105 | | $0.5t_{CLCL}-20^{(1)}$ | | |
| 14 | t_{WHDX} | Data Hold After WR High | 235 | | $1.0t_{CLCL}-15$ | | |
| 15 | t_{DVWH} | Data Valid to WR High | 250 | | $1.0t_{CLCL}$ | | |
| 16 | t_{WLWH} | WR Pulse Width | 235 | | $1.0t_{CLCL}-15$ | | |

Notes: 1. This assumes 50% clock duty cycle. The half period is actually the high time of the external clock, XTAL1.
 2. This assumes 50% clock duty cycle. The half period is actually the low time of the external clock, XTAL1.

Table 142. External Data Memory Characteristics, 2.7 - 5.5V, SRWn1 = 0, SRWn0 = 1

| | Symbol | Parameter | 4MHz Oscillator | | Variable Oscillator | | Unit |
|----|--------------|------------------------|-----------------|-----|---------------------|------------------|------|
| | | | Min | Max | Min | Max | |
| 0 | $1/t_{CLCL}$ | Oscillator Frequency | | | 0.0 | 8 | MHz |
| 10 | t_{RLDV} | Read Low to Data Valid | | 440 | | $2.0t_{CLCL}-60$ | ns |
| 12 | t_{RLRH} | RD Pulse Width | 485 | | $2.0t_{CLCL}-15$ | | |
| 15 | t_{DVWH} | Data Valid to WR High | 500 | | $2.0t_{CLCL}$ | | |
| 16 | t_{WLWH} | WR Pulse Width | 485 | | $2.0t_{CLCL}-15$ | | |

Table 143. External Data Memory Characteristics, 2.7 - 5.5V, SRWn1 = 1, SRWn0 = 0

| | Symbol | Parameter | 4MHz Oscillator | | Variable Oscillator | | Unit |
|----|--------------|------------------------|-----------------|-----|---------------------|------------------|------|
| | | | Min | Max | Min | Max | |
| 0 | $1/t_{CLCL}$ | Oscillator Frequency | | | 0.0 | 8 | MHz |
| 10 | t_{RLDV} | Read Low to Data Valid | | 690 | | $3.0t_{CLCL}-60$ | ns |
| 12 | t_{RLRH} | RD Pulse Width | 735 | | $3.0t_{CLCL}-15$ | | |
| 15 | t_{DVWH} | Data Valid to WR High | 750 | | $3.0t_{CLCL}$ | | |
| 16 | t_{WLWH} | WR Pulse Width | 735 | | $3.0t_{CLCL}-15$ | | |

Table 144. External Data Memory Characteristics, 2.7 - 5.5V, SRWn1 = 1, SRWn0 = 1

| | Symbol | Parameter | 4MHz Oscillator | | Variable Oscillator | | Unit |
|----|--------------|-------------------------|-----------------|-----|---------------------|------------------|------|
| | | | Min | Max | Min | Max | |
| 0 | $1/t_{CLCL}$ | Oscillator Frequency | | | 0.0 | 8 | MHz |
| 10 | t_{RLDV} | Read Low to Data Valid | | 690 | | $3.0t_{CLCL}-60$ | ns |
| 12 | t_{RLRH} | RD Pulse Width | 735 | | $3.0t_{CLCL}-15$ | | |
| 14 | t_{WHDX} | Data Hold After WR High | 485 | | $2.0t_{CLCL}-15$ | | |
| 15 | t_{DVWH} | Data Valid to WR High | 750 | | $3.0t_{CLCL}$ | | |
| 16 | t_{WLWH} | WR Pulse Width | 735 | | $3.0t_{CLCL}-15$ | | |

Figure 157. External Memory Timing (SRWn1 = 0, SRWn0 = 0)



Figure 158. External Memory Timing (SRWn1 = 0, SRWn0 = 1)

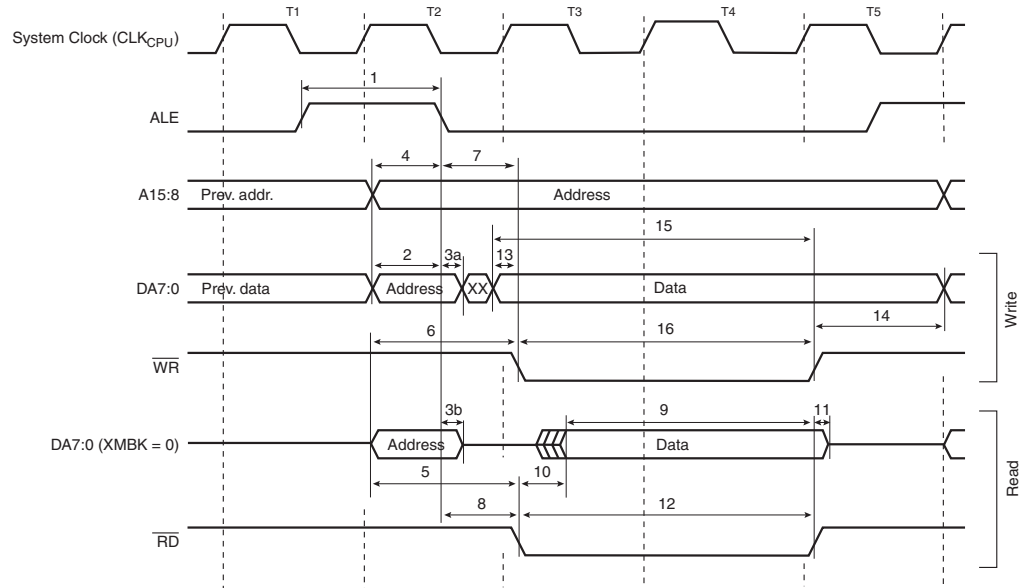

Figure 159. External Memory Timing (SRWn1 = 1, SRWn0 = 0)

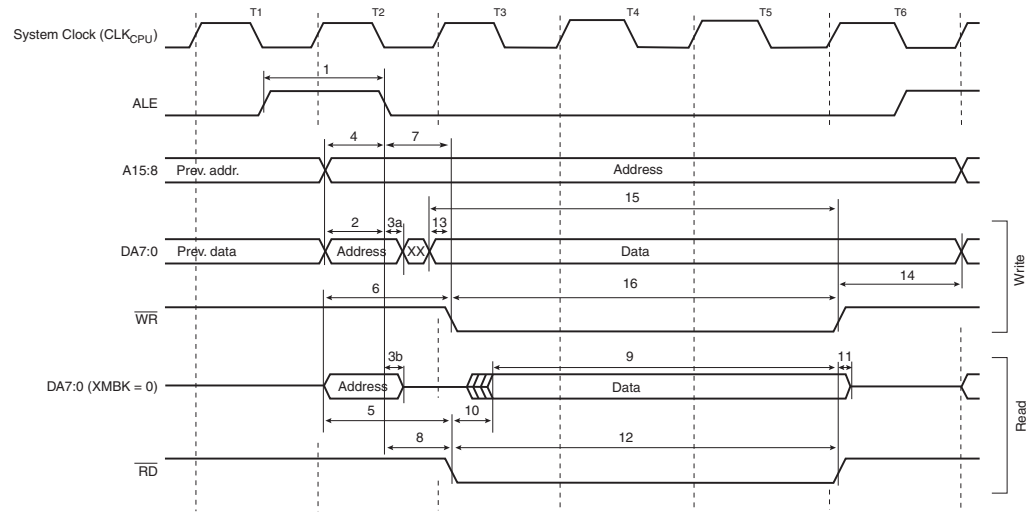
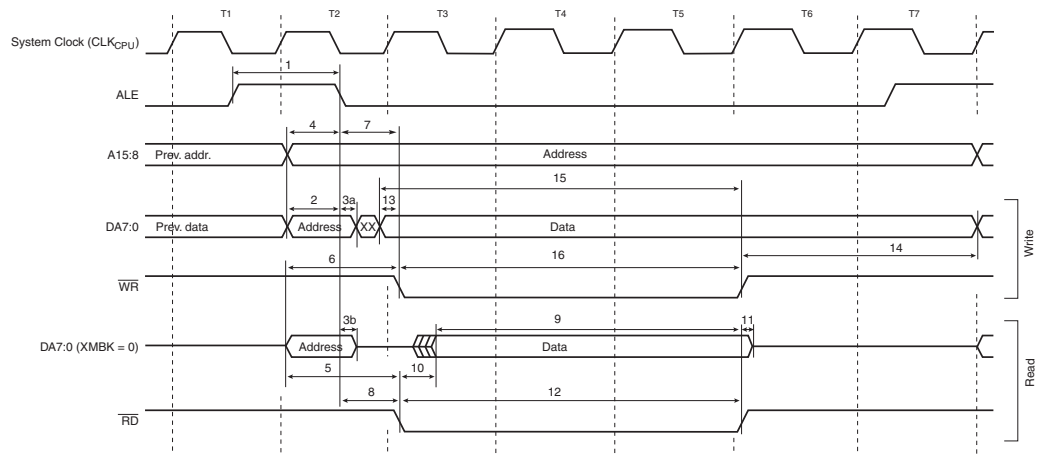

Figure 160. External Memory Timing (SRWn1 = 1, SRWn0 = 1)⁽¹⁾



Note: 1. The ALE pulse in the last period (T4-T7) is only present if the next instruction accesses the RAM (internal or external).

Typical Characteristics

The following charts show typical behavior. These figures are not tested during manufacturing. All current consumption measurements are performed with all I/O pins configured as inputs and with internal pull-ups enabled. A sine wave generator with rail-to-rail output is used as clock source.

The power consumption in Power-down mode is independent of clock selection.

The current consumption is a function of several factors such as: operating voltage, operating frequency, loading of I/O pins, switching rate of I/O pins, code executed and ambient temperature. The dominating factors are operating voltage and frequency.

The current drawn from capacitive loaded pins may be estimated (for one pin) as $C_L * V_{CC} * f$ where C_L = load capacitance, V_{CC} = operating voltage and f = average switching frequency of I/O pin.

The parts are characterized at frequencies higher than test limits. Parts are not guaranteed to function properly at frequencies higher than the ordering code indicates.

The difference between current consumption in Power-down mode with Watchdog Timer enabled and Power-down mode with Watchdog Timer disabled represents the differential current drawn by the Watchdog Timer.

Active Supply Current **Figure 161.** Active Supply Current vs. Frequency (0.1 - 1.0MHz)



Figure 162. Active Supply Current vs. Frequency (1 - 20MHz)



Figure 163. Active Supply Current vs. V_{CC} (Internal RC Oscillator, 1MHz)



Figure 164. Active Supply Current vs. V_{CC} (Internal RC Oscillator, 2MHz)



Figure 165. Active Supply Current vs. V_{CC} (Internal RC Oscillator, 4MHz)



Figure 166. Active Supply Current vs. V_{CC} (Internal RC Oscillator, 8MHz)

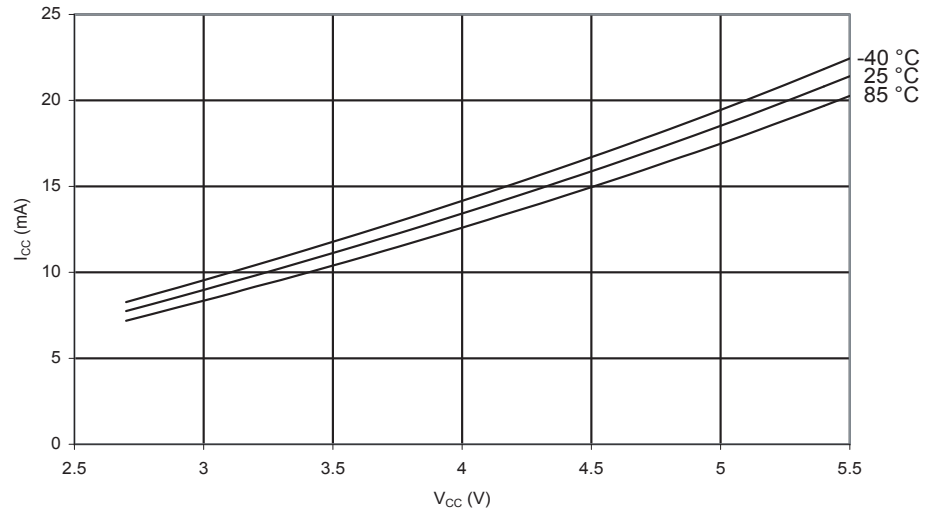
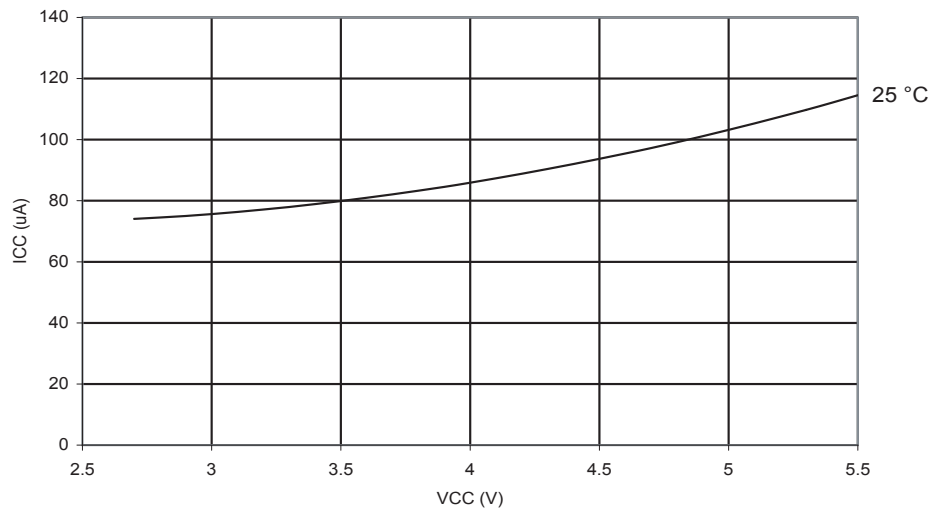

Figure 167. Active Supply Current vs. V_{CC} (32kHz External Oscillator)



Idle Supply Current

Figure 168. Idle Supply Current vs. Frequency (0.1 - 1.0MHz)



Figure 169. Idle Supply Current vs. Frequency (1 - 20MHz)



Figure 170. Idle Supply Current vs. V_{CC} (Internal RC Oscillator, 1MHz)



Figure 171. Idle Supply Current vs. V_{CC} (Internal RC Oscillator, 2MHz)

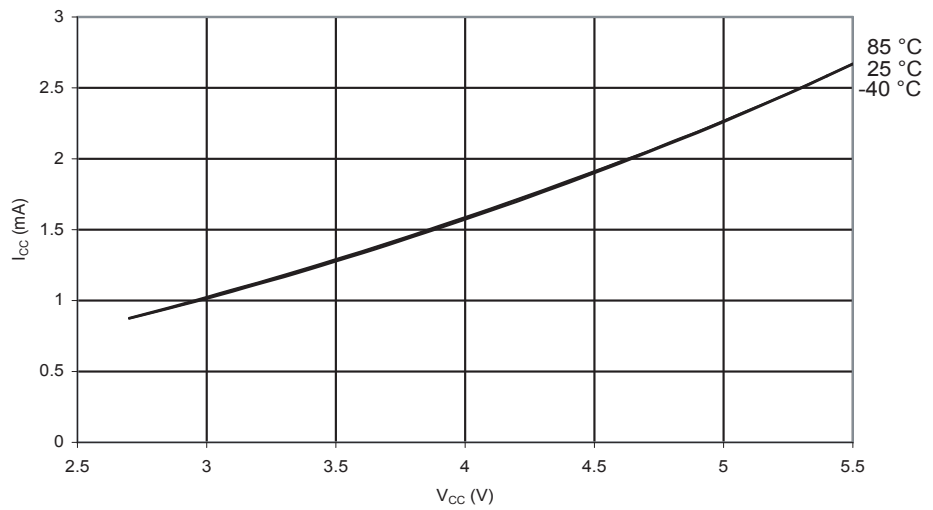

Figure 172. Idle Supply Current vs. V_{CC} (Internal RC Oscillator, 4MHz)

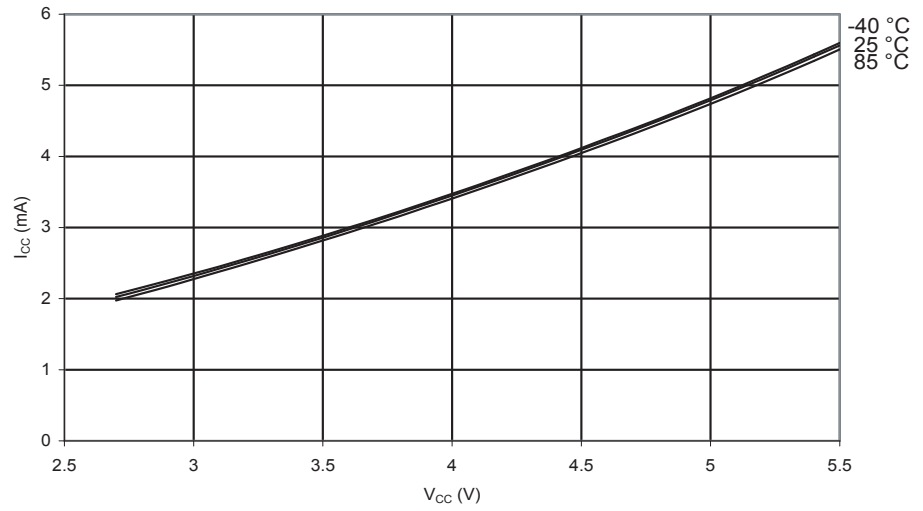

Figure 173. Idle Supply Current vs. V_{CC} (Internal RC Oscillator, 8MHz)



Figure 174. Idle Supply Current vs. V_{CC} (32kHz External Oscillator)



Power-down Supply Current

Figure 175. Power-down Supply Current vs. V_{CC} (Watchdog Timer Disabled)



Figure 176. Power-down Supply Current vs. V_{CC} (Watchdog Timer Enabled)



Power-save Supply Current

Figure 177. Power-save Supply Current vs. V_{CC} (Watchdog Timer Disabled)



Standby Supply Current

Figure 178. Standby Supply Current vs. V_{CC} ,



Figure 179. Standby Supply Current vs. V_{CC} (CKOPT programmed)

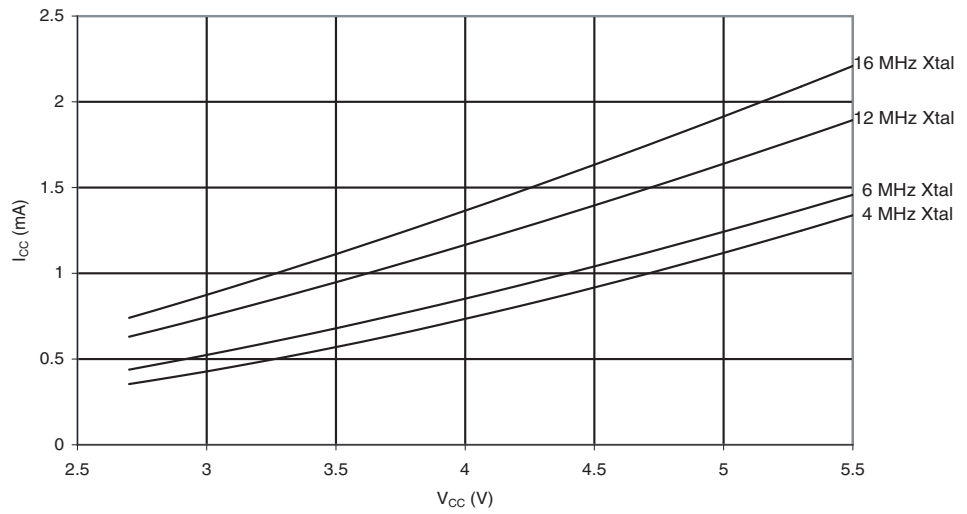

Pin Pull-up

Figure 180. I/O Pin Pull-up Resistor Current vs. Input Voltage ($V_{CC} = 5V$)



Figure 181. I/O Pin Pull-up Resistor Current vs. Input Voltage ($V_{CC} = 2.7V$)

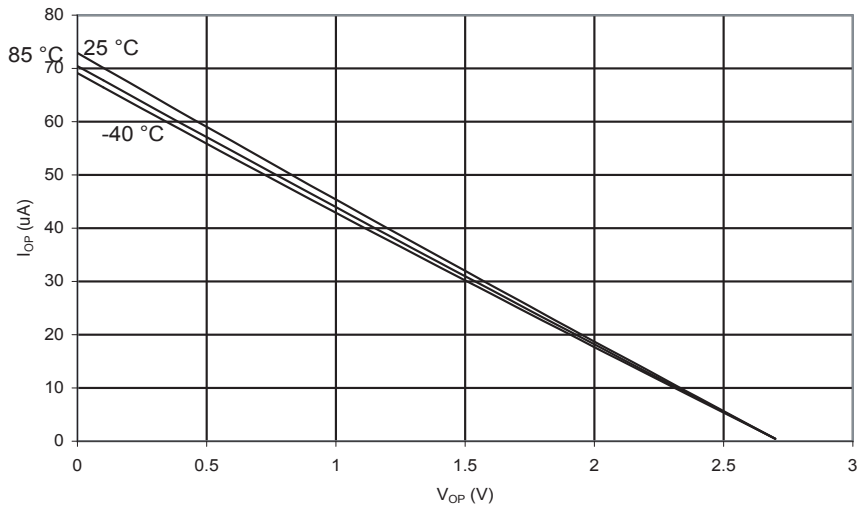

Pin Driver Strength

Figure 182. I/O Pin Source Current vs. Output Voltage ($V_{CC} = 5V$)



Figure 183. I/O Pin Source Current vs. Output Voltage ($V_{CC} = 2.7V$)



Figure 184. I/O Pin Sink Current vs. Output Voltage ($V_{CC} = 5V$)



Figure 185. I/O Pin Sink Current vs. Output Voltage, $V_{CC} = 2.7V$



Pin Thresholds and Hysteresis

Figure 186. I/O Pin Input Threshold Voltage vs. V_{CC} (V_{IH} , I/O Pin Read as '1')



Figure 187. I/O Pin Input Threshold Voltage vs. V_{CC} (V_{IL} , I/O Pin Read as '0')



Figure 188. I/O Pin Input Hysteresis vs. V_{CC}



BOD Thresholds and Analog Comparator Offset

Figure 189. BOD Threshold vs. Temperature (BODLEVEL is 4.0V)



Figure 190. BOD Threshold vs. Temperature (BODLEVEL is 2.7V)



Figure 191. Bandgap Voltage vs. Operating Voltage



Internal Oscillator Speed

Figure 192. Watchdog Oscillator Frequency vs. V_{CC}



Figure 193. Calibrated 1MHz RC Oscillator Frequency vs. Temperature



Figure 194. Calibrated 1MHz RC Oscillator Frequency vs. V_{CC}



Figure 195. 1MHz RC Oscillator Frequency vs. Oscal Value

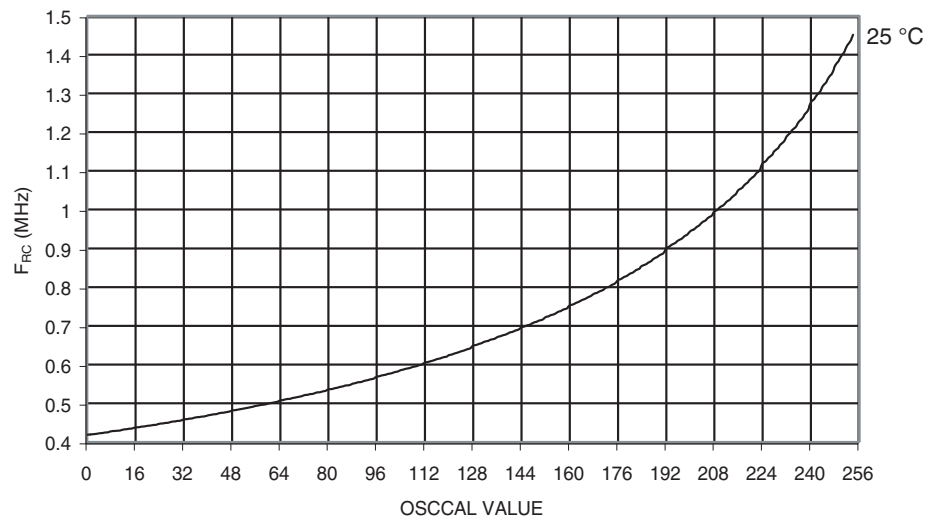

Figure 196. Calibrated 2MHz RC Oscillator Frequency vs. Temperature



Figure 197. Calibrated 2MHz RC Oscillator Frequency vs. V_{CC}



Figure 198. 2MHz RC Oscillator Frequency vs. Oscal Value



Figure 199. Calibrated 4MHz RC Oscillator Frequency vs. Temperature



Figure 200. Calibrated 4MHz RC Oscillator Frequency vs. V_{CC}



Figure 201. 4MHz RC Oscillator Frequency vs. Oscal Value



Figure 202. Calibrated 8MHz RC Oscillator Frequency vs. Temperature

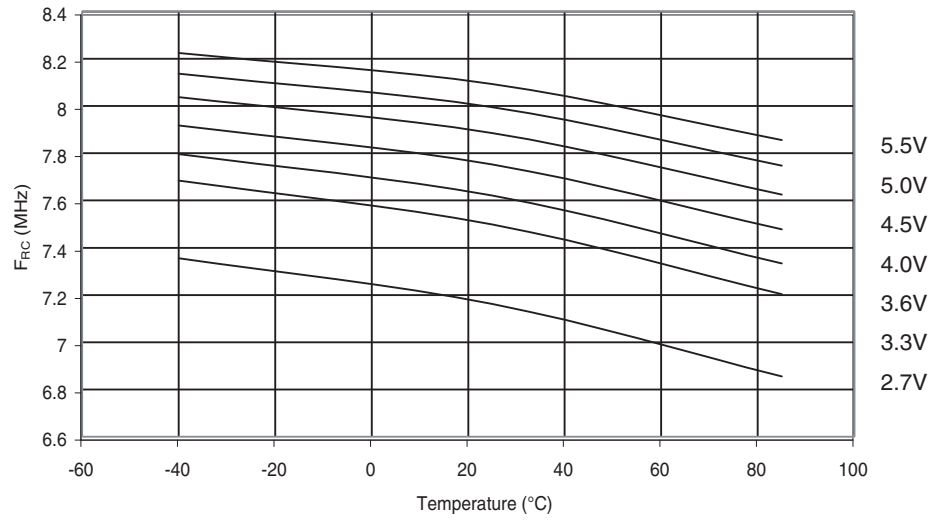

Figure 203. Calibrated 8MHz RC Oscillator Frequency vs. V_{CC}



Figure 204. 8MHz RC Oscillator Frequency vs. Oscal Value



Current Consumption of Peripheral Units

Figure 205. Brownout Detector Current vs. V_{CC}

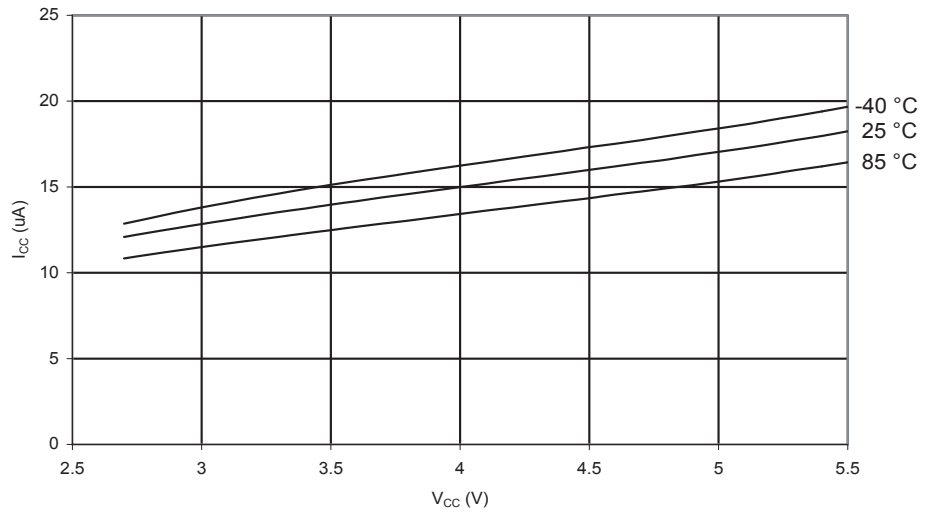

Figure 206. ADC Current vs. V_{CC} (ADC at 50kHz)



Figure 207. ADC Current vs. V_{CC} (ADC at 1MHz)



Figure 208. Analog Comparator Current vs. V_{CC}



Figure 209. Programming Current vs. V_{CC}



Current Consumption in Reset and Reset Pulse width

Figure 210. Reset Supply Current vs. V_{CC} (0.1 - 1.0MHz, Excluding Current Through The Reset Pull-up)



Figure 211. Reset Supply Current vs. V_{CC} (1 - 20MHz, Excluding Current Through The Reset Pull-up)



Figure 212. Reset Pull-up Resistor Current vs. Reset Pin Voltage ($V_{CC} = 5.0V$)



Figure 213. Reset Pull-up Resistor Current vs. Reset Pin Voltage ($V_{CC} = 2.7V$)



Figure 214. Reset Input Threshold Voltage vs. V_{CC} (VIH, Reset Pin Read as '1')



Figure 215. Reset Input Threshold Voltage vs. V_{CC} (VIL, Reset Pin Read as '0')



Figure 216. Reset Input Pin Hysteresis vs. V_{CC}



Figure 217. Reset Pulse width vs. V_{CC} (External Clock, 1MHz)



Register Summary

| Address | Name | Bit 7 | Bit 6 | Bit 5 | Bit 4 | Bit 3 | Bit 2 | Bit 1 | Bit 0 | Page |
|---------|----------|--|--------|--------|--------|--------------------------------|--------|--------|--------|------|
| (\$FF) | Reserved | – | – | – | – | – | – | – | – | |
| .. | Reserved | – | – | – | – | – | – | – | – | |
| (\$9E) | Reserved | – | – | – | – | – | – | – | – | |
| (\$9D) | UCSR1C | – | UMSEL1 | UPM11 | UPM10 | USBS1 | UCSZ11 | UCSZ10 | UCPOL1 | 190 |
| (\$9C) | UDR1 | USART1 I/O Data Register | | | | | | | | 188 |
| (\$9B) | UCSR1A | RXC1 | TXC1 | UDRE1 | FE1 | DOR1 | UPE1 | U2X1 | MPCM1 | 188 |
| (\$9A) | UCSR1B | RXCIE1 | TXCIE1 | UDRIE1 | RXEN1 | TXEN1 | UCSZ12 | RXB81 | TXB81 | 189 |
| (\$99) | UBRR1L | USART1 Baud Rate Register Low | | | | | | | | 191 |
| (\$98) | UBRR1H | – | – | – | – | USART1 Baud Rate Register High | | | | 191 |
| (\$97) | Reserved | – | – | – | – | – | – | – | – | |
| (\$96) | Reserved | – | – | – | – | – | – | – | – | |
| (\$95) | UCSR0C | – | UMSEL0 | UPM01 | UPM00 | USBS0 | UCSZ01 | UCSZ00 | UCPOL0 | 190 |
| (\$94) | Reserved | – | – | – | – | – | – | – | – | |
| (\$93) | Reserved | – | – | – | – | – | – | – | – | |
| (\$92) | Reserved | – | – | – | – | – | – | – | – | |
| (\$91) | Reserved | – | – | – | – | – | – | – | – | |
| (\$90) | UBRR0H | – | – | – | – | USART0 Baud Rate Register High | | | | 191 |
| (\$8F) | Reserved | – | – | – | – | – | – | – | – | |
| (\$8E) | Reserved | – | – | – | – | – | – | – | – | |
| (\$8D) | Reserved | – | – | – | – | – | – | – | – | |
| (\$8C) | TCCR3C | FOC3A | FOC3B | FOC3C | – | – | – | – | – | 136 |
| (\$8B) | TCCR3A | COM3A1 | COM3A0 | COM3B1 | COM3B0 | COM3C1 | COM3C0 | WGM31 | WGM30 | 132 |
| (\$8A) | TCCR3B | ICNC3 | ICES3 | – | WGM33 | WGM32 | CS32 | CS31 | CS30 | 135 |
| (\$89) | TCNT3H | Timer/Counter3 – Counter Register High Byte | | | | | | | | 137 |
| (\$88) | TCNT3L | Timer/Counter3 – Counter Register Low Byte | | | | | | | | 137 |
| (\$87) | OCR3AH | Timer/Counter3 – Output Compare Register A High Byte | | | | | | | | 137 |
| (\$86) | OCR3AL | Timer/Counter3 – Output Compare Register A Low Byte | | | | | | | | 137 |
| (\$85) | OCR3BH | Timer/Counter3 – Output Compare Register B High Byte | | | | | | | | 138 |
| (\$84) | OCR3BL | Timer/Counter3 – Output Compare Register B Low Byte | | | | | | | | 138 |
| (\$83) | OCR3CH | Timer/Counter3 – Output Compare Register C High Byte | | | | | | | | 138 |
| (\$82) | OCR3CL | Timer/Counter3 – Output Compare Register C Low Byte | | | | | | | | 138 |
| (\$81) | ICR3H | Timer/Counter3 – Input Capture Register High Byte | | | | | | | | 138 |
| (\$80) | ICR3L | Timer/Counter3 – Input Capture Register Low Byte | | | | | | | | 138 |
| (\$7F) | Reserved | – | – | – | – | – | – | – | – | |
| (\$7E) | Reserved | – | – | – | – | – | – | – | – | |
| (\$7D) | ETIMSK | – | – | TICIE3 | OCIE3A | OCIE3B | TOIE3 | OCIE3C | OCIE1C | 139 |
| (\$7C) | ETIFR | – | – | ICF3 | OCF3A | OCF3B | TOV3 | OCF3C | OCF1C | 140 |
| (\$7B) | Reserved | – | – | – | – | – | – | – | – | |
| (\$7A) | TCCR1C | FOC1A | FOC1B | FOC1C | – | – | – | – | – | 136 |
| (\$79) | OCR1CH | Timer/Counter1 – Output Compare Register C High Byte | | | | | | | | 137 |
| (\$78) | OCR1CL | Timer/Counter1 – Output Compare Register C Low Byte | | | | | | | | 137 |
| (\$77) | Reserved | – | – | – | – | – | – | – | – | |
| (\$76) | Reserved | – | – | – | – | – | – | – | – | |
| (\$75) | Reserved | – | – | – | – | – | – | – | – | |
| (\$74) | TWCR | TWINT | TWEA | TWSTA | TWSTO | TWWC | TWEN | – | TWIE | 205 |
| (\$73) | TWDR | Two-wire Serial Interface Data Register | | | | | | | | 207 |
| (\$72) | TWAR | TWA6 | TWA5 | TWA4 | TWA3 | TWA2 | TWA1 | TWA0 | TWGCE | 207 |
| (\$71) | TWSR | TWS7 | TWS6 | TWS5 | TWS4 | TWS3 | – | TWSP1 | TWSP0 | 206 |
| (\$70) | TWBR | Two-wire Serial Interface Bit Rate Register | | | | | | | | 205 |
| (\$6F) | OSCCAL | Oscillator Calibration Register | | | | | | | | 41 |
| (\$6E) | Reserved | – | – | – | – | – | – | – | – | |
| (\$6D) | XMCRA | – | SRL2 | SRL1 | SRL0 | SRW01 | SRW00 | SRW11 | – | 30 |
| (\$6C) | XMCRB | XMBK | – | – | – | – | XMM2 | XMM1 | XMM0 | 32 |
| (\$6B) | Reserved | – | – | – | – | – | – | – | – | |
| (\$6A) | EICRA | ISC31 | ISC30 | ISC21 | ISC20 | ISC11 | ISC10 | ISC01 | ISC00 | 89 |
| (\$69) | Reserved | – | – | – | – | – | – | – | – | |
| (\$68) | SPMCSR | SPMIE | RWWSB | – | RWWSRE | BLBSET | PGWRT | PGERS | SPMEN | 277 |
| (\$67) | Reserved | – | – | – | – | – | – | – | – | |
| (\$66) | Reserved | – | – | – | – | – | – | – | – | |
| (\$65) | PORTG | – | – | – | PORTG4 | PORTG3 | PORTG2 | PORTG1 | PORTG0 | 88 |
| (\$64) | DDRG | – | – | – | DDG4 | DDG3 | DDG2 | DDG1 | DDG0 | 88 |
| (\$63) | PING | – | – | – | PING4 | PING3 | PING2 | PING1 | PING0 | 88 |
| (\$62) | PORTF | PORTF7 | PORTF6 | PORTF5 | PORTF4 | PORTF3 | PORTF2 | PORTF1 | PORTF0 | 87 |

Register Summary (Continued)

| Address | Name | Bit 7 | Bit 6 | Bit 5 | Bit 4 | Bit 3 | Bit 2 | Bit 1 | Bit 0 | Page |
|-------------|----------|--|--------|--------|--------|------------------------------|--------|--------|--------|-------------------|
| (\$61) | DDRF | DDF7 | DDF6 | DDF5 | DDF4 | DDF3 | DDF2 | DDF1 | DDF0 | 88 |
| (\$60) | Reserved | – | – | – | – | – | – | – | – | |
| \$3F (\$5F) | SREG | I | T | H | S | V | N | Z | C | 10 |
| \$3E (\$5E) | SPH | SP15 | SP14 | SP13 | SP12 | SP11 | SP10 | SP9 | SP8 | 13 |
| \$3D (\$5D) | SPL | SP7 | SP6 | SP5 | SP4 | SP3 | SP2 | SP1 | SP0 | 13 |
| \$3C (\$5C) | XDIV | XDIVEN | XDIV6 | XDIV5 | XDIV4 | XDIV3 | XDIV2 | XDIV1 | XDIV0 | 36 |
| \$3B (\$5B) | RAMPZ | – | – | – | – | – | – | – | RAMPZ0 | 13 |
| \$3A (\$5A) | EICRB | ISC71 | ISC70 | ISC61 | ISC60 | ISC51 | ISC50 | ISC41 | ISC40 | 90 |
| \$39 (\$59) | EIMSK | INT7 | INT6 | INT5 | INT4 | INT3 | INT2 | INT1 | INT0 | 91 |
| \$38 (\$58) | EIFR | INTF7 | INTF6 | INTF5 | INTF4 | INTF3 | INTF | INTF1 | INTF0 | 91 |
| \$37 (\$57) | TIMSK | OCIE2 | TOIE2 | TICIE1 | OCIE1A | OCIE1B | TOIE1 | OCIE0 | TOIE0 | 108, 138, 158 |
| \$36 (\$56) | TIFR | OCF2 | TOV2 | ICF1 | OCF1A | OCF1B | TOV1 | OCF0 | TOV0 | 108, 140, 159 |
| \$35 (\$55) | MCUCR | SRE | SRW10 | SE | SM1 | SM0 | SM2 | IVSEL | IVCE | 30, 44, 63 |
| \$34 (\$54) | MCUCSR | JTD | – | – | JTRF | WDRF | BORF | EXTRF | PORF | 53, 254 |
| \$33 (\$53) | TCCR0 | FOC0 | WGM00 | COM01 | COM00 | WGM01 | CS02 | CS01 | CS00 | 103 |
| \$32 (\$52) | TCNT0 | Timer/Counter0 (8 Bit) | | | | | | | | 105 |
| \$31 (\$51) | OCR0 | Timer/Counter0 Output Compare Register | | | | | | | | 105 |
| \$30 (\$50) | ASSR | – | – | – | – | AS0 | TCN0UB | OCR0UB | TCR0UB | 106 |
| \$2F (\$4F) | TCCR1A | COM1A1 | COM1A0 | COM1B1 | COM1B0 | COM1C1 | COM1C0 | WGM11 | WGM10 | 132 |
| \$2E (\$4E) | TCCR1B | ICNC1 | ICES1 | – | WGM13 | WGM12 | CS12 | CS11 | CS10 | 135 |
| \$2D (\$4D) | TCNT1H | Timer/Counter1 – Counter Register High Byte | | | | | | | | 137 |
| \$2C (\$4C) | TCNT1L | Timer/Counter1 – Counter Register Low Byte | | | | | | | | 137 |
| \$2B (\$4B) | OCR1AH | Timer/Counter1 – Output Compare Register A High Byte | | | | | | | | 137 |
| \$2A (\$4A) | OCR1AL | Timer/Counter1 – Output Compare Register A Low Byte | | | | | | | | 137 |
| \$29 (\$49) | OCR1BH | Timer/Counter1 – Output Compare Register B High Byte | | | | | | | | 137 |
| \$28 (\$48) | OCR1BL | Timer/Counter1 – Output Compare Register B Low Byte | | | | | | | | 137 |
| \$27 (\$47) | ICR1H | Timer/Counter1 – Input Capture Register High Byte | | | | | | | | 138 |
| \$26 (\$46) | ICR1L | Timer/Counter1 – Input Capture Register Low Byte | | | | | | | | 138 |
| \$25 (\$45) | TCCR2 | FOC2 | WGM20 | COM21 | COM20 | WGM21 | CS22 | CS21 | CS20 | 156 |
| \$24 (\$44) | TCNT2 | Timer/Counter2 (8 Bit) | | | | | | | | 158 |
| \$23 (\$43) | OCR2 | Timer/Counter2 Output Compare Register | | | | | | | | 158 |
| \$22 (\$42) | OCDR | IDRD/OCDR7 | OCDR6 | OCDR5 | OCDR4 | OCDR3 | OCDR2 | OCDR1 | OCDR0 | 251 |
| \$21 (\$41) | WDTCR | – | – | – | WDCE | WDE | WDP2 | WDP1 | WDP0 | 55 |
| \$20 (\$40) | SFIOR | TSM | – | – | – | ACME | PUD | PSR0 | PSR321 | 72, 109, 144, 227 |
| \$1F (\$3F) | EEARH | – | – | – | – | EEPROM Address Register High | | | | 20 |
| \$1E (\$3E) | EEARL | EEPROM Address Register Low Byte | | | | | | | | 20 |
| \$1D (\$3D) | EEDR | EEPROM Data Register | | | | | | | | 21 |
| \$1C (\$3C) | EEDR | – | – | – | – | EERIE | EEMWE | EEWE | EERE | 21 |
| \$1B (\$3B) | PORTA | PORTA7 | PORTA6 | PORTA5 | PORTA4 | PORTA3 | PORTA2 | PORTA1 | PORTA0 | 86 |
| \$1A (\$3A) | DDRA | DDA7 | DDA6 | DDA5 | DDA4 | DDA3 | DDA2 | DDA1 | DDA0 | 86 |
| \$19 (\$39) | PINA | PINA7 | PINA6 | PINA5 | PINA4 | PINA3 | PINA2 | PINA1 | PINA0 | 86 |
| \$18 (\$38) | PORTB | PORTB7 | PORTB6 | PORTB5 | PORTB4 | PORTB3 | PORTB2 | PORTB1 | PORTB0 | 86 |
| \$17 (\$37) | DDRB | DDB7 | DDB6 | DDB5 | DDB4 | DDB3 | DDB2 | DDB1 | DDB0 | 86 |
| \$16 (\$36) | PINB | PINB7 | PINB6 | PINB5 | PINB4 | PINB3 | PINB2 | PINB1 | PINB0 | 86 |
| \$15 (\$35) | PORTC | PORTC7 | PORTC6 | PORTC5 | PORTC4 | PORTC3 | PORTC2 | PORTC1 | PORTC0 | 86 |
| \$14 (\$34) | DDRC | DDC7 | DDC6 | DDC5 | DDC4 | DDC3 | DDC2 | DDC1 | DDC0 | 86 |
| \$13 (\$33) | PINC | PINC7 | PINC6 | PINC5 | PINC4 | PINC3 | PINC2 | PINC1 | PINC0 | 87 |
| \$12 (\$32) | PORTD | PORTD7 | PORTD6 | PORTD5 | PORTD4 | PORTD3 | PORTD2 | PORTD1 | PORTD0 | 87 |
| \$11 (\$31) | DDRD | DDD7 | DDD6 | DDD5 | DDD4 | DDD3 | DDD2 | DDD1 | DDD0 | 87 |
| \$10 (\$30) | PIND | PIND7 | PIND6 | PIND5 | PIND4 | PIND3 | PIND2 | PIND1 | PIND0 | 87 |
| \$0F (\$2F) | SPDR | SPI Data Register | | | | | | | | 168 |
| \$0E (\$2E) | SPSR | SPIF | WCOL | – | – | – | – | – | SPI2X | 168 |
| \$0D (\$2D) | SPCR | SPIE | SPE | DORD | MSTR | CPOL | CPHA | SPR1 | SPR0 | 166 |
| \$0C (\$2C) | UDR0 | USART0 I/O Data Register | | | | | | | | 188 |
| \$0B (\$2B) | UCSR0A | RXC0 | TXC0 | UDRE0 | FE0 | DOR0 | UPE0 | U2X0 | MPCM0 | 188 |
| \$0A (\$2A) | UCSR0B | RXCIE0 | TXCIE0 | UDRIE0 | RXEN0 | TXEN0 | UCSZ02 | RXB80 | TXB80 | 189 |
| \$09 (\$29) | UBRR0L | USART0 Baud Rate Register Low | | | | | | | | 191 |
| \$08 (\$28) | ACSR | ACD | ACBG | ACO | ACI | ACIE | ACIC | ACIS1 | ACIS0 | 227 |
| \$07 (\$27) | ADMUX | REFS1 | REFS0 | ADLAR | MUX4 | MUX3 | MUX2 | MUX1 | MUX0 | 242 |
| \$06 (\$26) | ADCSRA | ADEN | ADSC | ADFR | ADIF | ADIE | ADPS2 | ADPS1 | ADPS0 | 244 |
| \$05 (\$25) | ADCH | ADC Data Register High Byte | | | | | | | | 245 |
| \$04 (\$24) | ADCL | ADC Data Register Low Byte | | | | | | | | 245 |
| \$03 (\$23) | PORTE | PORTE7 | PORTE6 | PORTE5 | PORTE4 | PORTE3 | PORTE2 | PORTE1 | PORTE0 | 87 |
| \$02 (\$22) | DDRE | DDE7 | DDE6 | DDE5 | DDE4 | DDE3 | DDE2 | DDE1 | DDE0 | 87 |

Register Summary (Continued)

| Address | Name | Bit 7 | Bit 6 | Bit 5 | Bit 4 | Bit 3 | Bit 2 | Bit 1 | Bit 0 | Page |
|-------------|------|-------|-------|-------|-------|-------|-------|-------|-------|------|
| \$01 (\$21) | PINE | PINE7 | PINE6 | PINE5 | PINE4 | PINE3 | PINE2 | PINE1 | PINE0 | 87 |
| \$00 (\$20) | PINF | PINF7 | PINF6 | PINF5 | PINF4 | PINF3 | PINF2 | PINF1 | PINF0 | 88 |

- Notes:
1. For compatibility with future devices, reserved bits should be written to zero if accessed. Reserved I/O memory addresses should never be written.
 2. Some of the status flags are cleared by writing a logical one to them. Note that the CBI and SBI instructions will operate on all bits in the I/O register, writing a one back into any flag read as set, thus clearing the flag. The CBI and SBI instructions work with registers \$00 to \$1F only.

Instruction Set Summary

| Mnemonics | Operands | Description | Operation | Flags | #Clocks |
|--|----------|--|---|---------------|-----------|
| ARITHMETIC AND LOGIC INSTRUCTIONS | | | | | |
| ADD | Rd, Rr | Add two Registers | $Rd \leftarrow Rd + Rr$ | Z,C,N,V,H | 1 |
| ADC | Rd, Rr | Add with Carry two Registers | $Rd \leftarrow Rd + Rr + C$ | Z,C,N,V,H | 1 |
| ADIW | RdI,K | Add Immediate to Word | $Rdh:Rdl \leftarrow Rdh:Rdl + K$ | Z,C,N,V,S | 2 |
| SUB | Rd, Rr | Subtract two Registers | $Rd \leftarrow Rd - Rr$ | Z,C,N,V,H | 1 |
| SUBI | Rd, K | Subtract Constant from Register | $Rd \leftarrow Rd - K$ | Z,C,N,V,H | 1 |
| SBC | Rd, Rr | Subtract with Carry two Registers | $Rd \leftarrow Rd - Rr - C$ | Z,C,N,V,H | 1 |
| SBCI | Rd, K | Subtract with Carry Constant from Reg. | $Rd \leftarrow Rd - K - C$ | Z,C,N,V,H | 1 |
| SBIW | RdI,K | Subtract Immediate from Word | $Rdh:Rdl \leftarrow Rdh:Rdl - K$ | Z,C,N,V,S | 2 |
| AND | Rd, Rr | Logical AND Registers | $Rd \leftarrow Rd \bullet Rr$ | Z,N,V | 1 |
| ANDI | Rd, K | Logical AND Register and Constant | $Rd \leftarrow Rd \bullet K$ | Z,N,V | 1 |
| OR | Rd, Rr | Logical OR Registers | $Rd \leftarrow Rd \vee Rr$ | Z,N,V | 1 |
| ORI | Rd, K | Logical OR Register and Constant | $Rd \leftarrow Rd \vee K$ | Z,N,V | 1 |
| EOR | Rd, Rr | Exclusive OR Registers | $Rd \leftarrow Rd \oplus Rr$ | Z,N,V | 1 |
| COM | Rd | One's Complement | $Rd \leftarrow \text{\$FF} - Rd$ | Z,C,N,V | 1 |
| NEG | Rd | Two's Complement | $Rd \leftarrow \text{\$00} - Rd$ | Z,C,N,V,H | 1 |
| SBR | Rd,K | Set Bit(s) in Register | $Rd \leftarrow Rd \vee K$ | Z,N,V | 1 |
| CBR | Rd,K | Clear Bit(s) in Register | $Rd \leftarrow Rd \bullet (\text{\$FF} - K)$ | Z,N,V | 1 |
| INC | Rd | Increment | $Rd \leftarrow Rd + 1$ | Z,N,V | 1 |
| DEC | Rd | Decrement | $Rd \leftarrow Rd - 1$ | Z,N,V | 1 |
| TST | Rd | Test for Zero or Minus | $Rd \leftarrow Rd \bullet Rd$ | Z,N,V | 1 |
| CLR | Rd | Clear Register | $Rd \leftarrow Rd \oplus Rd$ | Z,N,V | 1 |
| SER | Rd | Set Register | $Rd \leftarrow \text{\$FF}$ | None | 1 |
| MUL | Rd, Rr | Multiply Unsigned | $R1:R0 \leftarrow Rd \times Rr$ | Z,C | 2 |
| MULS | Rd, Rr | Multiply Signed | $R1:R0 \leftarrow Rd \times Rr$ | Z,C | 2 |
| MULSU | Rd, Rr | Multiply Signed with Unsigned | $R1:R0 \leftarrow Rd \times Rr$ | Z,C | 2 |
| FMUL | Rd, Rr | Fractional Multiply Unsigned | $R1:R0 \leftarrow (Rd \times Rr) \lll 1$ | Z,C | 2 |
| FMULS | Rd, Rr | Fractional Multiply Signed | $R1:R0 \leftarrow (Rd \times Rr) \lll 1$ | Z,C | 2 |
| FMULSU | Rd, Rr | Fractional Multiply Signed with Unsigned | $R1:R0 \leftarrow (Rd \times Rr) \lll 1$ | Z,C | 2 |
| BRANCH INSTRUCTIONS | | | | | |
| RJMP | k | Relative Jump | $PC \leftarrow PC + k + 1$ | None | 2 |
| IJMP | | Indirect Jump to (Z) | $PC \leftarrow Z$ | None | 2 |
| JMP | k | Direct Jump | $PC \leftarrow k$ | None | 3 |
| RCALL | k | Relative Subroutine Call | $PC \leftarrow PC + k + 1$ | None | 3 |
| ICALL | | Indirect Call to (Z) | $PC \leftarrow Z$ | None | 3 |
| CALL | k | Direct Subroutine Call | $PC \leftarrow k$ | None | 4 |
| RET | | Subroutine Return | $PC \leftarrow \text{STACK}$ | None | 4 |
| RETI | | Interrupt Return | $PC \leftarrow \text{STACK}$ | I | 4 |
| CPSE | Rd,Rr | Compare, Skip if Equal | if $(Rd = Rr)$ $PC \leftarrow PC + 2$ or 3 | None | 1 / 2 / 3 |
| CP | Rd,Rr | Compare | $Rd - Rr$ | Z, N, V, C, H | 1 |
| CPC | Rd,Rr | Compare with Carry | $Rd - Rr - C$ | Z, N, V, C, H | 1 |
| CPI | Rd,K | Compare Register with Immediate | $Rd - K$ | Z, N, V, C, H | 1 |
| SBRC | Rr, b | Skip if Bit in Register Cleared | if $(Rr(b)=0)$ $PC \leftarrow PC + 2$ or 3 | None | 1 / 2 / 3 |
| SBRS | Rr, b | Skip if Bit in Register is Set | if $(Rr(b)=1)$ $PC \leftarrow PC + 2$ or 3 | None | 1 / 2 / 3 |
| SBIC | P, b | Skip if Bit in I/O Register Cleared | if $(P(b)=0)$ $PC \leftarrow PC + 2$ or 3 | None | 1 / 2 / 3 |
| SBIS | P, b | Skip if Bit in I/O Register is Set | if $(P(b)=1)$ $PC \leftarrow PC + 2$ or 3 | None | 1 / 2 / 3 |
| BRBS | s, k | Branch if Status Flag Set | if $(SREG(s) = 1)$ then $PC \leftarrow PC + k + 1$ | None | 1 / 2 |
| BRBC | s, k | Branch if Status Flag Cleared | if $(SREG(s) = 0)$ then $PC \leftarrow PC + k + 1$ | None | 1 / 2 |
| BREQ | k | Branch if Equal | if $(Z = 1)$ then $PC \leftarrow PC + k + 1$ | None | 1 / 2 |
| BRNE | k | Branch if Not Equal | if $(Z = 0)$ then $PC \leftarrow PC + k + 1$ | None | 1 / 2 |
| BRCS | k | Branch if Carry Set | if $(C = 1)$ then $PC \leftarrow PC + k + 1$ | None | 1 / 2 |
| BRCC | k | Branch if Carry Cleared | if $(C = 0)$ then $PC \leftarrow PC + k + 1$ | None | 1 / 2 |
| BRSH | k | Branch if Same or Higher | if $(C = 0)$ then $PC \leftarrow PC + k + 1$ | None | 1 / 2 |
| BRLO | k | Branch if Lower | if $(C = 1)$ then $PC \leftarrow PC + k + 1$ | None | 1 / 2 |
| BRMI | k | Branch if Minus | if $(N = 1)$ then $PC \leftarrow PC + k + 1$ | None | 1 / 2 |
| BRPL | k | Branch if Plus | if $(N = 0)$ then $PC \leftarrow PC + k + 1$ | None | 1 / 2 |
| BRGE | k | Branch if Greater or Equal, Signed | if $(N \oplus V = 0)$ then $PC \leftarrow PC + k + 1$ | None | 1 / 2 |
| BRLT | k | Branch if Less Than Zero, Signed | if $(N \oplus V = 1)$ then $PC \leftarrow PC + k + 1$ | None | 1 / 2 |
| BRHS | k | Branch if Half Carry Flag Set | if $(H = 1)$ then $PC \leftarrow PC + k + 1$ | None | 1 / 2 |
| BRHC | k | Branch if Half Carry Flag Cleared | if $(H = 0)$ then $PC \leftarrow PC + k + 1$ | None | 1 / 2 |
| BRTS | k | Branch if T Flag Set | if $(T = 1)$ then $PC \leftarrow PC + k + 1$ | None | 1 / 2 |
| BRTC | k | Branch if T Flag Cleared | if $(T = 0)$ then $PC \leftarrow PC + k + 1$ | None | 1 / 2 |
| BRVS | k | Branch if Overflow Flag is Set | if $(V = 1)$ then $PC \leftarrow PC + k + 1$ | None | 1 / 2 |
| BRVC | k | Branch if Overflow Flag is Cleared | if $(V = 0)$ then $PC \leftarrow PC + k + 1$ | None | 1 / 2 |

Instruction Set Summary (Continued)

| Mnemonics | Operands | Description | Operation | Flags | #Clocks |
|--------------------------------------|----------|---|--|------------|---------|
| BRIE | k | Branch if Interrupt Enabled | if (I = 1) then PC ← PC + k + 1 | None | 1 / 2 |
| BRID | k | Branch if Interrupt Disabled | if (I = 0) then PC ← PC + k + 1 | None | 1 / 2 |
| DATA TRANSFER INSTRUCTIONS | | | | | |
| MOV | Rd, Rr | Move Between Registers | Rd ← Rr | None | 1 |
| MOVW | Rd, Rr | Copy Register Word | Rd+1:Rd ← Rr+1:Rr | None | 1 |
| LDI | Rd, K | Load Immediate | Rd ← K | None | 1 |
| LD | Rd, X | Load Indirect | Rd ← (X) | None | 2 |
| LD | Rd, X+ | Load Indirect and Post-Inc. | Rd ← (X), X ← X + 1 | None | 2 |
| LD | Rd, -X | Load Indirect and Pre-Dec. | X ← X - 1, Rd ← (X) | None | 2 |
| LD | Rd, Y | Load Indirect | Rd ← (Y) | None | 2 |
| LD | Rd, Y+ | Load Indirect and Post-Inc. | Rd ← (Y), Y ← Y + 1 | None | 2 |
| LD | Rd, -Y | Load Indirect and Pre-Dec. | Y ← Y - 1, Rd ← (Y) | None | 2 |
| LDD | Rd, Y+q | Load Indirect with Displacement | Rd ← (Y + q) | None | 2 |
| LD | Rd, Z | Load Indirect | Rd ← (Z) | None | 2 |
| LD | Rd, Z+ | Load Indirect and Post-Inc. | Rd ← (Z), Z ← Z+1 | None | 2 |
| LD | Rd, -Z | Load Indirect and Pre-Dec. | Z ← Z - 1, Rd ← (Z) | None | 2 |
| LDD | Rd, Z+q | Load Indirect with Displacement | Rd ← (Z + q) | None | 2 |
| LDS | Rd, k | Load Direct from SRAM | Rd ← (k) | None | 2 |
| ST | X, Rr | Store Indirect | (X) ← Rr | None | 2 |
| ST | X+, Rr | Store Indirect and Post-Inc. | (X) ← Rr, X ← X + 1 | None | 2 |
| ST | -X, Rr | Store Indirect and Pre-Dec. | X ← X - 1, (X) ← Rr | None | 2 |
| ST | Y, Rr | Store Indirect | (Y) ← Rr | None | 2 |
| ST | Y+, Rr | Store Indirect and Post-Inc. | (Y) ← Rr, Y ← Y + 1 | None | 2 |
| ST | -Y, Rr | Store Indirect and Pre-Dec. | Y ← Y - 1, (Y) ← Rr | None | 2 |
| STD | Y+q, Rr | Store Indirect with Displacement | (Y + q) ← Rr | None | 2 |
| ST | Z, Rr | Store Indirect | (Z) ← Rr | None | 2 |
| ST | Z+, Rr | Store Indirect and Post-Inc. | (Z) ← Rr, Z ← Z + 1 | None | 2 |
| ST | -Z, Rr | Store Indirect and Pre-Dec. | Z ← Z - 1, (Z) ← Rr | None | 2 |
| STD | Z+q, Rr | Store Indirect with Displacement | (Z + q) ← Rr | None | 2 |
| STS | k, Rr | Store Direct to SRAM | (k) ← Rr | None | 2 |
| LPM | | Load Program Memory | R0 ← (Z) | None | 3 |
| LPM | Rd, Z | Load Program Memory | Rd ← (Z) | None | 3 |
| LPM | Rd, Z+ | Load Program Memory and Post-Inc | Rd ← (Z), Z ← Z+1 | None | 3 |
| ELPM | | Extended Load Program Memory | R0 ← (RAMPZ:Z) | None | 3 |
| ELPM | Rd, Z | Extended Load Program Memory | Rd ← (RAMPZ:Z) | None | 3 |
| ELPM | Rd, Z+ | Extended Load Program Memory and Post-Inc | Rd ← (RAMPZ:Z), RAMPZ:Z ← RAMPZ:Z+1 | None | 3 |
| SPM | | Store Program Memory | (Z) ← R1:R0 | None | - |
| IN | Rd, P | In Port | Rd ← P | None | 1 |
| OUT | P, Rr | Out Port | P ← Rr | None | 1 |
| PUSH | Rr | Push Register on Stack | STACK ← Rr | None | 2 |
| POP | Rd | Pop Register from Stack | Rd ← STACK | None | 2 |
| BIT AND BIT-TEST INSTRUCTIONS | | | | | |
| SBI | P, b | Set Bit in I/O Register | I/O(P, b) ← 1 | None | 2 |
| CBI | P, b | Clear Bit in I/O Register | I/O(P, b) ← 0 | None | 2 |
| LSL | Rd | Logical Shift Left | Rd(n+1) ← Rd(n), Rd(0) ← 0 | Z, C, N, V | 1 |
| LSR | Rd | Logical Shift Right | Rd(n) ← Rd(n+1), Rd(7) ← 0 | Z, C, N, V | 1 |
| ROL | Rd | Rotate Left Through Carry | Rd(0) ← C, Rd(n+1) ← Rd(n), C ← Rd(7) | Z, C, N, V | 1 |
| ROR | Rd | Rotate Right Through Carry | Rd(7) ← C, Rd(n) ← Rd(n+1), C ← Rd(0) | Z, C, N, V | 1 |
| ASR | Rd | Arithmetic Shift Right | Rd(n) ← Rd(n+1), n=0..6 | Z, C, N, V | 1 |
| SWAP | Rd | Swap Nibbles | Rd(3..0) ← Rd(7..4), Rd(7..4) ← Rd(3..0) | None | 1 |
| BSET | s | Flag Set | SREG(s) ← 1 | SREG(s) | 1 |
| BCLR | s | Flag Clear | SREG(s) ← 0 | SREG(s) | 1 |
| BST | Rr, b | Bit Store from Register to T | T ← Rr(b) | T | 1 |
| BLD | Rd, b | Bit load from T to Register | Rd(b) ← T | None | 1 |
| SEC | | Set Carry | C ← 1 | C | 1 |
| CLC | | Clear Carry | C ← 0 | C | 1 |
| SEN | | Set Negative Flag | N ← 1 | N | 1 |
| CLN | | Clear Negative Flag | N ← 0 | N | 1 |
| SEZ | | Set Zero Flag | Z ← 1 | Z | 1 |
| CLZ | | Clear Zero Flag | Z ← 0 | Z | 1 |
| SEI | | Global Interrupt Enable | I ← 1 | I | 1 |
| CLI | | Global Interrupt Disable | I ← 0 | I | 1 |
| SES | | Set Signed Test Flag | S ← 1 | S | 1 |
| CLS | | Clear Signed Test Flag | S ← 0 | S | 1 |

Instruction Set Summary (Continued)

| Mnemonics | Operands | Description | Operation | Flags | #Clocks |
|---------------------------------|----------|--------------------------------|--|-------|---------|
| SEV | | Set Twos Complement Overflow. | $V \leftarrow 1$ | V | 1 |
| CLV | | Clear Twos Complement Overflow | $V \leftarrow 0$ | V | 1 |
| SET | | Set T in SREG | $T \leftarrow 1$ | T | 1 |
| CLT | | Clear T in SREG | $T \leftarrow 0$ | T | 1 |
| SEH | | Set Half Carry Flag in SREG | $H \leftarrow 1$ | H | 1 |
| CLH | | Clear Half Carry Flag in SREG | $H \leftarrow 0$ | H | 1 |
| MCU CONTROL INSTRUCTIONS | | | | | |
| NOP | | No Operation | | None | 1 |
| SLEEP | | Sleep | (see specific descr. for Sleep function) | None | 1 |
| WDR | | Watchdog Reset | (see specific descr. for WDR/timer) | None | 1 |
| BREAK | | Break | For On-chip Debug Only | None | N/A |

Ordering Information

| Speed (MHz) | Power Supply | Ordering Code ⁽¹⁾ | Package ⁽²⁾ | Operation Range |
|-------------|--------------|--------------------------------|------------------------|-------------------------------|
| 8 | 2.7 – 5.5V | ATmega128L-8AU | 64A | Industrial (-40°C to 85°C) |
| | | ATmega128L-8AUR ⁽³⁾ | 64A | |
| 16 | 4.5 – 5.5V | ATmega128L-8MU | 64M1 | |
| | | ATmega128L-8MUR ⁽³⁾ | 64M1 | |
| 8 | 3.0 – 5.5V | ATmega128-16AU | 64A | Extended (-40°C to 105°C) |
| | | ATmega128-16AUR ⁽³⁾ | 64A | |
| 16 | 4.5 – 5.5V | ATmega128-16MU | 64M1 | |
| | | ATmega128-16MUR ⁽³⁾ | 64M1 | |
| 8 | 3.0 – 5.5V | ATmega128L-8AN | 64A | Extended (-40°C to 105°C) |
| | | ATmega128L-8ANR ⁽³⁾ | 64A | |
| 16 | 4.5 – 5.5V | ATmega128L-8MN | 64M1 | |
| | | ATmega128L-8MNR ⁽³⁾ | 64M1 | |
| 8 | 3.0 – 5.5V | ATmega128-16AN | 64A | Extended (-40°C to 105°C) |
| | | ATmega128-16ANR ⁽³⁾ | 64A | |
| 16 | 4.5 – 5.5V | ATmega128-16MN | 64M1 | |
| | | ATmega128-16MNR ⁽³⁾ | 64M1 | |

- Notes:
1. Pb-free packaging complies to the European Directive for Restriction of Hazardous Substances (RoHS directive). Also Halide free and fully Green.
 2. The device can also be supplied in wafer form. Please contact your local Atmel sales office for detailed ordering information and minimum quantities.
 3. Tape and Reel

| Package Type | |
|--------------|---|
| 64A | 64-lead, 14 x 14 x 1.0mm, Thin Profile Plastic Quad Flat Package (TQFP) |
| 64M1 | 64-pad, 9 x 9 x 1.0mm, Quad Flat No-Lead/Micro Lead Frame Package (QFN/MLF) |

Packaging Information

64A

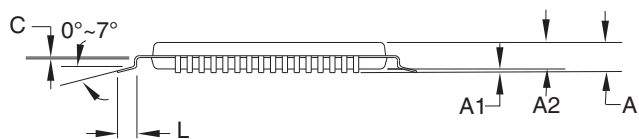
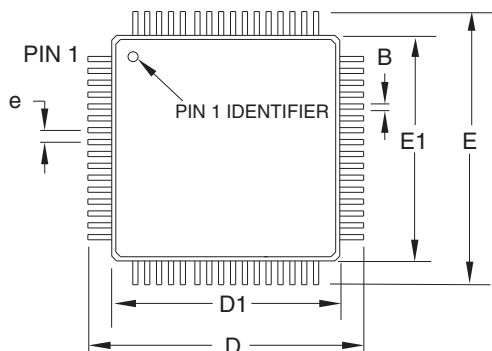

COMMON DIMENSIONS
(Unit of Measure = mm)

| SYMBOL | MIN | NOM | MAX | NOTE |
|--------|----------|-------|-------|--------|
| A | – | – | 1.20 | |
| A1 | 0.05 | – | 0.15 | |
| A2 | 0.95 | 1.00 | 1.05 | |
| D | 15.75 | 16.00 | 16.25 | |
| D1 | 13.90 | 14.00 | 14.10 | Note 2 |
| E | 15.75 | 16.00 | 16.25 | |
| E1 | 13.90 | 14.00 | 14.10 | Note 2 |
| B | 0.30 | – | 0.45 | |
| C | 0.09 | – | 0.20 | |
| L | 0.45 | – | 0.75 | |
| e | 0.80 TYP | | | |

Notes:

1. This package conforms to JEDEC reference MS-026, Variation AEB.
2. Dimensions D1 and E1 do not include mold protrusion. Allowable protrusion is 0.25 mm per side. Dimensions D1 and E1 are maximum plastic body size dimensions including mold mismatch.
3. Lead coplanarity is 0.10 mm maximum.

2010-10-20

| | | | |
|--|--|--------------------|-------------|
|  2325 Orchard Parkway San Jose, CA 95131 | TITLE | DRAWING NO. | REV. |
| | 64A , 64-lead, 14 x 14 mm Body Size, 1.0 mm Body Thickness, 0.8 mm Lead Pitch, Thin Profile Plastic Quad Flat Package (TQFP) | 64A | C |

64M1



Errata

The revision letter in this section refers to the revision of the ATmega128 device.

ATmega128 Rev. F to M

- First Analog Comparator conversion may be delayed
- Interrupts may be lost when writing the timer registers in the asynchronous timer
- Stabilizing time needed when changing XDIV Register
- Stabilizing time needed when changing OSCCAL Register
- IDCODE masks data from TDI input
- Reading EEPROM by using ST or STS to set EERE bit triggers unexpected interrupt request

1. First Analog Comparator conversion may be delayed

If the device is powered by a slow rising V_{CC} , the first Analog Comparator conversion will take longer than expected on some devices.

Problem Fix/Workaround

When the device has been powered or reset, disable then enable the Analog Comparator before the first conversion.

2. Interrupts may be lost when writing the timer registers in the asynchronous timer

The interrupt will be lost if a timer register that is synchronous timer clock is written when the asynchronous Timer/Counter register (TCNTx) is 0x00.

Problem Fix/Workaround

Always check that the asynchronous Timer/Counter register neither have the value 0xFF nor 0x00 before writing to the asynchronous Timer Control Register (TCCRx), asynchronous Timer Counter Register (TCNTx), or asynchronous Output Compare Register (OCRx).

3. Stabilizing time needed when changing XDIV Register

After increasing the source clock frequency more than 2% with settings in the XDIV register, the device may execute some of the subsequent instructions incorrectly.

Problem Fix / Workaround

The NOP instruction will always be executed correctly also right after a frequency change. Thus, the next 8 instructions after the change should be NOP instructions. To ensure this, follow this procedure:

1. Clear the I bit in the SREG Register.
2. Set the new pre-scaling factor in XDIV register.
3. Execute 8 NOP instructions
4. Set the I bit in SREG

This will ensure that all subsequent instructions will execute correctly.

Assembly Code Example:

```

CLI                ; clear global interrupt enable
OUT  XDIV, temp    ; set new prescale value
NOP                ; no operation
NOP                ; no operation
NOP                ; no operation
NOP                ; no operation
NOP                ; no operation
NOP                ; no operation
NOP                ; no operation
NOP                ; no operation
NOP                ; no operation
NOP                ; no operation

```

```
SEI ; set global interrupt enable
```

4. Stabilizing time needed when changing OSCCAL Register

After increasing the source clock frequency more than 2% with settings in the OSCCAL register, the device may execute some of the subsequent instructions incorrectly.

Problem Fix / Workaround

The behavior follows errata number 3., and the same Fix / Workaround is applicable on this errata.

5. IDCODE masks data from TDI input

The JTAG instruction IDCODE is not working correctly. Data to succeeding devices are replaced by all-ones during Update-DR.

Problem Fix / Workaround

- If ATmega128 is the only device in the scan chain, the problem is not visible.
- Select the Device ID Register of the ATmega128 by issuing the IDCODE instruction or by entering the Test-Logic-Reset state of the TAP controller to read out the contents of its Device ID Register and possibly data from succeeding devices of the scan chain. Issue the BYPASS instruction to the ATmega128 while reading the Device ID Registers of preceding devices of the boundary scan chain.
- If the Device IDs of all devices in the boundary scan chain must be captured simultaneously, the ATmega128 must be the first device in the chain.

6. Reading EEPROM by using ST or STS to set EERE bit triggers unexpected interrupt request.

Reading EEPROM by using the ST or STS command to set the EERE bit in the EECR register triggers an unexpected EEPROM interrupt request.

Problem Fix / Workaround

Always use OUT or SBI to set EERE in EECR.

Datasheet Revision History

Please note that the referring page numbers in this section are referred to this document. The referring revision in this section are referring to the document revision.

- Rev. 2467X-06/11**
1. Corrected typos in [“Ordering Information” on page 368](#).
- Rev. 2467W-05/11**
1. Added Atmel QTouch Library Support and QTouch Sensing Capability Features.
 2. Updated [“DC Characteristics” on page 318](#). R_{RST} maximum value changed from 60k Ω to 85k Ω .
 3. Updated [“Ordering Information” on page 368](#) to include Tape & Reel devices.
- Rev. 2467V-02/11**
1. Updated the literature number (2467) that accidentally changed in rev U.
 2. Editing update according to the Atmel new style guide. No more space between the numbers and their units.
 3. Reorganized the swapped chapters in rev U: 8-bit Timer/Counter 0, 16-bit TC1 and TC3, and 8-bit TC2 with PWM.
- Rev. 2467U-08/10**
1. Updated [“Ordering Information” on page 368](#). Added Ordering information for Appendix A ATmega128/L 105°C.
- Rev. 2467T-07/10**
1. Updated the [“USARTn Control and Status Register B – UCSRnB” on page 189](#).
 2. Added a link from [“Minimizing Power Consumption” on page 47](#) to [“System Clock and Clock Options” on page 35](#).
 3. Updated use of Technical Terminology in datasheet
 4. Corrected formula in [Table 133, “Two-wire Serial Bus Requirements,” on page 322](#)
 5. Note 6 and Note 7 below [Table 133, “Two-wire Serial Bus Requirements,” on page 322](#) have been removed
- Rev. 2467S-07/09**
1. Updated the [“Errata” on page 371](#).
 2. Updated the TOC with the newest template (version 5.10).
 3. Added note [“Not recommended from new designs“](#) from the front page.
 4. Added typical I_{CC} values for Active and Idle mode in [“DC Characteristics” on page 318](#).
- Rev. 2467R-06/08**
1. Removed [“Not recommended from new designs“](#) from the front page.

Rev. 2467Q-05/08

1. Updated **“Preventing EEPROM Corruption” on page 24.**
Removed sentence “If the detection level of the internal BOD does not match the needed detection level, and external low V_{CC} Reset Protection circuit can be used.”
2. Updated **Table 85 on page 196 in “Examples of Baud Rate Setting” on page 193.**
Removed examples of frequencies above 16MHz.
3. Updated **Figure 114 on page 238.**
Inductor value corrected from 10mH to 10 μ H.
4. Updated description of **“Version” on page 253.**
5. **ATmega128L removed from “DC Characteristics” on page 318.**
6. Added **“Speed Grades” on page 320.**
7. Updated **“Ordering Information” on page 368.**
Pb-Plated packages are no longer offered, and the ordering information for these packages are removed.
There will no longer exist separate ordering codes for commercial operation range, only industrial operation range.
8. Updated **“Errata” on page 371:**
Merged errata description for rev.F to rev.M in **“ATmega128 Rev. F to M”.**

Rev. 2467P-08/07

1. Updated **“Features” on page 1.**
2. Added **“Data Retention” on page 8.**
3. Updated **Table 60 on page 133 and Table 95 on page 235.**
4. Updated **“C Code Example(1)” on page 176.**
5. Updated **Figure 114 on page 238.**
6. Updated **“XTAL Divide Control Register – XDIV” on page 36.**
7. Updated **“Errata” on page 371.**
8. Updated **Table 34 on page 76.**
9. Updated **“Slave Mode” on page 166.**

Rev. 2467O-10/06

1. Added note to **“Timer/Counter Oscillator” on page 43.**
2. Updated **“Fast PWM Mode” on page 124.**
3. Updated **Table 52 on page 104, Table 54 on page 104, Table 59 on page 133, Table 61 on page 134, Table 64 on page 156, and Table 66 on page 157.**
4. Updated **“Errata” on page 371.**

- Rev. 2467N-03/06**
1. Updated note for [Figure 1 on page 2](#).
 2. Updated [“Alternate Functions of Port D” on page 77](#).
 3. Updated [“Alternate Functions of Port G” on page 84](#).
 4. Updated [“Phase Correct PWM Mode” on page 100](#).
 5. Updated [Table 59 on page 133](#), [Table 60 on page 133](#).
 6. Updated [“Bit 2 – TOV3: Timer/Counter3, Overflow Flag” on page 141](#).
 7. Updated [“Serial Peripheral Interface – SPI” on page 162](#).
 8. Updated Features in [“Analog to Digital Converter” on page 230](#)
 9. Added note in [“Input Channel and Gain Selections” on page 243](#).
 10. Updated [“Errata” on page 371](#).
- Rev. 2467M-11/04**
1. Removed “analog ground”, replaced by “ground”.
 2. Updated [Table 11 on page 40](#), [Table 114 on page 285](#), [Table 128 on page 303](#), and [Table 132 on page 321](#). Updated [Figure 114 on page 238](#).
 3. Added note to [“Port C \(PC7..PC0\)” on page 6](#).
 4. Updated [“Ordering Information” on page 368](#).
- Rev. 2467L-05/04**
1. Removed “Preliminary” and “TBD” from the datasheet, replaced occurrences of ICx with ICPx.
 2. Updated [Table 8 on page 38](#), [Table 19 on page 50](#), [Table 22 on page 56](#), [Table 96 on page 242](#), [Table 126 on page 299](#), [Table 128 on page 303](#), [Table 132 on page 321](#), and [Table 134 on page 323](#).
 3. Updated [“External Memory Interface” on page 25](#).
 4. Updated [“Device Identification Register” on page 253](#).
 5. Updated [“Electrical Characteristics” on page 318](#).
 6. Updated [“ADC Characteristics” on page 325](#).
 7. Updated [“Typical Characteristics” on page 333](#).
 8. Updated [“Ordering Information” on page 368](#).
- Rev. 2467K-03/04**
1. Updated [“Errata” on page 371](#).

- Rev. 2467J-12/03**
1. Updated [“Calibrated Internal RC Oscillator”](#) on page 41.
- Rev. 2467I-09/03**
1. Updated note in [“XTAL Divide Control Register – XDIV”](#) on page 36.
 2. Updated [“JTAG Interface and On-chip Debug System”](#) on page 48.
 3. Updated values for V_{BOT} (BODLEVEL = 1) in [Table 19](#) on page 50.
 4. Updated [“Test Access Port – TAP”](#) on page 246 regarding JTAGEN.
 5. Updated description for the JTD bit on [page 255](#).
 6. Added a note regarding JTAGEN fuse to [Table 118](#) on page 288.
 7. Updated R_{PU} values in [“DC Characteristics”](#) on page 318.
 8. Added a proposal for solving problems regarding the JTAG instruction IDCODE in [“Errata”](#) on page 371.
- Rev. 2467H-02/03**
1. Corrected the names of the two Prescaler bits in the SFIOR Register.
 2. Added Chip Erase as a first step under [“Programming the Flash”](#) on page 315 and [“Programming the EEPROM”](#) on page 316.
 3. Removed reference to the [“Multipurpose Oscillator”](#) application note and the [“32kHz Crystal Oscillator”](#) application note, which do not exist.
 4. Corrected OCn waveforms in [Figure 52](#) on page 125.
 5. Various minor Timer1 corrections.
 6. Added information about PWM symmetry for Timer0 and Timer2.
 7. Various minor TWI corrections.
 8. Added reference to [Table 124](#) on page 291 from both SPI Serial Programming and Self Programming to inform about the Flash Page size.
 9. Added note under [“Filling the Temporary Buffer \(Page Loading\)”](#) on page 280 about writing to the EEPROM during an SPM Page load.
 10. Removed ADHSM completely.
 11. Added section [“EEPROM Write During Power-down Sleep Mode”](#) on page 24.
 12. Updated drawings in [“Packaging Information”](#) on page 369.
- Rev. 2467G-09/02**
1. Changed the Endurance on the Flash to 10,000 Write/Erase Cycles.
- Rev. 2467F-09/02**
1. Added 64-pad QFN/MLF Package and updated [“Ordering Information”](#) on page 368.

2. Added the section [“Using all Locations of External Memory Smaller than 64 Kbyte” on page 32.](#)
3. Added the section [“Default Clock Source” on page 37.](#)
4. Renamed SPMCR to SPMCSR in entire document.
5. When using external clock there are some limitations regards to change of frequency. This is descried in [“External Clock” on page 42](#) and [Table 131, “External Clock Drive,” on page 320.](#)
6. Added a sub section regarding OCD-system and power consumption in the section [“Minimizing Power Consumption” on page 47.](#)
7. Corrected typo (WGM-bit setting) for:
 - [“Fast PWM Mode” on page 98](#) (Timer/Counter0).
 - [“Phase Correct PWM Mode” on page 100](#) (Timer/Counter0).
 - [“Fast PWM Mode” on page 151](#) (Timer/Counter2).
 - [“Phase Correct PWM Mode” on page 152](#) (Timer/Counter2).
8. Corrected [Table 81 on page 191](#) (USART).
9. Corrected [Table 102 on page 259](#) (Boundary-Scan)
10. Updated V_{il} parameter in [“DC Characteristics” on page 318.](#)

Rev. 2467E-04/02

1. Updated the Characterization Data in Section [“Typical Characteristics” on page 333.](#)
2. Updated the following tables:
 - [Table 19 on page 50](#), [Table 20 on page 54](#), [Table 68 on page 157](#), [Table 102 on page 259](#), and [Table 136 on page 328.](#)
3. Updated Description of OSCCAL Calibration Byte.

In the data sheet, it was not explained how to take advantage of the calibration bytes for 2MHz, 4MHz, and 8MHz Oscillator selections. This is now added in the following sections: Improved description of [“Oscillator Calibration Register – OSCCAL” on page 41](#) and [“Calibration Byte” on page 289.](#)

Rev. 2467D-03/02

1. Added more information about [“ATmega103 Compatibility Mode” on page 5.](#)
2. Updated [Table 2, “EEPROM Programming Time,” on page 22.](#)
3. Updated typical Start-up Time in [Table 7 on page 37](#), [Table 9](#) and [Table 10 on page 39](#), [Table 12 on page 40](#), [Table 14 on page 41](#), and [Table 16 on page 42.](#)
4. Updated [Table 22 on page 56](#) with typical WDT Time-out.
5. Corrected description of ADSC bit in [“ADC Control and Status Register A – ADCSRA” on page 244.](#)

6. Improved description on how to do a polarity check of the ADC differential results in [“ADC Conversion Result” on page 241.](#)
7. Corrected JTAG version numbers in [“JTAG Version Numbers” on page 256.](#)
8. Improved description of addressing during SPM (usage of RAMPZ) on [“Addressing the Flash During Self-Programming” on page 278,](#) [“Performing Page Erase by SPM” on page 280,](#) and [“Performing a Page Write” on page 280.](#)
9. Added note regarding OCDEN Fuse below [Table 118 on page 288.](#)
10. Updated Programming Figures:
[Figure 135 on page 290](#) and [Figure 144 on page 301](#) are updated to also reflect that AVCC must be connected during Programming mode. [Figure 139 on page 297](#) added to illustrate how to program the fuses.
11. Added a note regarding usage of the PROG_PAGELOAD and PROG_PAGEREAD instructions on [page 307.](#)
12. Added Calibrated RC Oscillator characterization curves in section [“Typical Characteristics” on page 333.](#)
13. Updated [“Two-wire Serial Interface”](#) section.
 More details regarding use of the TWI Power-down operation and using the TWI as master with low TWBRR values are added into the data sheet. Added the note at the end of the [“Bit Rate Generator Unit” on page 203.](#) Added the description at the end of [“Address Match Unit” on page 204.](#)
14. Added a note regarding usage of Timer/Counter0 combined with the clock. See [“XTAL Divide Control Register – XDIV” on page 36.](#)

Rev. 2467C-02/02

1. **Corrected Description of Alternate Functions of Port G**
 Corrected description of TOSC1 and TOSC2 in [“Alternate Functions of Port G” on page 84.](#)
2. **Added JTAG Version Numbers for rev. F and rev. G**
 Updated Table 100 on page 256.
3. **Added Some Preliminary Test Limits and Characterization Data**
 Removed some of the TBD's in the following tables and pages:
[Table 19 on page 50,](#) [Table 20 on page 54,](#) [“DC Characteristics” on page 318,](#) [Table 131 on page 320,](#) [Table 134 on page 323,](#) and [Table 136 on page 328.](#)
4. **Corrected [“Ordering Information” on page 368.](#)**
5. **Added some Characterization Data in Section [“Typical Characteristics” on page 333..](#)**
6. **Removed Alternative Algorithm for Leaving JTAG Programming Mode.**
 See [“Leaving Programming Mode” on page 315.](#)
7. **Added Description on How to Access the Extended Fuse Byte Through JTAG Programming Mode.**

See [“Programming the Fuses”](#) on page 317 and [“Reading the Fuses and Lock Bits”](#) on page 317.

Table of Contents***Features 1******Pin Configurations 2******Overview 2***

Block Diagram 3

ATmega103 and ATmega128 Compatibility 4

Pin Descriptions 5

Resources 8***Data Retention 8******About Code Examples 9******AVR CPU Core 10***

Introduction 10

Architectural Overview 10

ALU – Arithmetic Logic Unit 11

Status Register 11

General Purpose Register File 12

Stack Pointer 14

Instruction Execution Timing 14

Reset and Interrupt Handling 15

AVR ATmega128 Memories 18

In-System Reprogrammable Flash Program Memory 18

SRAM Data Memory 19

EEPROM Data Memory 21

I/O Memory 26

External Memory Interface 26

System Clock and Clock Options 36

Clock Systems and their Distribution 36

Clock Sources 37

Default Clock Source 38

Crystal Oscillator 39

Low-frequency Crystal Oscillator 40

External RC Oscillator 40

Calibrated Internal RC Oscillator 42

External Clock 43

Timer/Counter Oscillator 44

Power Management and Sleep Modes 45

Idle Mode 46

ADC Noise Reduction Mode 46

Power-down Mode 46
Power-save Mode 46
Standby Mode 47
Extended Standby Mode 47
Minimizing Power Consumption 48

System Control and Reset 50

Internal Voltage Reference 54
Watchdog Timer 55
Timed Sequences for Changing the Configuration of the Watchdog Timer 58

Interrupts 60

Interrupt Vectors in ATmega128 60

I/O Ports 66

Introduction 66
Ports as General Digital I/O 67
Alternate Port Functions 71
Register Description for I/O Ports 87

External Interrupts 90

8-bit Timer/Counter0 with PWM and Asynchronous Operation 93

Overview 93
Timer/Counter Clock Sources 94
Counter Unit 94
Output Compare Unit 95
Compare Match Output Unit 97
Modes of Operation 98
Timer/Counter Timing Diagrams 102
8-bit Timer/Counter Register Description 104
Asynchronous Operation of the Timer/Counter 107
Timer/Counter Prescaler 110

16-bit Timer/Counter (Timer/Counter1 and Timer/Counter3) 112

Overview 112
Accessing 16-bit Registers 115
Timer/Counter Clock Sources 118
Counter Unit 118
Input Capture Unit 119
Output Compare Units 121
Compare Match Output Unit 123
Modes of Operation 124
Timer/Counter Timing Diagrams 131
16-bit Timer/Counter Register Description 133

Timer/Counter3, Timer/Counter2, and Timer/Counter1 Prescalers
143***8-bit Timer/Counter2 with PWM*** 145

- Overview 145
- Timer/Counter Clock Sources 146
- Counter Unit 146
- Output Compare Unit 147
- Compare Match Output Unit 148
- Modes of Operation 149
- Timer/Counter Timing Diagrams 155
- 8-bit Timer/Counter Register Description 157

Output Compare Modulator (OCM1C2) 161

- Overview 161
- Description 161

Serial Peripheral Interface – SPI 163

- \overline{SS} Pin Functionality 167
- Data Modes 170

USART 171

- Overview 171
- Clock Generation 173
- Frame Formats 176
- USART Initialization 177
- Data Transmission – The USART Transmitter 178
- Data Reception – The USART Receiver 180
- Multi-processor Communication Mode 187
- USART Register Description 189
- Examples of Baud Rate Setting 194

Two-wire Serial Interface 198

- Features 198
- Two-wire Serial Interface Bus Definition 198
- Data Transfer and Frame Format 199
- Multi-master Bus Systems, Arbitration and Synchronization 201
- Overview of the TWI Module 204
- TWI Register Description 206
- Using the TWI 208
- Transmission Modes 213
- Multi-master Systems and Arbitration 225

Analog Comparator 227

- Analog Comparator Multiplexed Input 228

Analog to Digital Converter 230

- Features 230
- Operation 232
- Starting a Conversion 232
- Prescaling and Conversion Timing 233
- Changing Channel or Reference Selection 235
- ADC Noise Canceler 236
- ADC Conversion Result 241

JTAG Interface and On-chip Debug System 246

- Features 246
- Overview 246
- Test Access Port – TAP 246
- TAP Controller 248
- Using the Boundary-scan Chain 249
- Using the On-chip Debug System 249
- On-chip Debug Specific JTAG Instructions 250
- On-chip Debug Related Register in I/O Memory 251
- Using the JTAG Programming Capabilities 251
- Bibliography 251
- IEEE 1149.1 (JTAG) Boundary-scan 252
- Features 252
- System Overview 252
- Data Registers 252
- Boundary-scan Specific JTAG Instructions 254
- Boundary-scan Related Register in I/O Memory 255
- Boundary-scan Chain 255
- ATmega128 Boundary-scan Order 266
- Boundary-scan Description Language Files 272

Boot Loader Support – Read-While-Write Self-Programming 273

- Boot Loader Features 273
- Application and Boot Loader Flash Sections 273
- Read-While-Write and No Read-While-Write Flash Sections 273
- Boot Loader Lock Bits 275
- Entering the Boot Loader Program 276
- Addressing the Flash During Self-Programming 278
- Self-Programming the Flash 279

Memory Programming 286

- Program and Data Memory Lock Bits 286
- Fuse Bits 287
- Signature Bytes 289
- Calibration Byte 289
- Parallel Programming Parameters, Pin Mapping, and Commands 290
- Parallel Programming 292

Serial Downloading 300
SPI Serial Programming Pin Mapping 300
Programming Via the JTAG Interface 305

Electrical Characteristics 318

Absolute Maximum Ratings* 318
DC Characteristics 318
Speed Grades 320
External Clock Drive Waveforms 320
External Clock Drive 320
Two-wire Serial Interface Characteristics 322
SPI Timing Characteristics 323
ADC Characteristics 325
External Data Memory Timing 328

Typical Characteristics 333

Register Summary 362

Instruction Set Summary 365

Ordering Information 368

368

Packaging Information 369

64A 369
64M1 370

Errata 371

ATmega128 Rev. F to Q 371

Datasheet Revision History 373

Rev. 2467Q-03/08 373
Rev. 2467P-08/07 373
Rev. 2467O-10/06 374
Rev. 2467N-03/06 374
Rev. 2467M-11/04 374
Rev. 2467L-05/04 374
Rev. 2467K-03/04 375
Rev. 2467J-12/03 375
Rev. 2467I-09/03 375
Rev. 2467H-02/03 375
Rev. 2467G-09/02 376
Rev. 2467F-09/02 376
Rev. 2467E-04/02 376
Rev. 2467D-03/02 376

Rev. 2467C-02/02 377

Table of Contents i



Atmel Corporation

2325 Orchard Parkway
San Jose, CA 95131
USA

Tel: (+1)(408) 441-0311

Fax: (+1)(408) 487-2600

www.atmel.com

Atmel Asia Limited

Unit 1-5 & 16, 19/F
BEA Tower, Millennium City 5
418 Kwun Tong Road
Kwun Tong, Kowloon

HONG KONG

Tel: (+852) 2245-6100

Fax: (+852) 2722-1369

Atmel Munich GmbH

Business Campus
Parkring 4
D-85748 Garching b. Munich
GERMANY

Tel: (+49) 89-31970-0

Fax: (+49) 89-3194621

Atmel Japan

9F, Tonetsu Shinkawa Bldg.
1-24-8 Shinkawa
Chuo-ku, Tokyo 104-0033
JAPAN

Tel: (+81)(3) 3523-3551

Fax: (+81)(3) 3523-7581

© 2011 Atmel Corporation. All rights reserved.

Atmel®, Atmel logo and combinations thereof, AVR®, QTouch®, QMatrix®, AVR Studio® and others are registered trademarks or trademarks of Atmel Corporation or its subsidiaries. Windows® and others are registered trademarks of Microsoft Corporation in U.S. and other countries. Other terms and product names may be trademarks of others.

Disclaimer: The information in this document is provided in connection with Atmel products. No license, express or implied, by estoppel or otherwise, to any intellectual property right is granted by this document or in connection with the sale of Atmel products. **EXCEPT AS SET FORTH IN THE ATMEL TERMS AND CONDITIONS OF SALES LOCATED ON THE ATMEL WEBSITE, ATMEL ASSUMES NO LIABILITY WHATSOEVER AND DISCLAIMS ANY EXPRESS, IMPLIED OR STATUTORY WARRANTY RELATING TO ITS PRODUCTS INCLUDING, BUT NOT LIMITED TO, THE IMPLIED WARRANTY OF MERCHANTABILITY, FITNESS FOR A PARTICULAR PURPOSE, OR NON-INFRINGEMENT. IN NO EVENT SHALL ATMEL BE LIABLE FOR ANY DIRECT, INDIRECT, CONSEQUENTIAL, PUNITIVE, SPECIAL OR INCIDENTAL DAMAGES (INCLUDING, WITHOUT LIMITATION, DAMAGES FOR LOSS AND PROFITS, BUSINESS INTERRUPTION, OR LOSS OF INFORMATION) ARISING OUT OF THE USE OR INABILITY TO USE THIS DOCUMENT, EVEN IF ATMEL HAS BEEN ADVISED OF THE POSSIBILITY OF SUCH DAMAGES.** Atmel makes no representations or warranties with respect to the accuracy or completeness of the contents of this document and reserves the right to make changes to specifications and product descriptions at any time without notice. Atmel does not make any commitment to update the information contained herein. Unless specifically provided otherwise, Atmel products are not suitable for, and shall not be used in, automotive applications. Atmel products are not intended, authorized, or warranted for use as components in applications intended to support or sustain life.

Mouser Electronics

Authorized Distributor

Click to View Pricing, Inventory, Delivery & Lifecycle Information:

[Atmel:](#)

[ATMEGA128-16ANR](#) [ATMEGA128-16MN](#) [ATMEGA128-16MUR](#) [ATMEGA128L-8ANR](#) [ATMEGA128L-8MN](#)
[ATMEGA128L-8MUR](#) [ATmega128L-8MU](#) [ATmega128-16AU](#) [ATmega128-16MU](#)