

Schottky Diode

$$I_{FAV} = 2 \text{ A}$$

$$V_{RRM} = 60 \text{ V}$$

$$V_F = 0.75 \text{ V}$$

V_{RSM} V	V_{RRM} V	Type	Marking on product
60	60	DSS 2-60AT2	D2-60A
60	60	DSS 2-60AT2AP	D2-60A



Symbol	Conditions	Maximum Ratings	
I_{FRMS}		8	A
I_{FAV}	$T_C = 85^\circ\text{C}$; rectangular, $d = 0.5$	2	A
I_{FSM}	$T_{VJ} = 45^\circ\text{C}$; $t_p = 10 \text{ ms}$ (50 Hz), sine	10	A
$(dv/dt)_{cr}$		1000	V/ μs
T_{VJ}		-40...+175	$^\circ\text{C}$
T_{VJM}		175	$^\circ\text{C}$
T_{stg}		-40...+125	$^\circ\text{C}$
P_{tot}	$T_S = 25^\circ\text{C}$	1.8	W
Weight	typical	0.5	g

Symbol	Conditions ($T_J = 25^\circ\text{C}$ unless otherwise specified)	Characteristic Values		
		Typ.	Max.	
I_R ①	$V_R = V_{RRM}$ $V_R = V_{RRM}'$, $T_{VJ} = 125^\circ\text{C}$	2.5	1.0	mA mA
V_F ②	$I_F = 2 \text{ A}$; $T_{VJ} = 125^\circ\text{C}$ $I_F = 2 \text{ A}$	0.48	0.75	V V
R_{thJS}	Thermal resistance junction-to-PC board		80	K/W
C_T	$V_R = 25 \text{ V}$; $f = 1 \text{ MHz}$	190		pF

Pulse test: ① Pulse Width = 5 ms, Duty Cycle < 2.0 %
 ② Pulse Width = 300 μs , Duty Cycle < 2.0 %

Ordering Information

Part Number	Shipping Container	Quantity
DSS2-10AT2	Bulk	1,000
DSS 2-60AT2AP	Ammo Pack	2,000

TO-92 Package

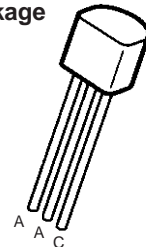

A = Anode C = Cathode

TO-92 Package Outline

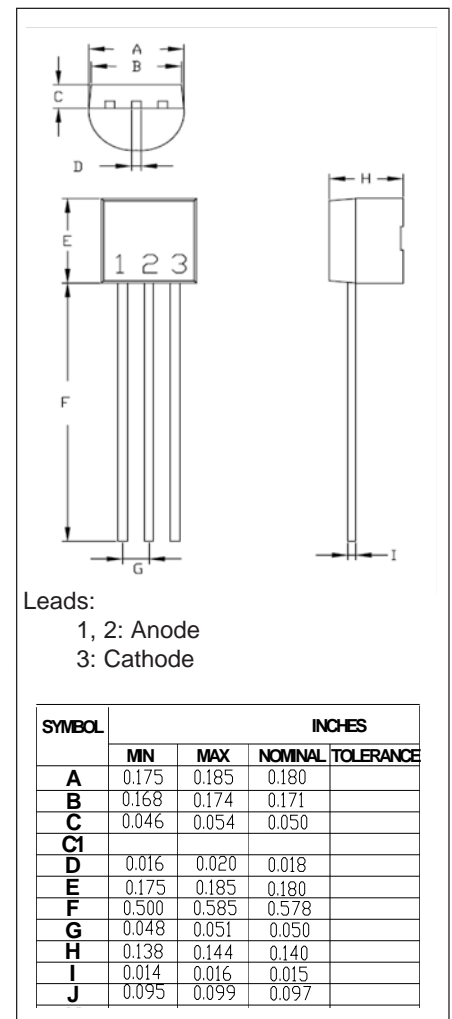

Fig. 1. Typical Forward Current vs. Forward Voltage

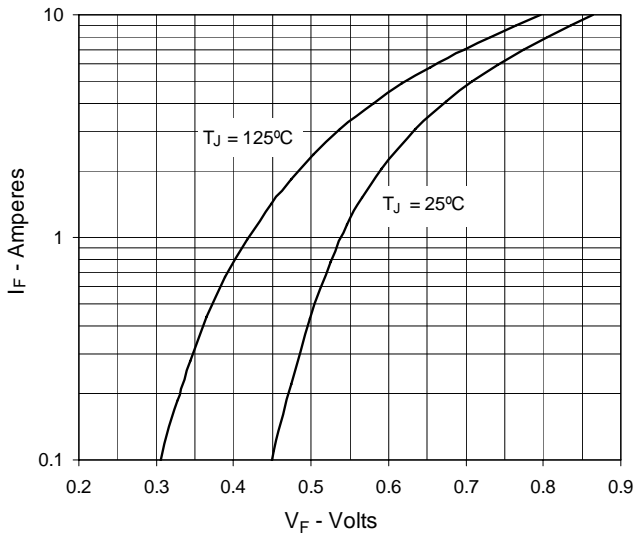

Fig. 2. Typical Reverse Current vs. Virtual Junction Temperature

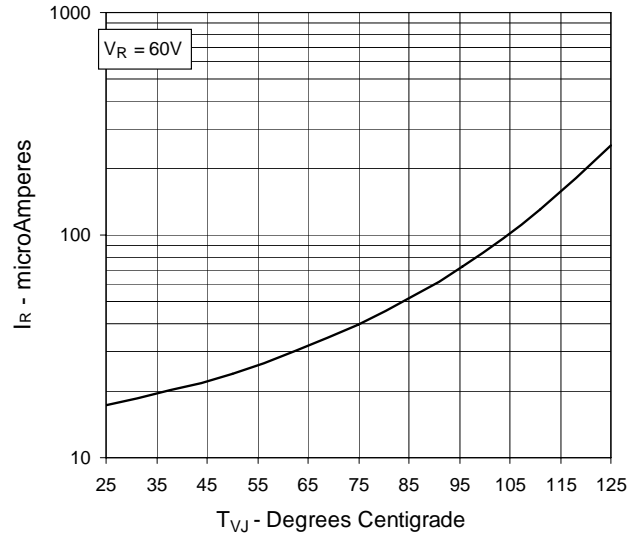

Fig. 3. Typical Junction Capacitance vs. Reverse Voltage

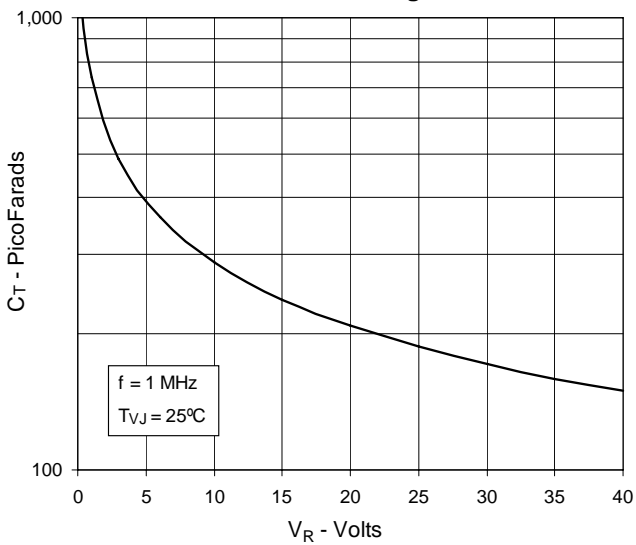
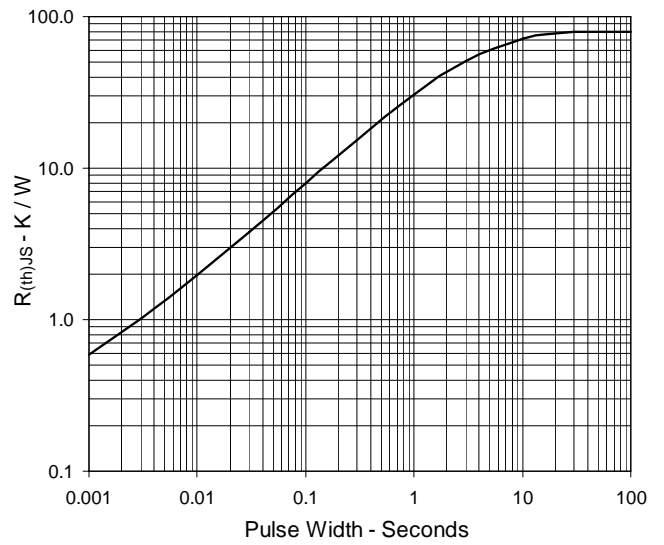

Fig. 4. Maximum Transient Thermal Resistance



Mouser Electronics

Authorized Distributor

Click to View Pricing, Inventory, Delivery & Lifecycle Information:

[IXYS:](#)

[DSS2-60AT2](#)